

**CITY OF TEMPE
DEVELOPMENT REVIEW COMMISSION**

**Meeting Date: 03/28/2023
Agenda Item: 5**

ACTION: Request a Use Permit to allow a massage establishment for THE RIVER MASSAGE, located at 1845 East Broadway Road, Suite No. 125 & 126. The applicant is The River Massage Inc.

FISCAL IMPACT: N/A

RECOMMENDATION: Staff – Approve, subject to conditions

BACKGROUND INFORMATION: THE RIVER MASSAGE (PL230043) is proposing to locate in suites 125 & 126 of an existing commercial center located on the southeast corner of McClintock Drive and Broadway Road. The use will be a massage establishment. The request includes the following:

ZUP230009 Use Permit to allow a massage establishment

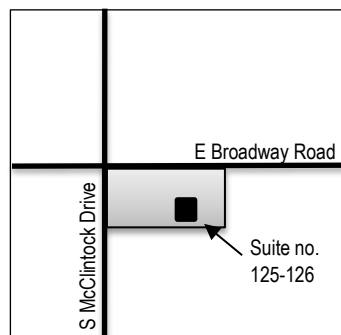

Property Owner	Red Mountain Asset Fund I, LLC
Applicant	Juntan Song, The River Massage Inc.
Zoning District	CSS, Commercial Shopping & Services
Site Area	127,250 s.f.
Building Area	36,432 s.f.
Suite Area	2,172 s.f.
Vehicle Parking	193 spaces total, 7 allocated for Suites 125 & 126 (7 min. required)
Hours of Operation	9:00 AM to 8:00 PM, Daily
Building Code Occupancy	B

ATTACHMENTS: Development Project File

STAFF CONTACT(S): Diana Kaminski, Senior Planner (480) 858-2391

Department Director: Jeff Tamulevich, Community Development Director

Legal review by: N/A

Prepared by: Diana Kaminski, Senior Planner

Reviewed by: Steve Abrahamson, Principal Planner

COMMENTS

The site is located on the southeast corner of McClintock Drive and Broadway Road and has never been platted. The site has condominiums to the south and apartments to the east, a gas station and large medical health center to the north, and industrial sites to the northeast. There are approximately five massage establishments located within a mile and one across the street from this location. The site contains restaurants, a smash room for rage release, a hookah bar, a veterinary hospital, a vocational school, and medical offices. The suite that the proposed use will be inhabiting is currently vacant and was formerly a salon equipment and beauty supply store.

PUBLIC INPUT

Neighborhood meeting not required. No calls of inquiry received upon completion of this report.

POLICE INPUT

A security plan is not required for the proposed use.

PROJECT ANALYSIS

GENERAL PLAN

According to the General Plan, the site is projected as a mixed-use land use with a residential density of up to 25 dwelling units per acre. The site is also located within an employment node. The proposed use helps facilitate the Economic Development Goals of the General Plan, namely, to sustain a business climate that fosters private business investment, to develop an increased tax base, and to promote a sustained improvement in the standard of living and quality of life for all residents.

ZONING

The site is zoned CSS, Commercial Shopping and Services, which requires a use permit to allow a massage establishment operation.

USE PERMIT

The proposed use requires a Use Permit to allow a massage establishment within the CSS, Commercial Shopping and Services zoning district. The applicant has provided a letter of explanation regarding the proposed operations and compliance with the criteria.

Section 6-308(E) Approval criteria for Use Permit (*in italics*):

1. *Any significant increase in vehicular or pedestrian traffic;* the 36,432 s.f. development provides 193 spaces to 29 tenant suites, some of which are combined uses. Suites 125 & 126 are 2,172 s.f. and are proposed to have 5 massage therapists. The proposed massage use is the same as the prior retail use for parking calculations and is allocated 7 spaces within the shared parking model. The use is proposed to be open from 9:00 AM to 8:00 PM daily and is not anticipated to generate traffic beyond the center's designed capacity.
2. *Nuisance arising from the emission of odor, dust, gas, noise, vibration, smoke, heat or glare at a level exceeding that of ambient conditions;* the proposed massage use is indoors and generally requires a quiet and meditative environment and is not expected to create any such nuisance. There will be no exterior renovations to the building, apart from signage, that would cause such a nuisance.
3. *Contribution to the deterioration of the neighborhood or to the downgrading of property values, which is in conflict with the goals, objectives or policies for rehabilitation, redevelopment or conservation as set forth in the city's adopted plans or General Plan;* the applicant is a Board Certified Therapist, and as such, the massage establishment is not expected to contribute to the deterioration of the neighborhood. There will be no exterior changes to the building apart from signage, and no expected downgrading of property values, as two suites within a commercial center that has had a third of its suites vacant at one time and that are currently vacant would be activated and would help revitalize the center.
4. *Compatibility with existing surrounding structures and uses;* existing uses in the commercial center include restaurants, a smash room for rage release, a hookah bar, a veterinary hospital, a vocational school, and medical offices. The previous use of suites 125 & 126 was a salon equipment and beauty supplies store. No changes to the exterior of the building are proposed other than signage, which is handled by a separate permit.

5. *Adequate control of disruptive behavior both inside and outside the premises which may create a nuisance to the surrounding area or general public; The massage establishment is not expected to create any disruptive behavior inside or outside the premises. The activation of the suite will provide additional surveillance to the area.*

REASONS FOR APPROVAL:

Based on the information provided by the applicant and the above analysis staff supports approval of the requested Use Permit. This request meets the required criteria and will conform to the conditions.

SHOULD AN AFFIRMATIVE ACTION BE TAKEN ON THIS REQUEST, THE FOLLOWING NUMBERED CONDITIONS OF APPROVAL SHALL APPLY, BUT MAY BE AMENDED BY THE DECISION-MAKING BODY.

CONDITIONS OF APPROVAL: (Non-standard conditions are identified in bold)

EACH NUMBERED ITEM IS A CONDITION OF APPROVAL. THE DECISION-MAKING BODY MAY MODIFY, DELETE OR ADD TO THESE CONDITIONS.

1. The Use Permit is valid only after a Building Permit has been obtained, the required inspections have been completed and a Final Inspection has been passed.
2. The Use Permit is valid for the plans as submitted within this application. Any additions or modifications may be submitted for review during the building plan check process.
3. Hours of operation to be from 9:00 AM to 8:00 PM daily.

CODE/ORDINANCE REQUIREMENTS:

THE BULLETED ITEMS REFER TO EXISTING CODE OR ORDINANCES THAT PLANNING STAFF OBSERVES ARE PERTINENT TO THIS CASE. THE BULLET ITEMS ARE INCLUDED TO ALERT THE DESIGN TEAM AND ASSIST IN OBTAINING A BUILDING PERMIT AND ARE NOT AN EXHAUSTIVE LIST.

USE PERMIT:

- The Use Permit is valid for THE RIVER MASSAGE and may be transferable to successors in interest through an administrative review with the Community Development Director, or designee.
- The use permit approval shall be void if the use is not commenced or if an application for a building permit has not been submitted, whichever is applicable, within twelve (12) months after the use permit is granted or within the time stipulated by the decision-making body.
- The decision-making body, upon finding that the applicant has not taken corrective actions to resolve issues related to the permit/approval and that a continuation of the permit/approval is not in the interest of the public health, safety and general welfare, can revoke the permit/approval after providing written notice of its intentions to the holder of the permit.
- Specific requirements of the **Zoning and Development Code (ZDC)** are not listed as a condition of approval but will apply to any application. To avoid unnecessary review time and reduce the potential for multiple plan check submittals, become familiar with the ZDC. Access the ZDC through <http://www.tempe.gov/zoning> or purchase from Development Services.
- All business signs shall receive a Sign Permit. Contact sign staff at 480-350-8435.
- Any intensification or expansion of use shall require a new Use Permit.
- All required permits and clearances shall be obtained from the Audit and Licensing Division of the City of Tempe prior to the Use Permit becoming effective.
- All required Federal, State, County, and Municipal permits, licenses, and clearances shall be obtained, or the Use Permit is void.

HISTORY & FACTS:

September 25, 1985 The Board of Adjustment approved a variance (A-85-9.15) for Broadway Square Shopping Center to reduce the overall required number of parking spaces from 216 to 201. A condition of approval was that a copy of the agreement granting the right to use the 54 parking spaces on the adjacent lot shall be filed with the Planning Staff prior to variance becoming effective.

February 14, 1986	Construction of Broadway Square Shopping Center passed final inspection.
November 29, 1989	The Board of Adjustment approved a parking use permit and wall variance for this site.
April 15, 2008	Hearing Officer approved a Use Permit for a Hookah Lounge/Tobacco Retailer at 1845 East Broadway Road Suite 9 in the CSS District.
April 6, 2010	Hearing Officer reviewed the conditions of approval of the use permit after determination by the City Attorney's office that condition four was not met.
September 29, 2010	After continuance from June 8 th and August 24 th , the Development Review Commission approved the requested appeal of the use permit revocation to allow the hookah lounge/tobacco retailer.
June 30, 2011	The Community Development Department staff administratively approved a shared parking analysis (PL110243) for the Broadway Square Plaza located at 1845 East Broadway Road in the CSS, Commercial Shopping and Services District. The peak demand for parking spaces for all uses is approximately 154 spaces, Monday through Friday. A minimum of 154 spaces must be maintained to support all uses.
September 13, 2012	The Community Development Department staff administratively approved a shared parking analysis (PL120294) for the Broadway Square Plaza located at 1845 East Broadway Road in the CSS, Commercial Shopping and Services District. The peak demand for parking spaces for all uses is 198 spaces, Monday through Friday. A minimum of 198 parking spaces must be maintained to support all uses.
December 5, 2013	Hearing Officer approved a Use Permit for the VCA Tri City Animal Hospital at 1845 East Broadway Road.
March 11, 2014	The Community Development Department staff administratively approved a shared parking analysis (PL140050) for the Broadway McClintock Shopping Center located at 1845 East Broadway Road in the CSS, Commercial Shopping and Services District. The peak demand for parking spaces for all uses is 198 spaces, Monday through Friday. A minimum of 198 parking spaces must be maintained to support all uses.
December 1, 2015	Hearing Officer approved the request by VCA TRI-CITY ANIMAL HOSPITAL (PL150446) located at 1845 East Broadway Road in the CSS, Commercial Shopping and Services District for a Use Permit to allow an outdoor dog walking area for an existing animal hospital.
May 18, 2016	Hearing Officer approved a Use Permit to allow a vocational school for VALLEY VOCATIONAL ACADEMY (PL160115) located at 1845 East Broadway Road, Suite 114 in the CSS, Commercial Shopping and Services District.
October 19, 2016	The Community Development Department Planning Division Staff administratively approved a Shared Parking Analysis for Broadway Square Shopping Center (PL160115) located at 1845 East Broadway Road in the CSS, Commercial Shopping and Services District. The peak demand for parking spaces for all uses is 192 spaces, Monday through Friday during the 1pm hour; and 115 spaces, Saturday and Sunday during the 5pm hour. A minimum of 192 off-street parking spaces must be maintained; 198 spaces are provided.
September 25, 2019	Development Review Commission approved a Use Permit to allow a tobacco retailer in the CSS, Commercial Shopping and Service district, for VIRTUE VAPE, located at 1845 East Broadway Road.

- May 23, 2022 Community Development Department Planning Division staff administratively approved an updated parking analysis for BROADWAY AND MCCLINTOCK COMMERCIAL CENTER located at 1845 East Broadway Road in the CSS zoning district. The site required 344 spaces and provided 193 with shared parking between uses at different times of day.
- May 24, 2022 Development Review Commission approved a Use Permit to allow a bar for CATALYST CRAFTED ALES, including a brewery with taproom, located at 1845 East Broadway Road, Suite 106.

ZONING AND DEVELOPMENT CODE REFERENCE:

[Section 3-202, Permitted Uses in Commercial and Mixed-Use Districts](#)

[Section 6-308, Use Permit](#)

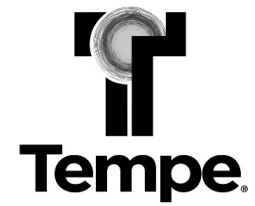

DEVELOPMENT PROJECT FILE

for

**THE RIVER MESSAGE
(PL230043)**

ATTACHMENTS:

- 1-9. Site Context (Location Map, Aerial and Site Context Photos)
- 10-11. Applicant's Letter of Explanation
- 12-14. Site Design (Site Plan, Existing and Proposed Floor Plans)



Tempe

PL230043

THE RIVER MASSAGE



Aerial Map

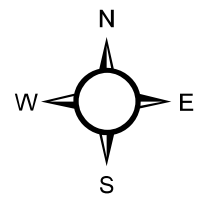

THE RIVER MASSAGE

PL230043

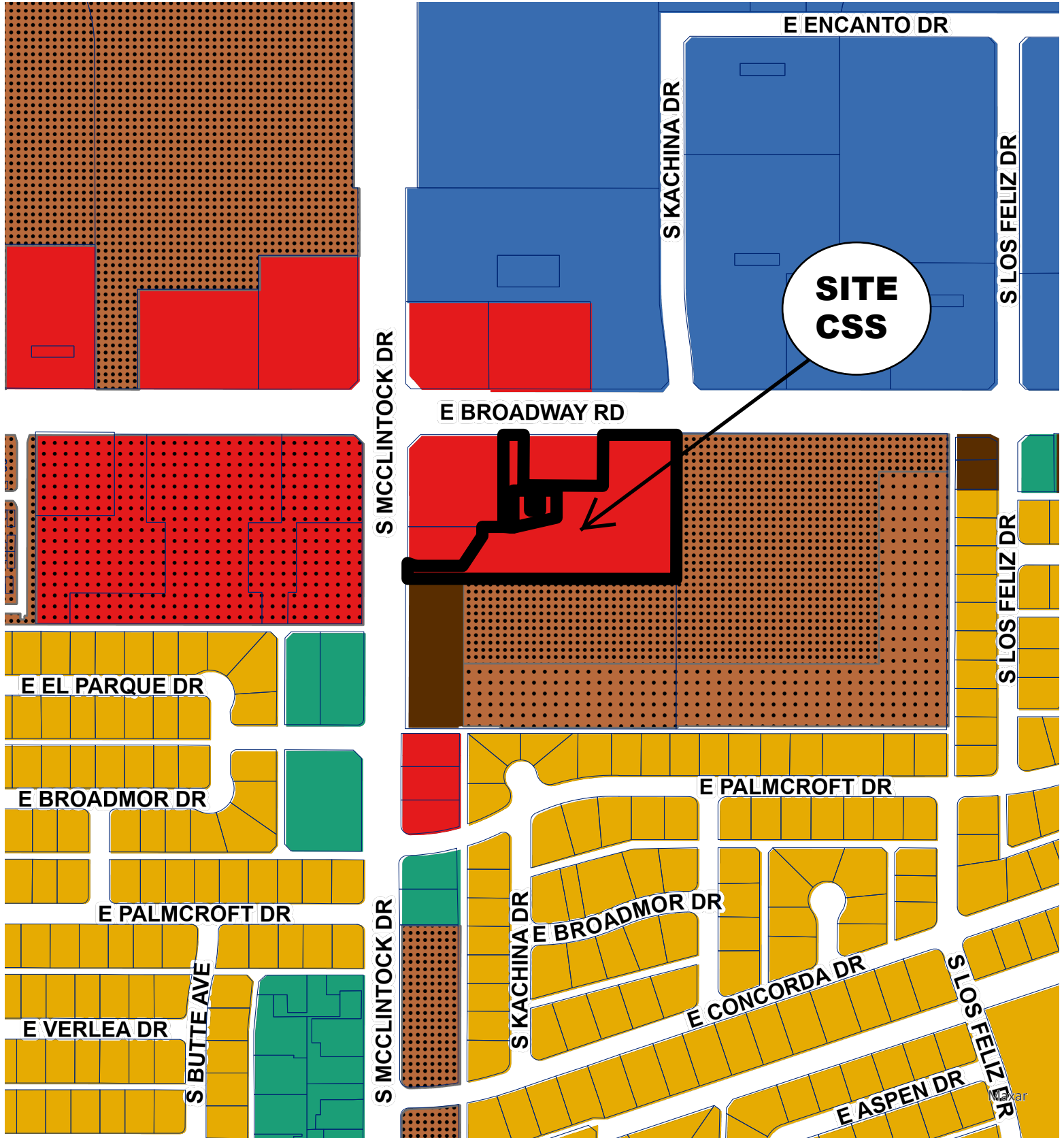

- General Industrial District (GID)
- Commercial Shopping and Services (CSS)
- Planned Commercial Center Neighborhood (PCC-1)
- Residential/Office (RO)
- Single-Family Residential (R1-6)
- Multi-Family Residential Restricted (R-3R)
- Multi-Family Residential Limited (R-3)

- Multi-Family Residential General (R-4)
- Parcels
- Twelve Point**
- CenterlineSubType**
- ADOT
- Canal

- Monument
- Private
- Railroad
- Street
- <all other values>

ATTACHMENT 2

Zoning District

- Light Industrial District (LID)



The River Massage Context Photos
1845 E. Broadway Rd. Suite 125-126, Tempe, AZ 85213

Arial View of Plaza	Pg. 2
Front View of Suite 125-126	P.g 3
North View	Pg. 4
East View	Pg. 5
South View	Pg. 6
West View	Pg. 7

Aerial View of Plaza



Front View of Suite 125-126



North View



East View



South View



West View



Letter of Explanation – The River Massage
1845 E. Broadway Rd. Suite 125-126, Tempe, AZ 85282

I am writing to request the approval of the Use Permit application to open a massage establishment at 1845 E. Broadway Rd. Suite 125-126, Tempe, AZ 85282.

At this establishment, we will be offering massage therapy. Our intended operation business hours are Monday to Saturday from 9:00 AM to 8:00 PM and closed on Sundays and all National Holidays. We aim to have about five full-time employees (massage therapists), two front desk assistants, and two managers. They will work as employees in the establishment, offering more job opportunities for the community.

The overall commercial property is 36,432 sq ft, suite 125-126 of the proposed establishment is 2,172 sq ft. We plan to divide it into six single treatment rooms and two couple's rooms (for group of two clients). There are also extra rooms for client interchanges and turnovers, as some senior clients may require more time for checkout. In addition, there are 193 parking spaces on site shared through existing shared parking model with seven spaces available for our suites.

We believe that our massage business will be an excellent addition to the community, as it will offer a very effective self-care method for the public. Our goal for opening the business is to create a peaceful and rejuvenating environment where people can get away and relax for a limited time. We strive to offer high-quality massages that benefit the health and well-being of the community.

We will follow the city's zoning and development code criteria as follows,

- a. Vehicular/pedestrian traffic in adjacent areas: Our business will not heavily impact significant vehicular/pedestrian traffic in the adjacent areas. Massage therapists do not have a set work time. Some will be available only in the morning, and some will be available only on weekdays. With the limited number of employees and schedules available, we will have a maximum of five clients per hour. Since clients might carpool for a couple's appointment, the number of cars might also be reduced.
- b. Ambient conditions: Regarding environment conditions, our business will be conducted in a manner that is considerate of our neighbors and surrounding businesses. We will not produce any additional noise or pungent odors as we are a place for peace and relaxation. Clients will be treated in individual rooms, and peaceful music will be played inside. Since smell could trigger allergic responses in clients, we only use fragrance-free mediums.
- c. Deterioration of the neighborhood/downgrading of property values: Our business will not contribute to the deterioration of the neighborhood or the fall of surrounding property values. Massage therapy is seen as a non-invasive alternative medicine, so many doctors

- and nurses refer their own clients to receive massage therapy. Since it is a sought after service and backed by medical professionals, it is a desirable asset to the neighborhood.
- d. Compatibility with existing surrounding structures and uses: Other than the existing restaurants, smash room for rage release, brewery house, and medical offices, massage therapy can offer a diverse stress release choice to the customers. Massage therapy is a non-invasive alternative medicine proven to be beneficial to both physical and mental health. In addition, it complements the healthcare providers in the same plaza and the health center across the street.
 - e. Disruptive behavior: Massage therapy is a source of quiet enjoyment. In such relaxed environments, conflicts or disruptive behavior rarely arise. If we encounter such a situation, we will compensate the client and kindly ask them to leave the premise.

The owner Juntan Song is experienced with massage therapy both as a practitioner and a consumer. Her family has owned and operated two massage establishments in Albuquerque, New Mexico, for over ten years. She has been in the industry for four years as a manager of a massage establishment and is currently a licensed massage therapist (MT 28960) in Arizona. She is also a National Board-Certified Massage Therapist (BCTMB 2000846) and an exam writer for the Federation of State Massage Therapy Boards (the standardized MBLEx exam).

Thank you for your time and consideration.

Best regards,



Juntan Song

Owner

juntan.song@hotmail.com

626-757-6278

A TENANT IMPROVEMENT FOR:

The River Message

Building Suite 125-126

1845 East Broadway Road

GENERAL NOTES

- These drawings are based on landlord provided shell plan. Field verify all dimensions and any discrepancies that arise because of any deviations in actual conditions from existing plans, must be coordinated by contractor with this drawing, contractor to inform ARCHITECT if conditions represented in this drawing differ from any in place construction before proceeding with the work.
- Every effort has been made to make a complete and accurate presentation of the work required for this addition. Due to the nature of remodeling projects, and because the existing plans may not accurately reflect in place construction, not every condition can be addressed. Contractor to obtain a building permit for any new work beyond the scope of these drawings that is required during construction, before the new work is begun.
- Verify all dimensions and conditions in field prior to construction and inform ARCHITECT of any discrepancy between the various drawings and with in place construction.
- Contractor to coordinate any required installation of Tenant supplied new equipment with tenant's fixture supplier and installation to be in accordance with manufacturer's and tenant's instructions, at indicated locations. Contractor to coordinate ARCHITECT, mechanical and electrical drawings with any equipment requirements. Any discrepancies shall be brought to the attention of ARCHITECT before proceeding with work.
- Do not separate individual sheets from complete sets of drawings. Only the most current revised sets of drawings shall be at job site. The ARCHITECT is not responsible for problems arising because of the use of outdated or superseded sets of construction drawings. Do not scale drawings. Written dimension takes precedence over actual scaled measurement.
- All designs, drawings, and details represent completed in place work. ARCHITECT shall have no control or charge of and shall not be responsible for construction means, methods, techniques, sequences, or procedures or for safety precautions and programs in connection with the work, for the acts or omissions of the Contractor, Subcontractor or any other person performing any other portion of the work or the failure of any of them to carry out the work in conformance with the contract documents, or instructions by the tenant.
- Provide adequate concealed blocking and anchoring for ceiling and wall mounted equipment and accessories.
- When any material, equipment, mechanical and electrical system is noted, all parts and materials required to complete the system shall be furnished and installed per the manufacturer's instructions.
- Unless otherwise noted, electrical conduits, plumbing lines, etc. shall be concealed and framing shall be of adequate size to accomplish this without variations in the wall plane.
- Coordinate with all trades the need for sleeves, block outs, structural support, or other preset accessories.
- It is the intent of these drawings to define a complete, finished job. Any discrepancy or omission which would normally be required to complete the work or anything required by City field inspector, shall be provided and finished as if specifically noted at no additional cost. Unless a written change order is signed by the tenant prior to start of additional work.
- No attempt has been made in these plans to define or separate areas of responsibility between General Contractor, decor supplier or Tenant. It is the responsibility of these parties to coordinate their respective portions of the work with the other to avoid duplications, scheduling problems, and omissions.
- Bidders are expected to visit the site to form their own conclusions as to the character of the work and report any inconsistencies to the ARCHITECT before the bid.
- All work is to be done in accordance with all applicable codes and ordinances.
- Perform the removal, cutting, drilling, etc., of existing work with extreme care, and using small tools in order not to jeopardize the structural integrity of the building. Cutting of existing concrete and masonry with saws and core drills.
- Patch, repair, cap off and adapt as necessary, all mechanical, plumbing, and electrical systems required to be altered due to the execution of the new work.
- Unless specifically scheduled for reuse by the Tenant, all demolished materials shall become the property of the contractor, and shall be removed from the site.
- Carefully remove all materials that are scheduled for reuse by the Owner, and protect same.
- Debris from demolition shall not be allowed to accumulate within the building or on the site.
- Provide protection from the weather where openings in the existing roof are cut for new work. After work is complete, repair any damage to the roof and maintain all new penetrations in a weather tight condition. No new roof penetrations are allowed unless specifically approved in writing by mail owner, prior to execution of the work, in order to maintain roofing warranty. Penetrations if any shall be made by Owner's roofing contractor. It is the responsibility of the Contractor to provide a weather tight watertight building.
- All exposed utility systems, conduit, duct work, wire molding, piping, etc., to be installed in a neat, orderly manner for a finished appearance, and painted to match adjacent surfaces.
- Safety shore existing construction whenever existing supports are removed to allow the installation of new work.
- Rebuild any existing work which has to be removed to allow the installation of new work as required by the ARCHITECT or decor supplier.
- Colors, finishes etc. shall be selected by Tenant. Decor to be selected by Tenant installed by contractor.
- Report any building deficiency or unsafe condition of any kind to ARCHITECT and Tenant.
- ARCHITECT cannot and does not warrant the safety or integrity of the existing building or any of its components or that the original tenant improvement was constructed to code. The ARCHITECT's involvement with the existing building is solely limited to the new work shown in the ARCHITECT drawings.
- Install hand held fire extinguishers in size type and location as required by local Fire Marshall.
- Contractor to maintain proper lighting ventilation and sanitation at all times during construction.
- Do not cover work until approved by City building inspector.
- CONTRACTOR is to verify if existing concrete slab is a post tensioned slab. If slab is post tension CONTRACTOR is to verify location of tension rod, and to consult with a structural engineer.

PROJECT DATA

CODE:

BUILDING CODE	2018 INTERNATIONAL BUILDING CODE
MECHANICAL CODE	2018 INTERNATIONAL MECHANICAL CODE
PLUMBING CODE	2018 INTERNATIONAL PLUMBING CODE
ELECTRICAL CODE	2018 INTERNATIONAL FIRE CODE
FIRE CODE	2018 INTERNATIONAL FIRE CODE
ENERGY	2018 INTERNATIONAL ENERGY CONSERVATION CODE

OTHER STATUTES, ORDINANCES, LAWS, REGULATIONS, RULES, ORDERS, AND CODES SPECIFIED IN OTHER SECTIONS OF THE SPECIFICATIONS OR BEARING ON THE WORK INCLUDING REGULATIONS OF OCCUPATIONAL SAFETY AND HEALTH UNLESS SUPERSEDED BY STATE STATUTE OR LAW.

BUILDING CONSTRUCTION TYPE

EXISTING BUILDING TYPE VB - STEEL FRAME CONSTRUCTION

FIRE SPRINKLER / ALARM NOTE

FIRE SPRINKLER EXISTING- LESS THAN 10' HEADS TO BE ADJUSTED

CONSULTANTS

MARK LEWIS
INSIGHTDESIGN LLC
P.O. BOX 1392
GLENDALE, AZ 85318
CONTACT: MARK LEWIS 623-341-6514
BILL SCHROEDER
ARCHITECTURAL CONCEPTS, INC. (ASSOCIATE ARCHITECT (IND))
FOUNTAIN HILLS, ARIZONA 85268

DALE HAYES ENGINEERING LLC
24820 NORTH 16TH AVE, SUITE 107
PHOENIX, ARIZONA
CONTACT DALE HAYES 1-602-617-9992

SCOPE OF WORK

EXISTING SUITE CURRENTLY VACANT SPACE WILL BECOME A MESSAGE B OCCUPANCY

- MINOR DEMO AND PATCH
- EXISTING RESORT TO REMAIN
- ADD A FEW OF PARTITION WALLS

SINGLE

STOREFRONT SIGN AGE TO BE SUBMITTED UNDER SEPARATE PACKAGE FOR LL REVIEW

SHEET INDEX

A-1	COVER SHEET	SITE PLAN (FOR REFERENCE ONLY)
A-2	EXISTING/ DEMO FLOOR PLAN AND NOTES	
A-3	NEW FLOOR PLAN AND NOTES	
A-4	REFLECTED CEILING PLAN & DETAILS	
M1	MECHANICAL	
P1	PLUMBING	
E1	ELECTRICAL	
E2	ELECTRICAL	
E3	ELECTRICAL	

TENANT

LOCATION AND TENANT INFORMATION:

THE RIVER MESSAGE, INC.
CONTACT CHAD TAINRICK 1 602 310 4318
1845 EAST BROADWAY BLVD
SUITE 125 AND 126
TEMPE, ARIZONA

OWNER INFORMATION:

RED MOUNTAIN ASSET FUND I LLC
1234 EAST 17TH STREET
SANTA ANA, CA, USA, 92701
NAI HORIZON
CONTACT NORTH HONG
1-602-353-2682
2944 - NORTH 44ST
SUITE 200
PHOENIX, ARIZONA 85018

OCCUPANT CLASSIFICATION

CLASSIFICATION _____ B

SQUARE FOOTAGE

OFFICE AREA	1800 SF.	/ 100 =	18
	150 SF.	/ 100 =	2
STORAGE	150 SF.	/ 200 =	1
RESTROOM	150 SF.	0 =	0
TOTAL			20

OCCUPANT CLASSIFICATION

CLASSIFICATION _____ B

OCCUPANT LOAD

NOTE POSTING OCCUPANT LOAD. EVERY ROOM OR SPACE THAT IS ASSEMBLY OCCUPANT LOAD OF THE ROOM OR SPACE POSTED IN A CONSPICUOUS PLACE, NEAR THE MAIN EXIT OR EXIT ACCESS DOORWAY FROM THE ROOM OR SPACE. POSTED SIGNS SHALL BE OF AN APPROVED LEGIBLE PERMANENT DESIGN AND SHALL BE MAINTAINED BY THE OWNER OR AUTHORIZED AGENT

ONE (1) EXITS REQUIRED, ONE (1) EXITS PROVIDED
FIRE EXTINGUISH REQUIRED (REFER TO PLAN)

CONSTRUCTION TYPE:

CLASSIFICATION _____ B

EXITS

1 EXITS REQUIRED
1 EXIT PROVIDED

REST ROOM

REST ROOM MEETS ADA ACCESSIBLE.

PARKING

EXISTING PARKING PROVIDED TOTAL 193 - 1 SHARED SPACES FOR THIS SUITE



Message JT Site Plan

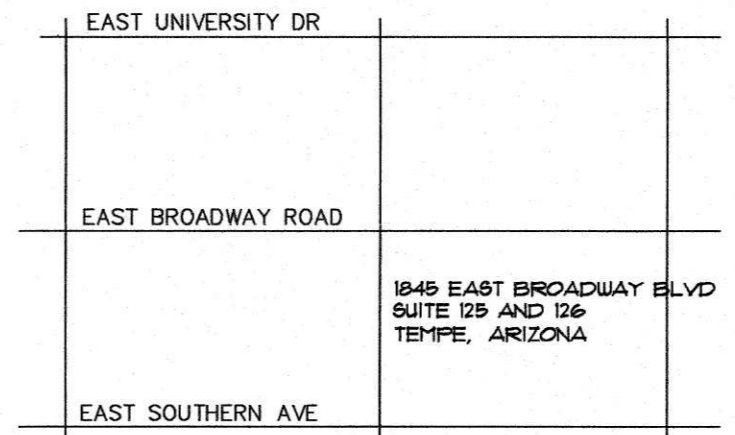
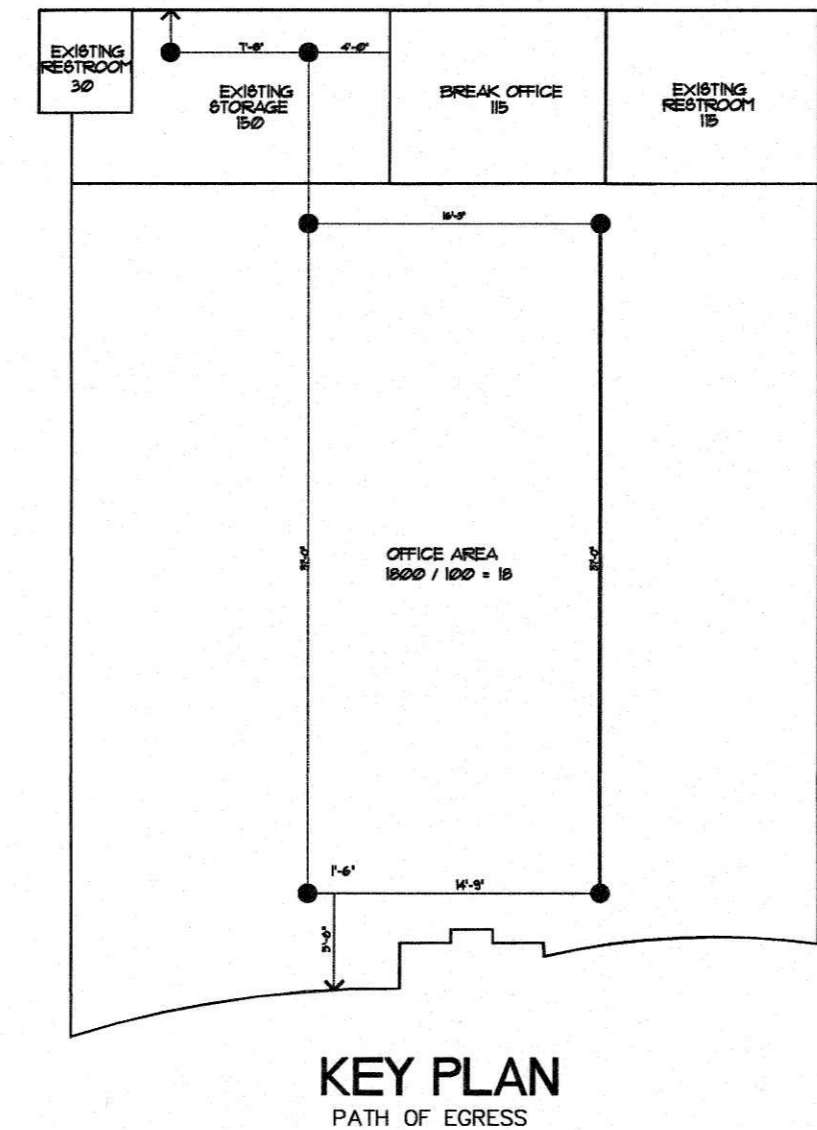

VICINITY MAP

PROJECT LOCATION

1845 EAST BROADWAY BLVD
SUITE 125 AND 126
TEMPE, ARIZONA

NOTICE

THE CONTRACTOR SHALL INSPECT ALL EXISTING CONDITIONS AND AREAS TO BE MODIFIED TO VERIFY THE CONDITIONS MATCH THE CONSTRUCTION DOCUMENTS PRIOR TO STARTING ANY WORK. IF CONDITIONS ARE DIFFERENT THEN SHOWN, THE CONTRACTOR SHALL NOTIFY DESIGNER OF RECORD OF THE ACTUAL CONDITION. THE CONTRACTOR SHALL NOT PROCEED PRIOR TO NOTIFICATION FROM THE DESIGNER OF RECORD AND RECEIVING INSTRUCTIONS OR DRAWINGS THAT MAY BE REQUIRED.

REVISION DATE: INITIAL:

1.

2.

STAMP:

EXP. DATE 12 / 31 / 2023

INSIGHTDESIGN LLC
GLENDALE, AZ 85318
CONTACT: MARK LEWIS 623-341-6514
ARCHITECTURAL CONCEPTS, INC. (ASSOCIATE ARCHITECT (IND))
FOUNTAIN HILLS, ARIZONA 85268



The River Message
1845 East Broadway
Suite 125 - 126
Tempe, Arizona
Contact: JT Song

COVER SHEET

DRAWN BY: _____

CHECK BY: _____

DATE: _____

JOB No: _____

SHEET CONTENTS: _____

SHEET No: _____

A-1

OF SHEETS

INSIGHTDESIGN LLC
 GLENDALE, AZ 85318
 CONTACT: MARK LEWIS 623-341-6514
 ARCHITECTURAL CONCEPTS, INC. (ASSOCIATE ARCHITECT (IND))
 FOUNTAIN HILLS, ARIZONA 85268

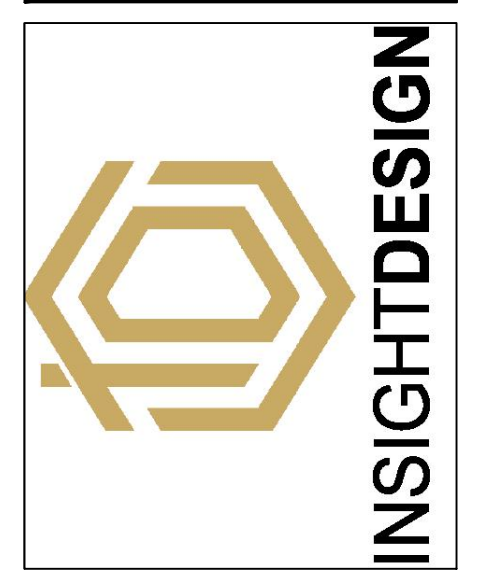

The River Message
 1845 East Broadway
 Suite 125 - 126
 Tempe, Arizona
 Contact: JT Song
DEMO / FLOOR PLAN

DRAIN BY: _____
 CHECK BY: _____
 DATE: _____
 JOB No.: _____
 SHEET CONTENTS:

SHEET No.:
A2
 OF SHEETS

DEMOLITION NOTES:

1. THE WORK MAY INCLUDE DEMOLITION OF EXISTING CONSTRUCTION, REMOVAL OF VARIOUS ITEMS OF EQUIPMENT AND CONSTRUCTION, AND THE CUTTING OR ALTERATION OF EXISTING CONSTRUCTION AS SHOWN, NOTED OR IMPLIED ON THE DRAWINGS. CONTRACTOR SHALL DETERMINE AND INVENTORY ALL NECESSARY DEMOLITION AND ALTERATION OF ITEMS TO PROVIDE FOR A COMPLETE INSTALLATION OF NEW WORK. ALL COSTS OF REMOVAL, REPAIR OR REPLACEMENT SHALL BE INCLUDED IN THE BID. ADDITIONAL COSTS FOR DEMOLITION OF ITEMS HIDDEN OR INACCESSIBLE DURING THE BIDDING PHASE, SHALL BE SUBMITTED FOR APPROVAL PRIOR TO BEGINNING THE WORK.
2. AT ALTERED CONSTRUCTION, REPAIR CUT EDGES, REPLACE CONSTRUCTION, AND FIT NEW TO EXISTING CONSTRUCTION TO MATCH EXISTING WORK. MAKE JOINTS OF NEW AND EXISTING PATCHES VERY SMOOTH, EVEN AND PRACTICALLY INVISIBLE. COORDINATE ALL REPLACEMENT AND REPAIR REQUIREMENTS WITH LANDLORD CONSTRUCTION CRITERIA AND TENANT COORDINATOR.
3. SAW-CUT CONCRETE WITH DIAMOND SAW. JACKHAMMERING WILL NOT BE PERMITTED EXCEPT WITH THE EXPRESSED WRITTEN APPROVAL OF THE LANDLORD. CUT IN ACCURATELY LOCATED, STRAIGHT LINES, AND BREAK OUT SECTIONS. FLOOR MAY BE CORE DRILLED WHERE APPROPRIATE FOR INSTALLATION OF PIPES AND SIMILAR ITEMS. COORDINATE ALL CORE LOCATIONS AND SLAB MODIFICATIONS WITH LANDLORD STRUCTURAL ENGINEER. WHERE EXISTING PIPING AND OTHER SIMILAR ITEMS ARE UNDER EXISTING SLABS, EXERCISE CARE TO PROTECT FROM DAMAGE. EXERCISE CARE WHEN CUTTING ADJACENT TO EXISTING WALLS TO AVOID DAMAGE TO WALLS. IF DAMAGED, REPAIR AS REQUIRED TO ORIGINAL CONDITION.
4. DOORS & FRAMES: IF DOORS AND FRAMES ARE TO BE REUSED ON THE WORK, CAREFULLY REMOVE DOOR FROM FRAMES AND REMOVE FRAMES FROM OPENING, TAKING CARE TO AVOID DAMAGE. REMOVE HARDWARE, CLEAN, REFURBISH, AND STORE FOR REINSTALLATION WHERE INDICATED. FOR DOORS AND FRAMES TO BE SALVAGED, CAREFULLY REMOVE FROM OPENING AND DELIVER FOR STORAGE WHERE INDICATED.
5. PREVENT MOVEMENT OR SETTLEMENT OF STRUCTURE. PROVIDE AND PLACE BRACING AND SHORING AND BE RESPONSIBLE FOR SAFETY AND SUPPORT OF STRUCTURE, AS DETERMINED BY G.C. ENLISTED STRUCTURAL ENGINEER. ASSUME LIABILITY FOR SUCH MOVEMENT, SETTLEMENT, DAMAGE OR INJURY.
6. ARRANGE AND PAY FOR DISCONNECTING, REMOVING AND CAPPING UTILITY SERVICES WITHIN AREAS AFFECTED BY DEMOLITION. PLACE MARKERS TO INDICATE LOCATION OF DISCONNECTED SERVICES. LOCATE SPRINKLER SHUT-OFF VALVE AND SMOKE ALARM PRIOR TO COMMENCING WORK. COORDINATE REQUIRED MODIFICATION WITH LANDLORD.
7. CAREFULLY REMOVE MATERIALS AND EQUIPMENT WHICH ARE INTENDED TO BE REUSED. STORE IN A SECURE LOCATION. REMOVE DEBRIS, REFUSE AND MATERIALS BEING DEMOLISHED IMMEDIATELY FROM THE SITE.
8. ERECT AND MAINTAIN WEATHERPROOF AND DUSTPROOF CLOSURES AND PARTITIONS TO PREVENT WEATHER DAMAGE OR SPREAD OF DUST, FUMES AND SMOKE TO OTHER PARTS OF THE BUILDING, IN ACCORDANCE WITH OWNER GUIDELINES AND STIPULATIONS.
9. PERFORM DEMOLITION IN ACCORDANCE WITH APPLICABLE AUTHORITIES HAVING JURISDICTION.
10. REPAIR ALL DEMOLITION IN EXCESS OF THAT REQUIRED AT NO COST TO THE OWNER.
11. REMOVE FROM SITE CONTAMINATED, VERMIN INFESTED OR DANGEROUS MATERIALS ENCOUNTERED: DISPOSE OF BY SAFE MEANS TO PROTECT HEALTH OF WORKERS AND PUBLIC.

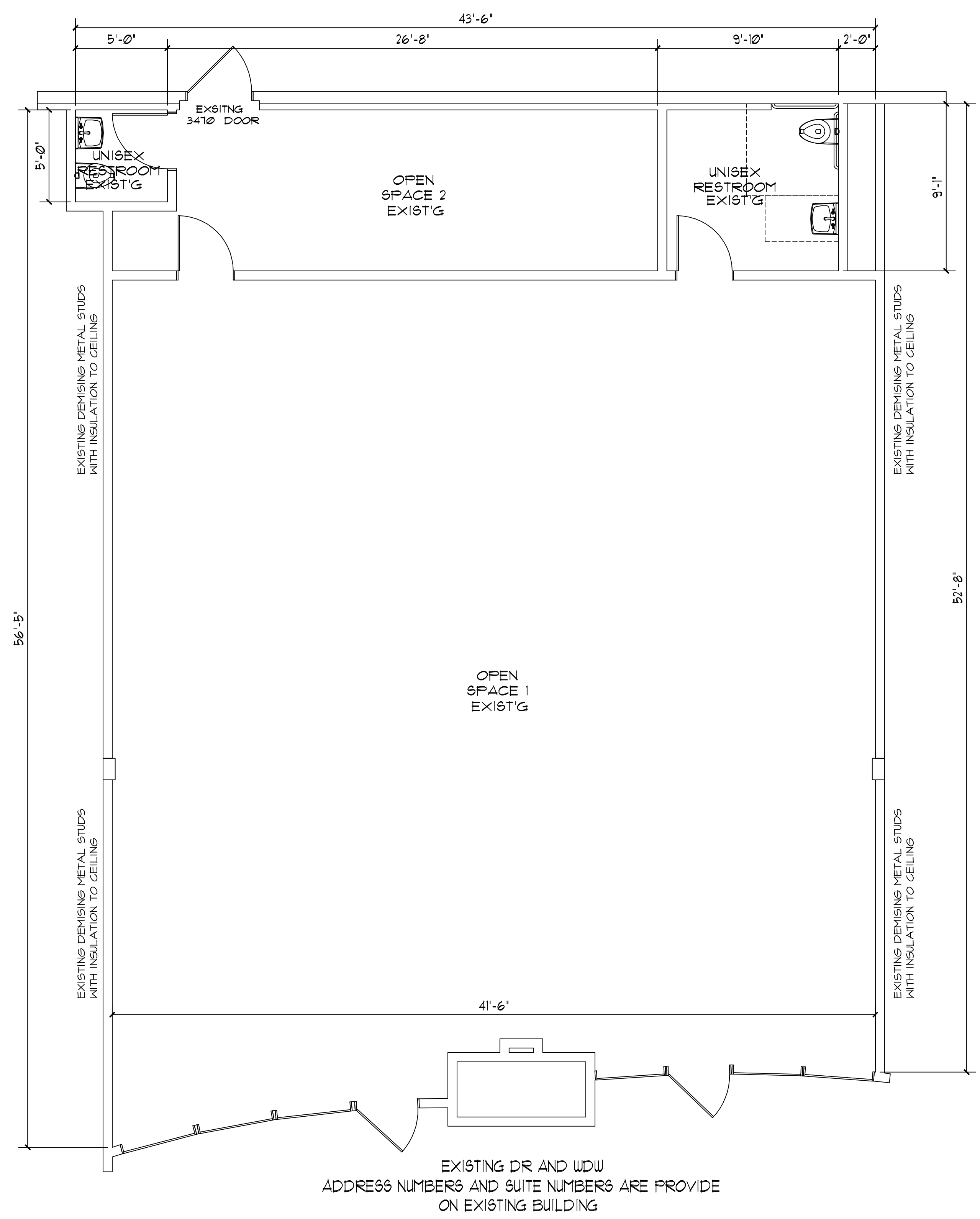

Existing Floorplan

LEGEND
 EXISTING WALLS TO BE REMOVE [dashed line]
 EXISTING WALLS TO REMAIN [solid line]
 NEW WALLS [thick solid line]

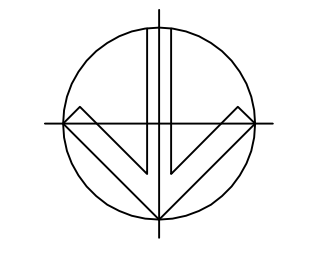

NOTICE
 THE CONTRACTOR SHALL INSPECT ALL EXISTING CONDITIONS AND AREAS TO BE MODIFIED TO VERIFY THE CONDITIONS MATCH THE CONSTRUCTION DOCUMENTS PRIOR TO STARTING ANY WORK. IF CONDITIONS ARE DIFFERENT THEN SHOWN, THE CONTRACTOR SHALL NOTIFY DESIGNER OF RECORD OF THE ACTUAL CONDITION. THE CONTRACTOR SHALL NOT PROCEED PRIOR TO NOTIFICATION FROM THE DESIGNER OF RECORD AND RECEIVING INSTRUCTIONS OR DRAWINGS THAT MAY BE REQUIRED.

EXISTING TRUSSES

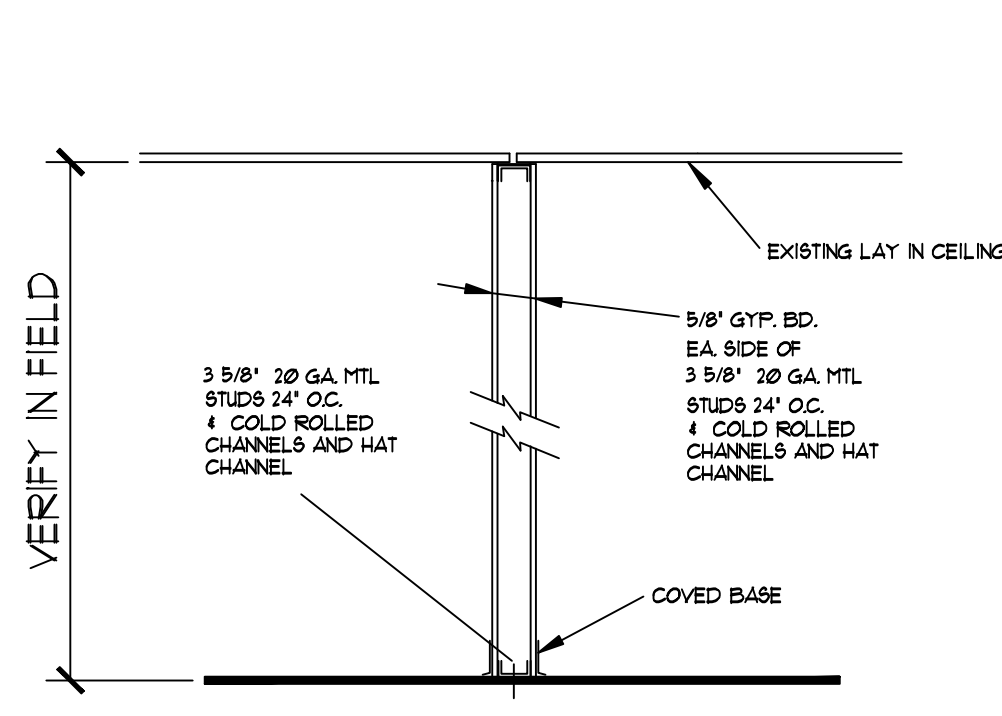

1 INTERIOR WALL SCALE: N.T.S

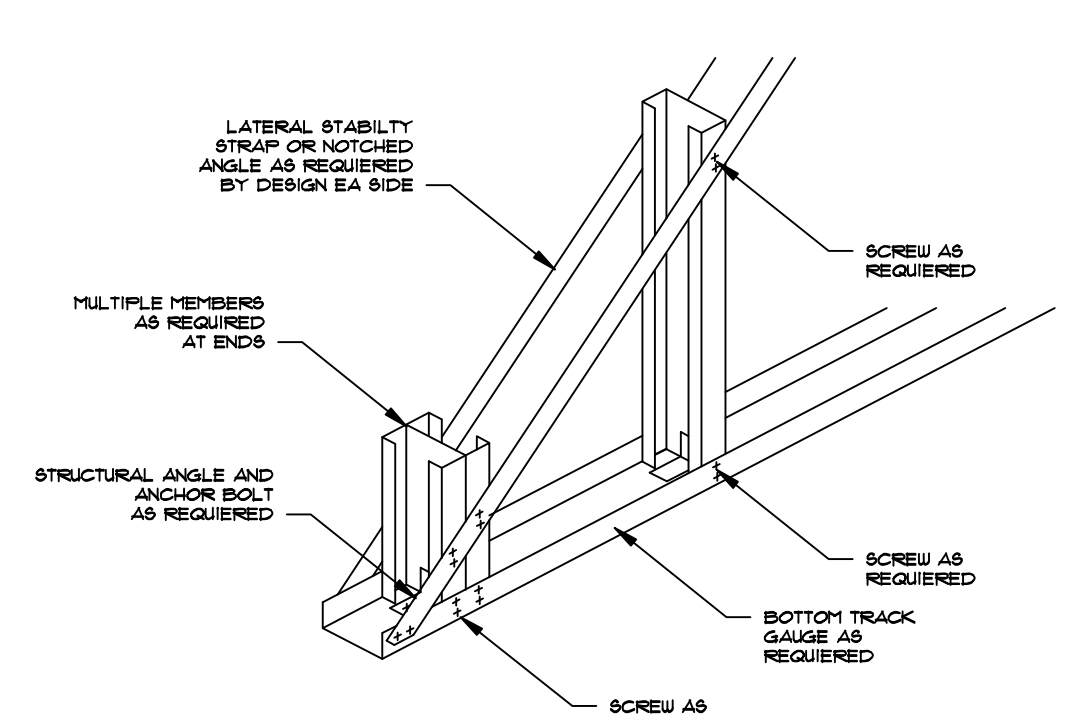

2 DETAIL FOR BRACING SCALE: N.T.S

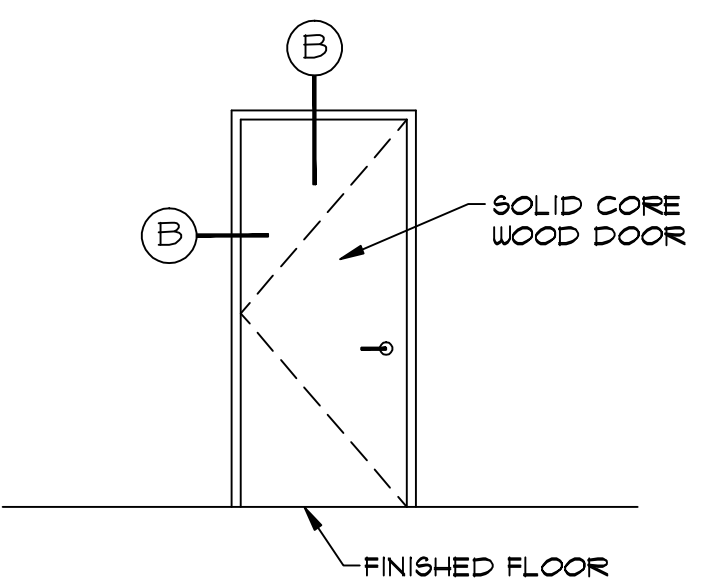

A TYPICAL DOOR DETAILS SCALE: N.T.S

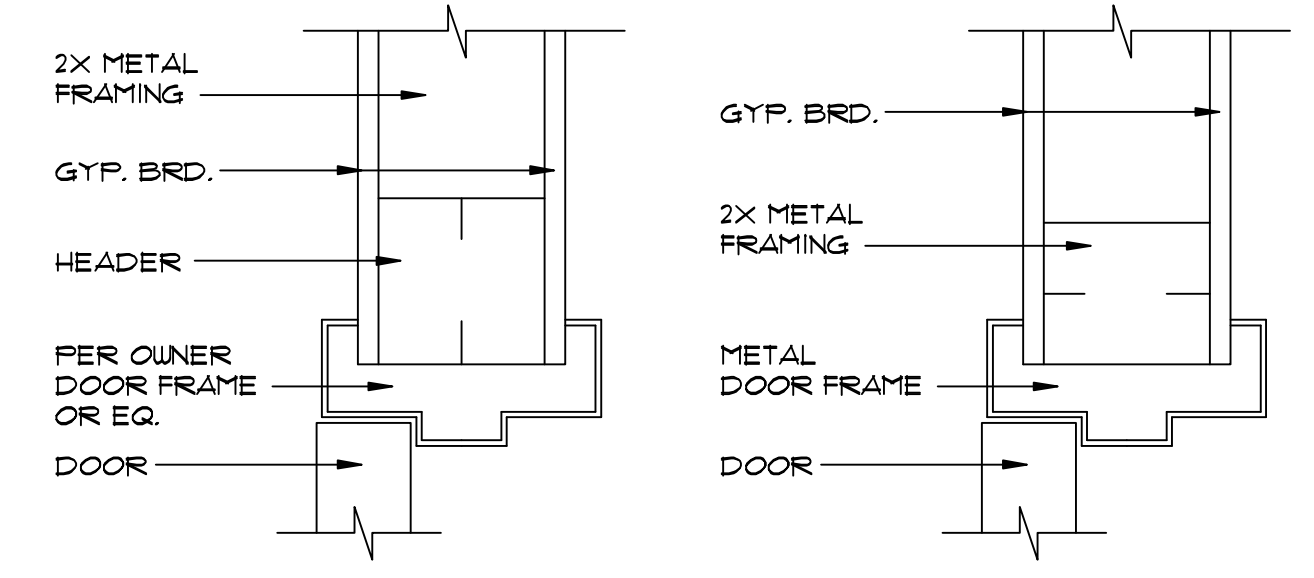

B HEAD/JAMB SCALE: N.T.S

3 TYPICAL DOOR DETAILS SCALE: N.T.S

1 PLAN KEY NOTES

- EXISTING EXTERIOR WALL, TO REMAIN.
- EXISTING ENTRY DOOR.
- EXISTING GLASS & ALUM. WINDOW SYSTEM
- NEW INTERIOR 3 5/8" 20 GA. METAL STUD. UNDER SIDE OF CEILING
- NOT USED
- EXISTING ELECTRICAL PANEL
- PROVIDE A NEW FIRE EXTINGUISHER PER NORTHWEST IN WALL MOUNTED CABINET
- NEW 3070 DOOR PER BUILDER/OWNER
- MOP SINK WITH EXISTING WATER HEATER ABOVE
- DRINKING WATER DISPENSER
- WASHER / DRYER PER OWNER
- SINK - PER OWNER

GENERAL REQUIREMENTS

- THE OWNER'S SUBCONTRACTORS MAY OCCUPY PORTIONS OF THE PROJECT DURING THE FINAL STAGE OF CONSTRUCTION. COORDINATE AND COOPERATE WITH THE OWNER TO MINIMIZE CONFLICT AND FACILITATE THE OWNER'S OPERATION.
- ALL DIMENSIONS AND FINISHES SHALL BE VERIFIED AND COORDINATED WITH EXISTING CONDITIONS PRIOR TO CONSTRUCTION, FABRICATION, OR PURCHASING. IN CASE OF CONFLICT BETWEEN THE PROJECT REQUIREMENTS AND/OR EXISTING CONDITIONS, THE ONE HAVING THE MOST STRINGENT REQUIREMENTS SHALL GOVERN, AS APPROVED BY THE OWNER.
- PERFORM ALL WORK IN ACCORDANCE WITH ACCEPTABLE TRADE PRACTICE TO INSURE THE HIGHEST QUALITY FINISHED PRODUCT - EXPRESSED OR IMPLIED. PERFORM ALL WORK BY SKILLED MECHANICS IN ACCORDANCE WITH ESTABLISHED STANDARDS OF WORKMANSHIP IN EACH OF THE VARIOUS TRADES.
- COORDINATE BLOCKING REQUIREMENTS WITH ADJACENT OR RELATED TRADES, ACCESSORIES, EQUIPMENT AND FIXTURES. INSTALL REQUIRED BLOCKING AT NO ADDITIONAL COST TO THE CONTRACT.
- REPAIR PROPERTY DAMAGE BY THE INSTALLERS TO A LIKE NEW CONDITION OR REPLACE DAMAGED SURFACES AND MATERIALS OF THE PREVIOUSLY INSTALLED WORK BY OTHER TRADES, INSTALLERS AND SUBCONTRACTORS.
- WHERE REQUESTED BY THE OWNER TO CERTIFY CONFORMANCE TO TRADE STANDARDS OR THE PROJECT REQUIREMENTS, THE CONTRACTOR SHALL ENLIST A TESTING LABORATORY AT THE OWNER'S COST. IF THE REQUESTED TEST SHOWS NON-COMFORMANCE TO GENERALLY ACCEPTED TRADE STANDARDS OR THE PROJECT REQUIREMENTS, THE CONTRACTOR SHALL CORRECT THE DEFICIENCY AT NO ADDITIONAL COSTS TO THE OWNER AND REIMBURSE ALL THE COSTS OF THE TESTING TO THE OWNER, UNLESS THE CONTRACTOR HAS USED PRODUCTS INCORRECTLY LABELED BY THE MANUFACTURER OR HAS MADE PREVIOUSLY APPROVED CHANGES.
- PROVIDE SECURITY OF THE WORK, INCLUDING TOOLS AND UNINSTALLED MATERIALS. PROTECT THE WORK, STORED PRODUCTS, CONSTRUCTION EQUIPMENT AND OWNER'S PROPERTY FROM THEFT AND VANDALISM AND THE PREMISES FROM ENTRY BY UNAUTHORIZED PERSONNEL UNTIL FINAL ACCEPTANCE BY OWNER.
- MAINTAIN AN ACTIVE FIRE EXTINGUISHER AT THE PROJECT.
- DO NOT USE MATERIAL OR EQUIPMENT FOR ANY PURPOSE OTHER THAN THAT FOR WHICH IT IS SPECIFICALLY DESIGNED OR SPECIFIED. ALL MATERIALS AND EQUIPMENT THAT ARE SIMILAR SHALL BE THE SAME TYPE, MODEL, AND STYLE FOR THE SAME USE THROUGHOUT THE PROJECT OR THEY SHALL BE REJECTED.
- WHEN THE PROJECT REQUIREMENTS REQUIRE THAT THE INSTALLATION OF WORK SHALL COMPLY WITH MANUFACTURER'S INSTRUCTIONS, PERFORM THE WORK IN STRICT ACCORDANCE WITH THE MOST CURRENT WRITTEN MANUFACTURER'S INSTRUCTIONS.
- ALL PRODUCTS AND EQUIPMENT SHALL BE DELIVERED IN UNDAMAGED CONDITION AND STORED IN ACCORDANCE WITH MANUFACTURER'S INSTRUCTIONS TO AVOID DISRUPTION OF THE WORK OR DAMAGE TO THE ITEMS. REPLACE DAMAGED OR UNFIT MATERIALS, AT NO COST TO THE OWNER.
- NOTIFY THE OWNER WHEN THE WORK IS SUBSTANTIALLY COMPLETE AND READY FOR FOR INSPECTION. UPON INSPECTION, PROVIDE WRITTEN OPERATION AND MAINTENANCE INSTRUCTIONS AND GUARANTEES FOR ALL EQUIPMENT AND MATERIALS INSTALLED. PROVIDE WRITTEN GUARANTEES FOR A PERIOD OF ONE (1) YEAR FROM THE DATE OF FINAL ACCEPTANCE OF THE WORK.
- PROVIDE FINAL CLEANUP AND DAMAGE REPAIR AT THE PROJECT CONCLUSION. LEAVE THE PREMISES NEAT, CLEAN AND CLEAR OF TOOLS, EQUIPMENT AND SURPLUS MATERIALS, UNLESS REQUESTED BY THE OWNER. CLEANUP SHALL INCLUDE AND NOT BE LIMITED TO:
 - POWER VACUUMING THE ENTIRE SPACE.
 - HAND DUSTING AND CLEANING OF ALL SHELVING, CABINETRY, CASEWORK, GLASS AND MIRRORS BOTH INSTALLED UNDER THIS CONTRACT OR EXISTING WALLS, CEILINGS, FIXTURES, ETC.
 - REPAIR OR REPLACEMENT OF PROPERTY DAMAGED DURING FINAL COMPLETION OF THE PROJECT.

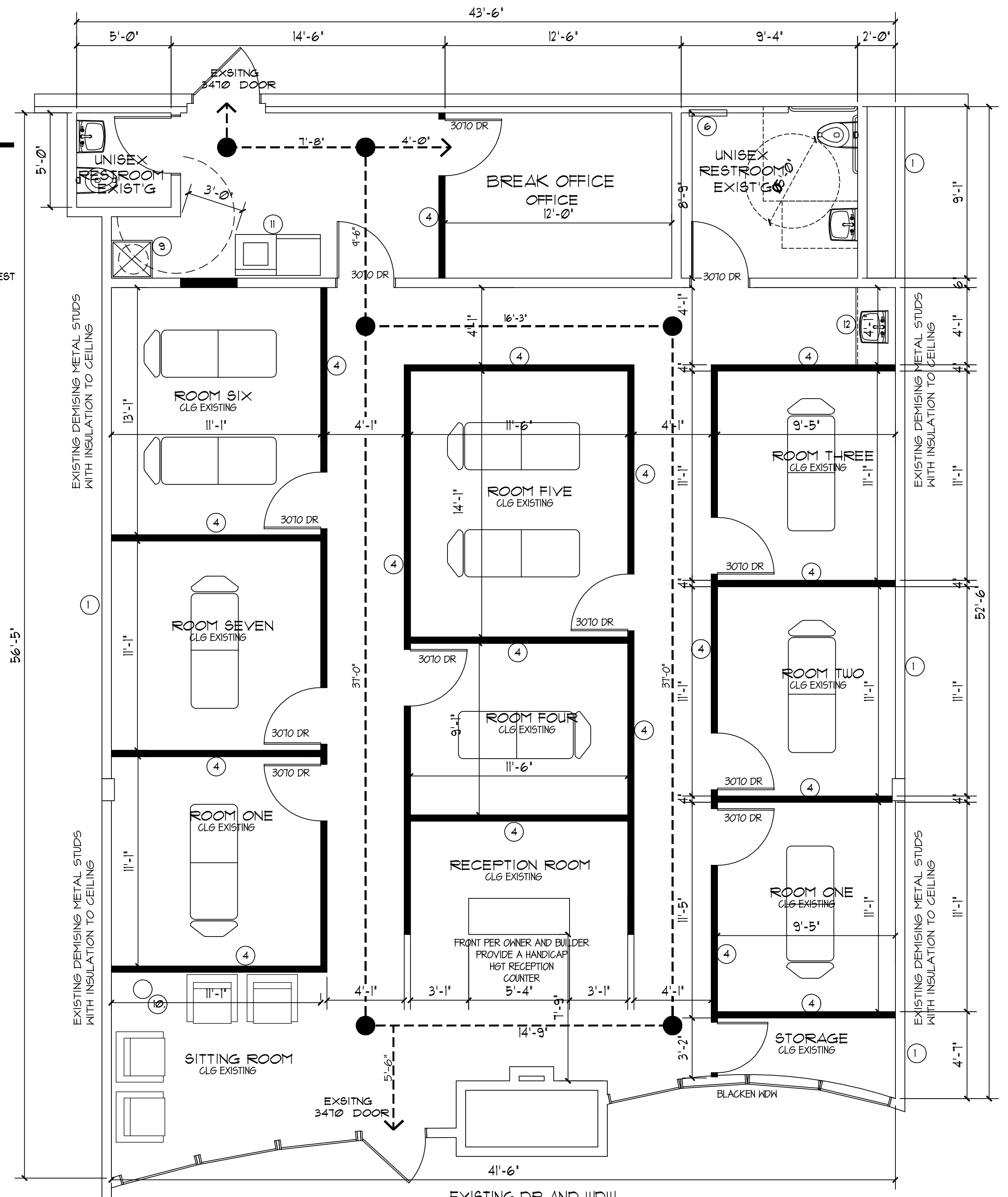

EXISTING DR AND WDW ADDRESS NUMBERS AND SUITE NUMBERS ARE PROVIDE ON EXISTING BUILDING

Proposed Floorplan

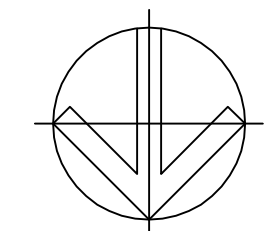
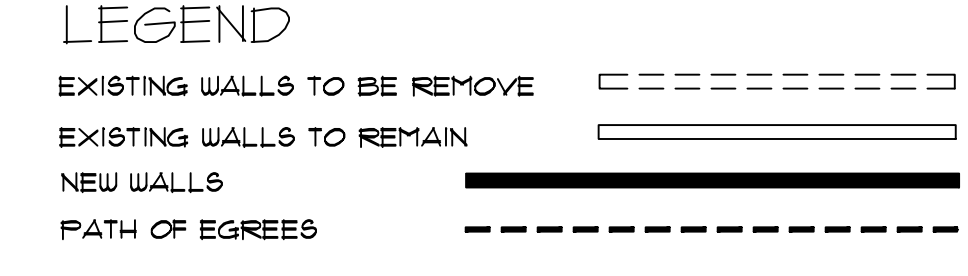

NOTICE
THE CONTRACTOR SHALL INSPECT ALL EXISTING CONDITIONS AND AREAS TO BE MODIFIED TO VERIFY THE CONDITIONS MATCH THE CONSTRUCTION DOCUMENTS PRIOR TO STARTING ANY WORK. IF CONDITIONS ARE DIFFERENT THEN SHOWN THE CONTRACTOR SHALL NOTIFY DESIGNER OF RECORD OF THE ACTUAL CONDITION. THE CONTRACTOR SHALL NOT PROCEED PRIOR TO NOTIFICATION FROM THE DESIGNER OF RECORD AND RECEIVING INSTRUCTIONS OR DRAWINGS THAT MAY BE REQUIRED.

REVISION DATE: INITIAL:

 STAMP:

 EXP. DATE 12 / 31 / 2023

INSIGHTDESIGN LLC
 GLENDALE, AZ 85318
 CONTACT: MARK LEJUIS 623-341-6514
 ARCHITECTURAL CONCEPTS, INC. (ASSOCIATE ARCHITECT (IND))
 FOUNTAIN HILLS, ARIZONA 85263



The River Message
 1845 East Broadway
 Suite 125 - 126
 Tempe, Arizona
 Contact: JT Song

DRAIN BY:
 CHECK BY:
 DATE:
 JOB No.:

SHEET CONTENTS:

SHEET No.:

A3
 OF SHEETS