

**CITY OF TEMPE  
DEVELOPMENT REVIEW COMMISSION**

**Meeting Date: 12/12/2023  
Agenda Item: 6**

**ACTION:** Request a Use Permit to allow a second-story walk deck addition for a single-family residence for the **LEWIS RESIDENCE**, located at 921 South Roosevelt Street. The Applicant is MNF Design Drafting & Planning LLC.

**FISCAL IMPACT:** N/A

**RECOMMENDATION:** Staff – Approve, subject to conditions

**BACKGROUND INFORMATION:** LEWIS RESIDENCE (PL230326) is requesting a proposed second-story 300 square foot roof-top deck over a one-story single-family residence on Lot 6 of the Goodwin Homes subdivision, located on the east side of South Roosevelt Street in the R-2, Multi-Family Residential District. This request was previously heard with modifications made to the design to address public comments and was approved by the Development Review Commission in 2020. An appeal of the request was denied by the City Council, upholding the Commission approval of the Use Permit, contingent upon obtaining building permits and final inspection of the construction. The building permits expired and the applicant is seeking a new Use Permit for the same prior request. The request includes the following:

ZUP230076 Use Permit to allow a second story addition for a roof-top deck on a single-family residence.

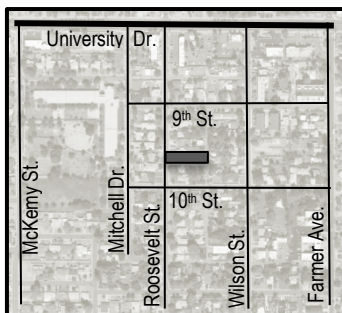

Property Owner	Lori B Lewis Trust
Applicant	Nathan Fowler, MNF Design, Drafting & Planning LLC
Zoning District(s)	R-2
Site Area	10,000 s.f.
Total Bedrooms	3
Total Bathrooms	3
Building Area	961 s.f. (existing house) + 66 s.f. (existing storage) + 1,006 s.f. (new livable) = 2,033 s.f.
Outdoor Area	311 s.f. patio + 300 s.f. rooftop deck, 306 s.f. carport
Lot Coverage	20% (45% max. required)
Building Height	18' (30'-0" maximum allowed)
Building Setbacks	29'-0" front west, 3' 1" existing north side, 8' 3" existing south side, 86' rear east (20' front, 10' side, 15' rear required in R-2) (prior use permit and building permits approved with existing conditions on site)
Vehicle Parking	2 spaces, 1 in carport, 1 tandem in driveway (2 min. required for single family)

**ATTACHMENTS:** Development Project File

**STAFF CONTACT(S):** Diana Kaminski, Senior Planner (480) 858-2391

Department Director: Jeff Tamulevich, Community Development Director

Legal review by: N/A

Prepared by: Diana Kaminski, Senior Planner

Reviewed by: Michelle Dahlke, Principal Planner

## COMMENTS

The site is located south of University Drive, north of 13<sup>th</sup> Street, east of McKemy Street and west of Farmer Avenue within the Goodwin Homes Subdivision and the Wilson Art and Garden Neighborhood Association. The area is also located within Character Area Three: Downtown Tempe/Rio Salado/ASU/NW Neighborhoods Character Area. The proposed project includes the existing 973 square foot residence with a 1,006 square foot addition on the ground floor, retaining the existing single-car carport and 66 square foot storage room. The remodeled single-family residence would include three bedrooms and three bathrooms, a dining room, kitchen, great room and laundry room. The proposed second story is to accommodate an exterior stairwell leading to a second-floor roof deck. The site is registered with the county as a single-family residential property to be occupied by the son of the owner. The proposed project received entitlements in April of 2020 and the building permits expired in 2022. The expiration of the building permit resulted in expiration of the Use Permit, requiring the owner to apply for a new Use Permit for the same request.

## PUBLIC INPUT

To date, staff has received one email of inquiry and one public comment in opposition to this request, both were from residents within the immediate area of the subject site.

## USE PERMIT

The proposed use requires a Use Permit to allow a second story addition to a single-story single-family residence for the purpose of building a roof-top deck within the R-2 zoning district. The applicant provided a letter of explanation and plans outlining the design intent and how the request meets the criteria.

Section 6-308(E) Approval criteria for Use Permit (*in italics*):

1. *Any significant increase in vehicular or pedestrian traffic*; The proposed residence is 2,033 s.f. and has 3 bedrooms, similar to most single-family homes of this size. The site can accommodate two vehicles parked in tandem on the north side of the house within a one-car carport and on the drive, with room for one guest space parked on street. The addition of a second story 300 square foot roof deck is over the eastern portion of the house and does not add to the livable area of the residence. Based on the proposed single-family use and size and available parking, it is not anticipated that the second story addition will increase vehicular or pedestrian traffic.
2. *Nuisance arising from the emission of odor, dust, gas, noise, vibration, smoke, heat or glare at a level exceeding that of ambient conditions*; The site is within a quarter of a mile of an active railroad track, arterial street, downtown Tempe and less than a mile from the airport flight path. The proposed second story deck is proposed to have a 72" high privacy screen surrounding the deck.
3. *Contribution to the deterioration of the neighborhood or to the downgrading of property values, which is in conflict with the goals, objectives or policies for rehabilitation, redevelopment or conservation as set forth in the city's adopted plans or General Plan*; The existing structure as appears from the exterior has not had any significant renovations or upgrades since constructed in 1951. The site is zoned for multi-family use; however the character of the area is predominantly single-family homes on similar lots. The existing 973 square foot home is being expanded to include a more livable footprint for contemporary living while keeping the existing street front character with the ground floor addition to the rear of the building and setting the second story addition back from the existing structure to minimize visual impact to the existing house. Maintaining the existing structure facilitates the goals and objectives of neighborhood preservation and community revitalization. This second story addition will not contribute to the deterioration of the surrounding area, but rather bolster the sense of place that makes the area unique.
4. *Compatibility with existing surrounding structures and uses*; the surrounding neighborhood consists of mostly single-story homes with a few multi-story homes. This home will continue to appear as a single-story home and is compatible with the existing surrounding structures as the original established pattern of development in Tempe. Any property zoned single family or multi-family is allowed to build up to 30' tall, the proposed building height with rooftop deck is 18' tall. If this were proposed as a multi-family development it would not need the use permit for the second story addition but

could build by right by the zoning development standards. Choosing to maintain a single-family use on a multi-family zoned lot triggers the requirement for the Use Permit for the second story. Other two-story properties within this area include:

- 1225 S. Wilson, a two-story multi-family residence approved in 2011 with a Use Permit for tandem parking approved in 2013.
- 1229 S. Wilson, a two-story multi-family residence approved in 2002.
- 1136 S. Roosevelt Street, a two-story single-family residence approved in 2013 with Use Permit Standard reductions for the street side yard and front yard setbacks from 20 feet to 16 feet.
- 1135 S. Roosevelt Street, a two-story single-family residence approved in 2006.
- At 9<sup>th</sup> Street and Wilson have 2 two-story apartments on the north east corner and two-story single-family homes on the south east corner.

5. *Adequate control of disruptive behavior both inside and outside the premises which may create a nuisance to the surrounding area or general public;* The second-story deck is intended for a single-family use by a family member responsible for maintaining and enforcing behavior on site pursuant to the city codes and ordinances. The deck was reduced in size from 500 square feet to 300 square feet with the prior application and added visual screening around perimeter of deck for privacy and a landscape buffer on the south side where the exterior stairwell is located.

#### **REASONS FOR APPROVAL:**

Based on the information provided by the applicant, the prior Development Review Commission and City Council findings of support for this same request and the above analysis, staff supports the requested Use Permit. This request meets the required criteria and will conform to the conditions.

#### **SHOULD AN AFFIRMATIVE ACTION BE TAKEN ON THIS REQUEST, THE FOLLOWING NUMBERED CONDITIONS OF APPROVAL SHALL APPLY, BUT MAY BE AMENDED BY THE DECISION-MAKING BODY.**

**CONDITION(S) OF APPROVAL: (Non-standard conditions are identified in bold)** EACH NUMBERED ITEM IS A CONDITION OF APPROVAL. THE DECISION-MAKING BODY MAY MODIFY, DELETE OR ADD TO THESE CONDITIONS.

1. The Use Permit for a 300 square foot second story roof deck is valid only after a Building Permit has been obtained, the required inspections have been completed and a Final Inspection has been passed. As part of the Building Permit process, on-site storm water retention may be required to be verified or accomplished on this Site.
2. The Use Permit is valid for the plans as submitted within this application. Any additions or modifications may be submitted for review during the building plan check process.
3. **Proposed modifications to existing 6' perimeter walls shall be coordinated with adjacent property owners. Any wall taller than 7' in height requires a building permit. If the existing 6' walls are dooley walls and are not able to be added onto, then replacement of the wall to meet the proposed height specified shall require owner authorization from adjacent property owner for removal and replacement with an 8"x8"x16" CMU block wall.**
4. **A landscape buffer shall be added on the ground level adjacent to the addition on the north and south sides of the structure to provide a mature plant height of 10-20' without impact to walls.**
5. **A landscape buffer shall be added on the ground level adjacent to the addition on the north and south sides of the structure to provide a mature plant height of 10-20' without impact to walls.**
  - a. **If raised planter box is used, the box shall be independent of the existing cmu wall with water barrier between wall and planter to avoid damage to existing wall.**
  - b. **Ficus nitida shall not be used as a hedge adjacent to the block walls on either side of the property.**
  - c. **If narrow trees or tall shrubs are proposed in the planter box on the south side, plants should be planted 3' from the existing wall and spaced horizontally to fill the space depending on plant species and planted size.**

## CODE/ORDINANCE REQUIREMENTS:

THE BULLETED ITEMS REFER TO EXISTING CODE OR ORDINANCES THAT PLANNING STAFF OBSERVES ARE PERTINENT TO THIS CASE. THE BULLET ITEMS ARE INCLUDED TO ALERT THE DESIGN TEAM AND ASSIST IN OBTAINING A BUILDING PERMIT AND ARE NOT AN EXHAUSTIVE LIST.

### USE PERMIT:

- The use permit approval shall be void if the use is not commenced or if an application for a building permit has not been submitted, whichever is applicable, within twelve (12) months after the use permit is granted or within the time stipulated by the decision-making body.
- The decision-making body, upon finding that the applicant has not taken corrective actions to resolve issues related to the permit/approval and that a continuation of the permit/approval is not in the interest of the public health, safety and general welfare, can revoke the permit/approval after providing written notice of its intentions to the holder of the permit.
- Specific requirements of the **Zoning and Development Code (ZDC)** are not listed as a condition of approval but will apply to any application. To avoid unnecessary review time and reduce the potential for multiple plan check submittals, become familiar with the ZDC. Access the ZDC through <http://www.tempe.gov/zoning> or purchase from Development Services.
- Any intensification or expansion of use shall require a new Use Permit.
- All required Federal, State, County, and Municipal permits, licenses, and clearances shall be obtained, or the Use Permit is void.

### HISTORY & FACTS:

March 20, 1914	The Common Council of the Town of Tempe approved the Goodwin Homes Subdivision Plat establishing lots, blocks and streets bounded by 8 <sup>th</sup> Street (now University Drive) to the north, Farmers Avenue to the east, 11 <sup>th</sup> Street to the south and Roosevelt Street to the west. The subject site recorded as Lot 6 of Block 5 with dimensions of 50' wide by 200' deep established within the plat.
1930-1940s	Historic Aerials indicate the site was used for agricultural purposes.
April 14, 1938	Tempe established the first Zoning Ordinance 177, all new construction after this date would conform to the standards established by the code. This site was established with the zoning district of "Residence District" allowing single-family uses and not specifying development standards.
August 12, 1948	Zoning Ordinance 193 was approved, the site was designated "Residence A" in a further delineation of residential types, "A" being single family and "B" being multi-family. Development standards were established with minimum lots of 6,000 s.f. and 50' width. Lot coverage not to exceed 40% and front yard setbacks of 25'. The side yard setbacks were established at 7' with special provisions for lots without alley access. This lot has alley access established but not dedicated, the rear portion of the property line extends to the centerline of the current alley. The rear yard setback was established at 15'.
1949	Surrounding lots were developed, with the subject site remaining vacant.
1951	Building Permit issued for the subject site. Aerial images are not clear to roofline and property line locations but appear to be similar in later aerial images with the existing rooftop footprint with a carport and storage shed located on the north side yard.

January 14, 2020	Development Review Commission continued a request for a Use Permit to allow a second-story walk deck addition for a single-family residence for the LEWIS RESIDENCE, located at 921 S Roosevelt Street. The Applicant is Danny Niemela of ArDan Construction. (PL190295)
February 11, 2020	Development Review Commission approved the request for <b>LEWIS RESIDENCE</b> , located at 921 South Roosevelt Street. The site is in the R-2 (Multi-Family Residential) zoning district. This approval will allow a second-story walk deck addition for a single-family residence. The request included the following: ZUP190084 Use Permit to allow a second story walk deck addition for a single-family residence.
April 23, 2020	City Council denied an appeal by Karen Morrissey of 917 South Roosevelt Street of the Development Review Commission decision to approve the Use Permit for a second story walk deck. The denial of the appeal upheld the original decision to approve the Use Permit.
September 5, 2020	Building Permits were routed for review, corrections were required and subsequent resubmittals and reviews were conducted and had an original expiration date of 9/02/2021. The applicant requested and qualified for a one-time extension per the Mayor's Proclamation which grants projects an additional year, the project received the time extension with a new expiration date of 10/31/2022.
August 22, 2022	The project received building permit approval from plan review along with a notice from the Permit Center on 8/22/2022 (before expiration date) that permits were ready to issue pending payment.
October 31, 2022	Permit fees were not paid and the project expired. As a result of the expiration of the building permit, the applicant was required to submit for a new Use Permit.

**ZONING AND DEVELOPMENT CODE REFERENCE:**

[Section 3-102, Permitted Uses in Residential Districts](#)

[Section 3-420, Single-Family Residential Second Story Addition or Rebuild](#)

[Section 6-308, Use Permit](#)

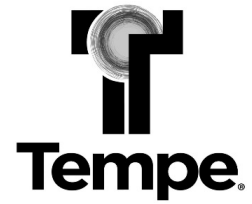

# DEVELOPMENT PROJECT FILE

for

LEWIS RESIDENCE  
(PL230326)

## **ATTACHMENTS:**

- 1-3. Site Context (Location Map, Aerial and Site Photos)
- 4-5. Applicant's Letter of Explanation
- 6-8. Cover Page, Site Plan, Floor Plan
- 9-11. Elevations and Details
- 12-22. Public Input

# LEWIS RESIDENCE

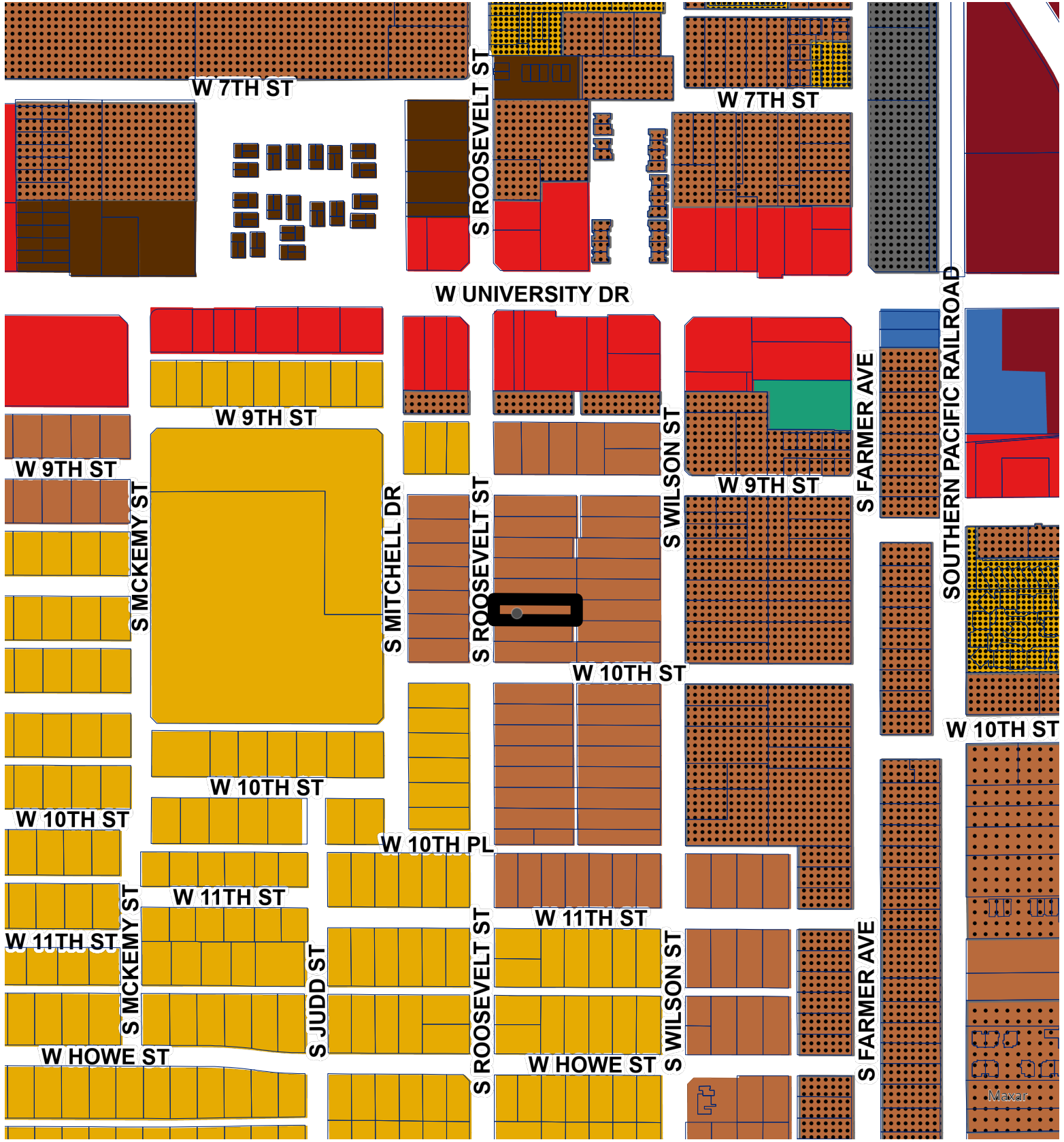

- General Industrial District (GID)
- City Center (CC)
- Mixed Use High (MU-4)
- Commercial Shopping and Services (CSS)
- Residential/Office (RO)
- Single-Family Residential (R1-6)
- Single-Family Residential Planned Area Dev (R1-PAD)

- Multi-Family Residential (R-2)
- Multi-Family Residential Restricted (R-3R)
- Multi-Family Residential Limited (R-3)
- Multi-Family Residential General (R-4)
- Parcels

- Twelve Point**  
CenterlineSubType
- ADOT
  - Canal
  - Monument
  - Private

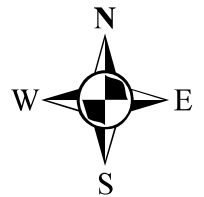



LEWIS RESIDENCE

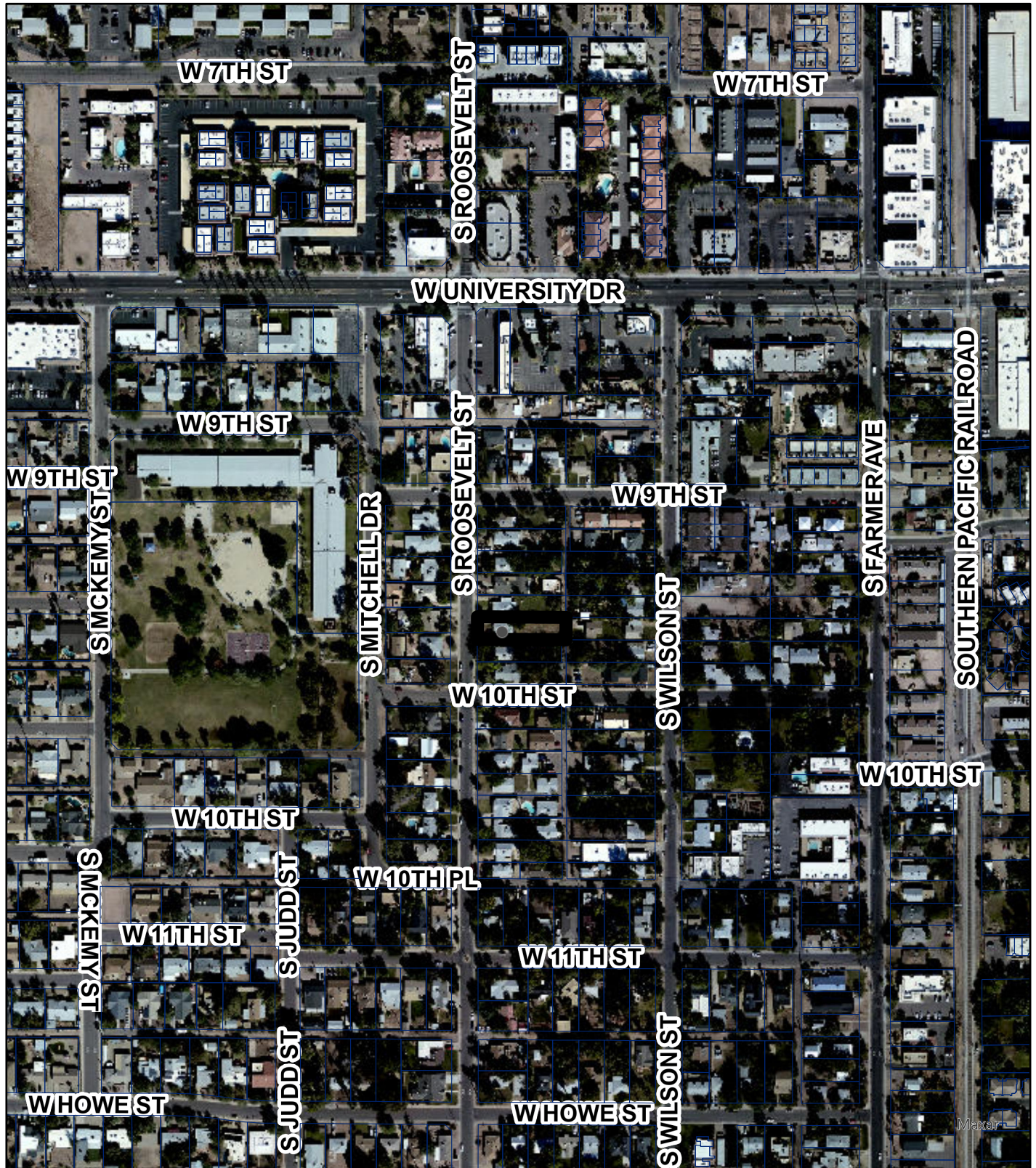

Aerial Map

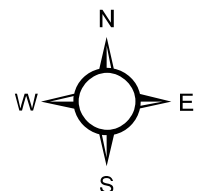





NW



SW



NE



SE



NORTH PROPERTY LINE



BACK PATIO - NE CORNER STRUCTURE



STREET VIEW

THESE DRAWINGS ARE THE INSTRUMENTS OF SERVICE AND PROPERTY OF JMC DESIGN, DRAFTING & PLANNING, LLC. THESE PLANS ARE NOT TO BE REPRODUCED, ALTERED OR COPIED IN ANY FORM OR ASSIGNED TO ANY THIRD PARTY WITHOUT WRITTEN APPROVAL.

**JMC**  
design, drafting, planning  
1122 S. W. Peach Street  
Tempe, AZ 85281

**PROJECT**  
LEWIS ADDITION  
921 S. ROOSEVELT ST.  
TEMPE, AZ 85281

**PROJECT**

**EXTERIOR IMAGES**

REVISIONS

Δ - USE PERMIT 11/1/23

\_\_\_\_\_

\_\_\_\_\_

\_\_\_\_\_

\_\_\_\_\_

\_\_\_\_\_

\_\_\_\_\_

\_\_\_\_\_

\_\_\_\_\_

\_\_\_\_\_

\_\_\_\_\_

\_\_\_\_\_

\_\_\_\_\_

\_\_\_\_\_

\_\_\_\_\_

\_\_\_\_\_

\_\_\_\_\_

\_\_\_\_\_

\_\_\_\_\_

PLOT DATE: 11/02/23

SHEET NO.

**A3**

# LETTER OF EXPLANATION

## LEWIS RESIDENCE

921 S Roosevelt St Tempe AZ 85281

Nathan Fowler · MNF Design · [nathan@mnfdesignllc.com](mailto:nathan@mnfdesignllc.com) · 480-332-7300

City of Tempe  
Community Development Department  
Planning Division  
31 E 5<sup>th</sup> St, Garden Level East  
Tempe AZ 85281

### DEAR DIVISION OF PLANNING,

This property is currently a single-family residence. Lori Lewis is planning on remodeling and updating the home to make it more functional and aesthetically pleasing. Part of the remodel is an addition to the home that will include a 2<sup>nd</sup> level 300 S.F. walk deck. The purpose of this walkdeck is to allow additional patio/seating area outdoors but still allows for an open and irrigated back yard. The exterior placement of the stair up to the roof deck is critical to the design due to the limitations of the building footprint caused by the setbacks. Proposing the staircase inside the patio on the northeast or inside the living space was considered during the design process but proved to be intrusive to the flow to and from the backyard. In addition, the placement of the stairs on the interior simply requires too much space that we can not make up for by expanding our building footprint due to cost limitations as well as the side setbacks. In addition, this home is designed to reflect a single-story structure with a roof deck with the highest portion of the roof at 15'-6" from the finished grade. Locating the stairs inside would require an additional roof structure to provide for a landing at the top but we did not want to add any additional height or an element that would be proportionally displeasing. Locating the staircase outside satisfies our space needs and allows us to incorporate it into the screen element for the deck which is a necessary privacy element that was included to obtain approval for the original use permit.

This addition will not be detrimental to the persons residing or working in the vicinity, to adjacent properties, to the neighborhood, or the public welfare in general and will conform to the standards and Zoning and Development Code Criteria as applicable. The prior use permit did receive public input and the approved use permit reflected the changes requested by the public. This submittal does not propose any changes to the original approved use permit and will not create additional foot traffic or vehicular presence. The home remains a single-family home for Lori Lewis's son and is not intended for rental or student housing. Concerns about noise and light emission were addressed by reducing the size of the deck from almost 600 s.f. down to 300 s.f. and screening the staircase on both sides of the Waldeck to prevent any line of sight into

neighboring homes and to deflect noise while keeping the lighting low and below the screening. In addition, we have proposed adding 1 course of block to the existing south wall and additional planting if necessary and with these improvements the property should affectively control any disruptive nuisance.

The remodel of this home will greatly contribute to the neighborhood and the surrounding area that is consistent with owners who are improving their properties and invite innovative and fresh ideas and looks contributing to strong property value. It is compatible with a consistently evolving neighborhood and remains appropriately sized for the lot and maintains appropriate height for a single-story structure.

There are a few other homes in the neighborhood that have 2<sup>nd</sup> levels including:

1136 S Roosevelt St Tempe AZ 85281

1231 S. Wildon St.

1225 s Wilson St.

Thank You for your consideration.

*Nathan Fowler*

Nathan Fowler

MNF Design Drafting & Planning LLC

November 1, 2023

GENERAL ARCHITECTURAL NOTES

EXTERIOR MATERIALS: APPROVED CORROSION RESISTANT FINISHING SHALL BE PROVIDED AT EXTERIOR WINDOW AND DOOR OPERINGS... VICINITY MAP: A map showing the project location at the intersection of South Roosevelt Street and North 10th Street in Tempe, AZ. PROJECT DIRECTORY: DESIGN / DRAFTING: P&P DESIGN, DRAFTING & PLANNING, LLC... PROJECT DATA: BUILDING CODES: ALL CONSTRUCTION SHALL COMPLY WITH THE FOLLOWING CODES AND ANY AMENDMENTS... AREA CALC'S: FINISHABLE AREA: 961.50 SQ. FT., EXISTING FINISHABLE: 1,006.50 SQ. FT., TOTAL FINISHABLE AREA: 1,968.00 SQ. FT. ENERGY VALUE: COMPONENT: WINDOW / GLAZING, FACTOR: 0.40, RATIO: 0.25, ENERGY VALUE: 8-38.

VICINITY MAP

PROJECT DIRECTORY

PROJECT DATA

AREA CALC'S

Table with 2 columns: Category and Value. Includes rows for FINISHABLE AREA, EXISTING FINISHABLE, NEW FINISHABLE, TOTAL FINISHABLE AREA, NON-FINISHABLE AREA, EXISTING COVERED ENTRY, EXISTING STORAGE, EXISTING GARAGEPORT, NEW FRONT PATIO, NEW REAR PATIO, NEW DECK, TOTAL NON-LIVABLE AREA, TOTAL AREA, TOTAL FOOTPRINT, TOTAL FLOORING.

ENERGY VALUE

Table with 3 columns: Component, Factor, and Ratio. Includes rows for WINDOW / GLAZING, ENERGY VALUE, ATTIC, FRAMED WALLS (2nd), FRAMED WALLS (3rd), CEILING WALLS, AIR CONDITIONING, GAS FURNACE.

SHEET INDEX

Table with 2 columns: Sheet Number and Description. Includes rows for A01 PROJECT DATA, A02 ARCHITECTURAL SITE PLAN, A1 FLOOR PLANS, A3 EXTERIOR ELEVATIONS, A3 CONTEXT PHOTOS, A03 SCREEN DETAIL.

THESE DRAWINGS ARE THE INSTRUMENTS OF SERVICE AND PROPERTY OF THE FIRM. THESE PLANS ARE NOT TO BE REPRODUCED, ALTERED OR COPIED IN ANY FORM OR ASSIGNED TO ANY THIRD PARTY WITHOUT WRITTEN APPROVAL.



LEWIS ADDITION 921 S. ROOSEVELT ST. TEMPE, AZ 85283

PROJECT DATA

REVISIONS

Table for tracking revisions with columns for Description and Date.

PLOT DATE: 11/16/23 SHEET NO.

A0





**COLOR/MATERIAL LEGEND**



**SW-6258 TRICON BLACK**  
PARAPET WRAPPED w/ METAL



**SW-6076 TURKISH COFFEE**  
WOOD BEAM, WOOD SING, PRIVACY SCREEN



**SW-7005 PURE WHITE**  
STUCCO WALLS, POP-OUT

LIGHT REFLECTIVE VALUE < 75

**EQUIPMENT SCREEN**

- ROOF TOP EQUIPMENT SCREENING BY PARAPET WALLS...
1. ALL NEW EXTERIOR TECHNICAL EQUIPMENT NEEDS TO BE FULLY SCREENING. SEE CROSS-SECTION BELOW
  2. NO EXTERIOR DISPLAY OR VENDING SHALL BE ALLOWED.
  3. ALL EQUIPMENT, UTILITIES, OR OTHER APPURTENANCES ATTACHED TO THE BUILDING SHALL BE AN INTEGRAL PART OF THE BUILDING IN TERMS OF DESIGN, FORM, COLOR, AND TEXTURE

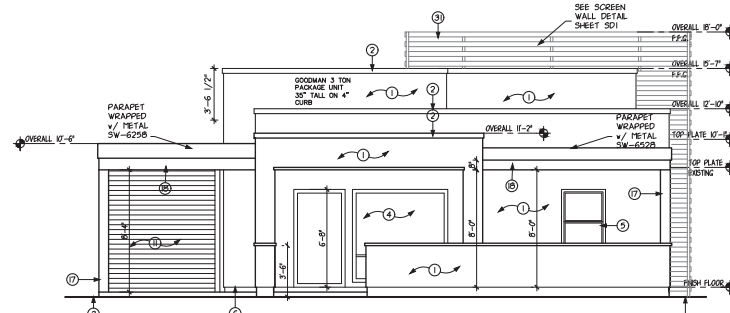

**WEST ELEVATION**  
SCALE: 1/4" = 1'-0"

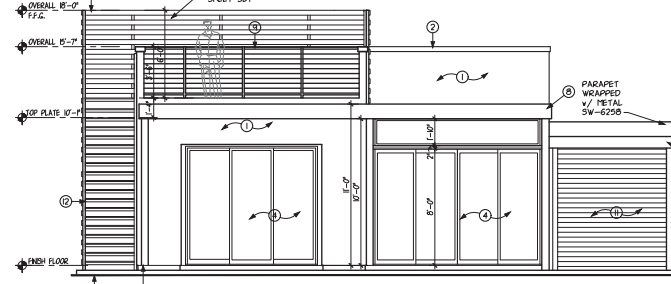

**EAST ELEVATION**  
SCALE: 1/4" = 1'-0"

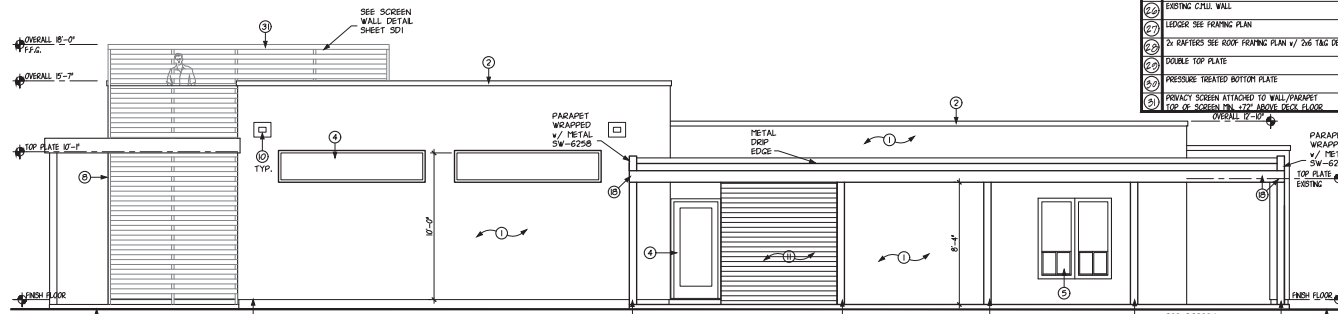

**NORTH ELEVATION**  
SCALE: 1/4" = 1'-0"

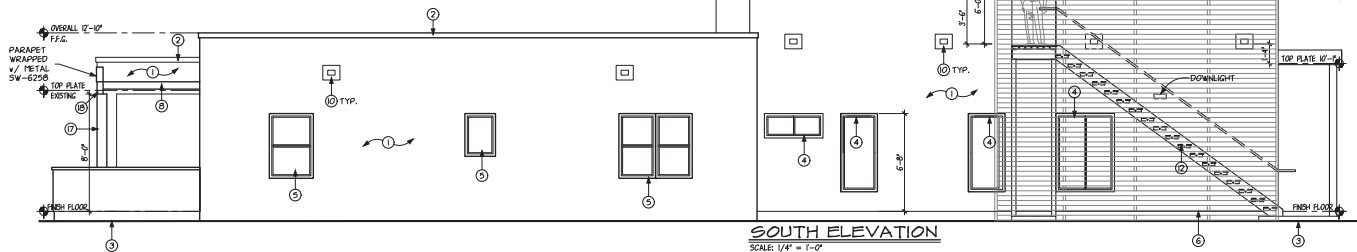

**SOUTH ELEVATION**  
SCALE: 1/4" = 1'-0"

**GENERAL INFO.**

1. FLASHING OF EXTERIOR OPENINGS SHALL COMPLY WITH I.B.C. SEC. 6702.8. ALL EXPOSED FLASHING SHALL BE PAINTED OR ANODIZED TO MATCH EXTERIOR COLOR. FOR OTHER UNDERLAYMENT AND FLASHING DETAILS SUCH AS ROOF PENETRATIONS
2. WEEP SCREED SHALL BE OF #3 GAUGE CORROSION-RESISTANT METAL w/ A MINIMUM VERTICAL ATTACHMENT FLANGE OF 3 1/2" & PLACED A MINIMUM OF 3/4" BELOW FINISH GRADE. FINISH GRADE SHALL BE ALL SET WALLS.
3. BUILT UP ROOFING w/ 3 LAYERS OF FELT & 50# PER SQ. FOOT OF GRAVEL OR OTHER APPROVED SUBSURING MATERIAL. METALLED PER MANUFACTURERS SPECS. AND I.B.C. SEC. 6703.4.
4. ALL WINDOW FRAMES SHALL BE PAINTED OR ANODIZED TO MATCH EXTERIOR COLOR - NO EXPOSED WOOD OR METAL
5. ALL VENTS, FLASHING, FASCIA, ELECTRICAL PANELS, ETC. TO BE PAINTED TO MATCH HOUSE.

**KEYNOTES**

No.	DESCRIPTION
1	3/8" STUCCO SYSTEM OVER 1" FOAM BOARD, LATH BASE OVER BUILDING PAPER - I.C.C. # ESR-2709
2	NO LATH @ CURB WALL - SW-7005 PURE WHITE
3	PARAPET w/ FRONT POP-OUT PER OWNER/BUILDER
4	FINISH GRADE - SLOPE 1/8" AWAY FROM BUILDING
5	NEW DOOR/WINDOW OPENING - SEE FLOOR PLAN
6	EXISTING DOOR/WINDOW OPENING - SEE FLOOR PLAN
7	WEEP SCREED TO FIN. 3/4" BELOW FINISH FLOOR - PAINT CONCRETE STEEL BELOW TO MATCH BUILD.
8	FOAM INSULATION EC-458-2550 OVER WPA GATED 2x6 T&G DECKING
9	NEW PREFAB LIGHT GAUGE ALUMINUM TRUSS SYSTEM SW-6076
10	METAL DRAINING - QUADRONAL # 108 FIN. w/ OPENINGS @ 4" OC. - 180 SERIES
11	SCUPPER w/ 2x4 POP-OUT
12	WOOD SING - SW 6076 TURKISH COFFEE
13	PRE MANUFACTURED STAIRS PER I.B.C. SEC. R34 (FIN. 082) 3/4" - FIN. 082(10)
14	STUCCO POP-OUT PARAPET CAP PER BUILDER
15	FOAM ROOFING EC-458-2550 OVER WPA GATED 2x6 T&G DECKING
16	SEE EC-458-2550 "FILL-DECK" WATERPROOF (EC-458-2550) w/ WPA GATED 2x6 T&G DECKING
17	EXTERIOR CIV. RD. OR EQUAL @ CIV. PATIOS (EC-458-2550 OR EQUAL)
18	NEW COLLIER STUCCO WRAPPED-SEE ROOF FRAMING PLAN
19	NEW WOOD BEAM - SEE ROOF FRAMING PLAN
20	SW 6076 TURKISH COFFEE
21	PRE-FAB FLOOR TRUSSES - SEE ROOF FRAMING PLAN
22	FINISH GRADE - SLOPE 1/8" AWAY FROM BUILDING
23	R-18 BATT INSULATION
24	R-38 BLOW-IN INSULATION
25	1/2" CEMENT BD. (ESR-3365 OR EQUAL)
26	CONCRETE SLAB w/ THERMITE TREATED A.B.C. FILL
27	EXISTING CHILL WALL
28	LEGOR SEE FRAMING PLAN
29	2x6 RAFTERS SEE ROOF FRAMING PLAN w/ 2x6 T&G DECK
30	DOUBLE TOP PLATE
31	PRESSURE TREATED BOTTOM PLATE
32	PRIVACY SCREEN ATTACHED TO WALL/ PARAPET TOP OF SCREEN FIN. 27" ABOVE EDGE FLOOR

THESE DRAWINGS ARE THE INSTRUMENTS OF SERVICE AND PROPERTY OF WNF DESIGN, DRAFTING & PLANNING, LLC. THESE PLANS ARE NOT TO BE REPRODUCED, ALTERED OR COPIED IN ANY FORM OR ASSIGNED TO ANY THIRD PARTY WITHOUT WRITTEN APPROVAL.



LEWIS ADDITION  
921 S. ROOSEVELT ST.  
TEMPLE, AZ 86281

PROJECT  
EXTERIOR ELEVATIONS & BUILDING SECTIONS

REVISIONS  
-  
PLOT DATE: 11/16/23  
SHEET NO.

**A2**

THESE DRAWINGS ARE THE INSTRUMENTS OF SERVICE AND PROPERTY OF JMF DESIGN, DRAFTING & PLANNING, LLC. THESE PLANS ARE NOT TO BE REPRODUCED, ALTERED OR COPIED IN ANY FORM OR ASSIGNED TO ANY THIRD PARTY WITHOUT WRITTEN APPROVAL.



LEWIS ADDITION  
0121 S. ROOSEVELT ST.  
TEMPE, AZ 85283

PROJECT

SCREEN DETAIL

REVISIONS

Δ	

PLOT DATE: 11/16/23  
SHEET NO.

SDI

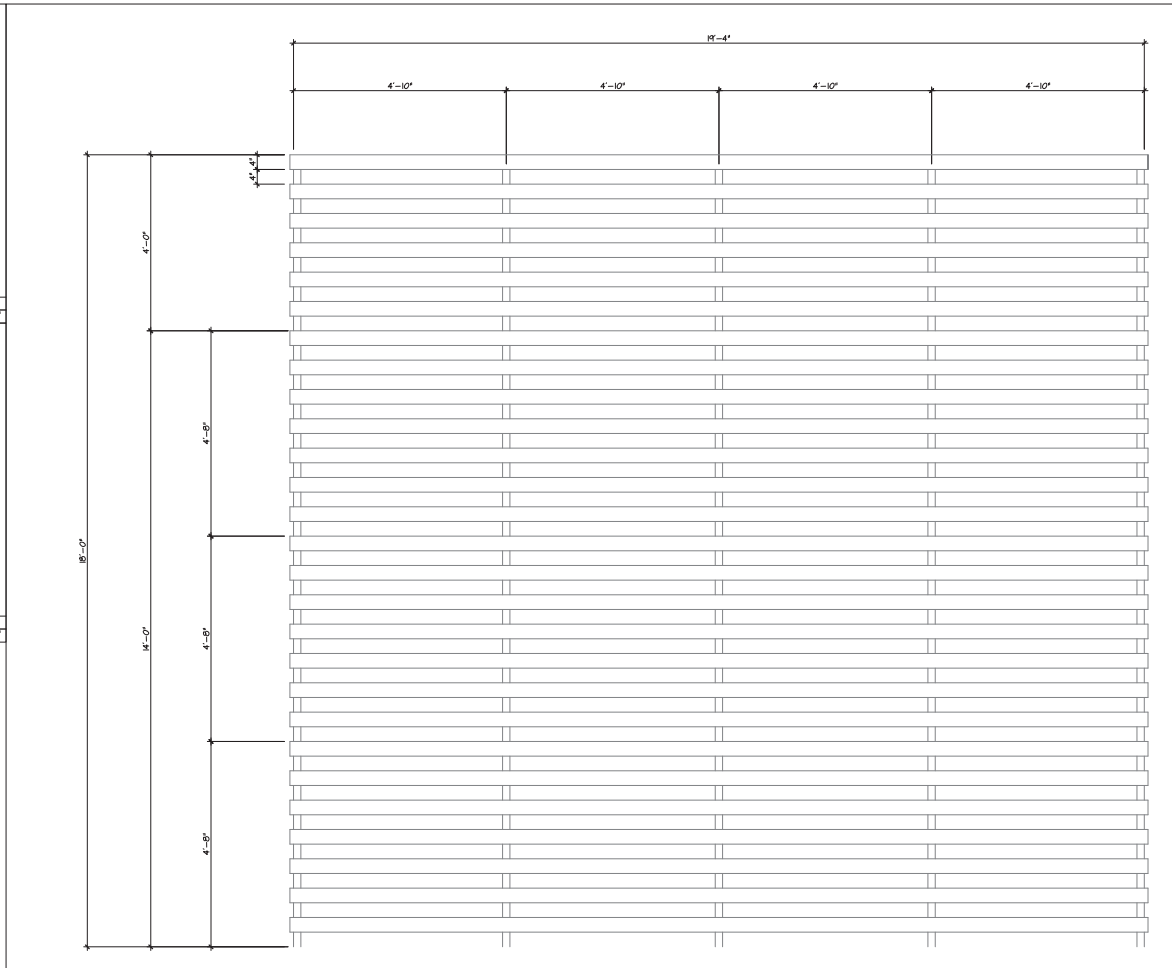
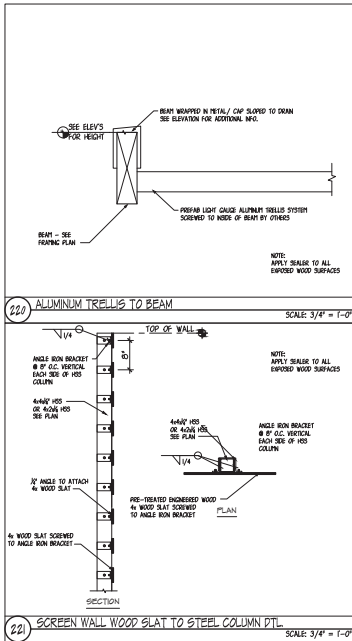

CONCEPTUAL RENDERING



**From:** [Karen Morrissey](#)  
**To:** [Kaminski, Diana](#)  
**Subject:** PL 230326  
**Date:** Sunday, December 3, 2023 6:53:31 PM  
**Attachments:** [PL230326.pptm](#)

---

Hello,

I'm not only the next door neighbor, to this proposal, I am also the neighborhood chair for our neighborhood, Wilson Art and Garden. Both the neighborhood and I would like to urge the denial of the use permit for 921 S Roosevelt for PL 230326. I have outlined my 5 points for denial in the attached PowerPoint that I will be using for my 3 minutes to defend my privacy and peace. While the PL # 230326 and design firm has changed, the issues remain dwelling for 4 years now.

This is what I sent to the neighborhood via email. I hope you get a lot of feedback:

Please can you consider submitting a public comment or attending in person to be heard about a proposed 300 foot "walk deck" overlooking both existing neighbors property at 921 S. Roosevelt St. This deck was originally proposed in 2019 and after 2 DRC meetings and 1 city council meeting, the "walk deck" narrowly passed, in favor of the developer. When attempts to work with Lewis's to build a structure that would conform to current Tempe building guidance, Lewis family indicated that they will not consider neighbors concerns and this deck was a "want", not a "need". Lewis's are also requesting less than 7 foot setback from neighbors property to build a large metal staircase leading to this deck, despite the room to have this staircase in their backyard.

Covid occurred in 2020 and despite numerous extensions, Lewis's did not build. Now that its 2023/2024, we have seen the issues arising from rental and Air BnB housing in our neighborhood.

**Would you like the liability of living next to a large party deck that is elevated 12 to 15 feet above your backyard?**

This property is 200 feet deep by 50 feet wide. We feel there is plenty of room on this property to build a nice house without intruding on neighbors privacy and peace, and urge you to comment publicly at the DRC on Tue Dec 12th at 6:00pm.

Thank you  
Karen Morrissey



[Sent from Yahoo Mail for iPhone](#)



PL 230326

921 S Roosevelt St Tempe 85281

Public comment to DRC by Karen Morrissey,  
property owner to the North @ 917 S. Roosevelt St

**VOTE NO USE PERMIT FOR 300 ft 2nd STORY DECK @ 921 S ROOSEVELT**

# Vote No for Use Permit for 2<sup>nd</sup> Story 300 ft walk deck / elevated outdoor living room



- ▶ While Neighbors welcome improvement to 921 s Roosevelt St.,
- ▶ Neighbors DO NOT welcome a 2<sup>nd</sup> story 300 foot deck overlooking backyards
  - ▶ PRIVACY ISSUE
  - ▶ 10,000 sq ft - Only 50 ft WIDE - 4500 sq feet of ground space left after new bldg
  - ▶ Not compatible w existing structures
  - ▶ Use Permit = asking for something more than Tempe citizens want
  - ▶ Owner does not care about neighbor concerns

**VOTE NO USE PERMIT FOR 300 ft 2nd STORY DECK @ 921 S ROOSEVELT**

# Use permits must have 5 points they need to satisfy. This property does not satisfy any of these points:

- ▶ **Increased vehicle or pedestrian traffic** - YES, deck will bring additional vehicles/foot traffic into the neighborhood for people attending these gatherings
- ▶ **Nuisance from emission of Gas, Odor, Noise, Vibration** - this deck will bring Noise and Vibration from the deck and stairs, along with Light pollution
- ▶ **Deterioration of the neighborhood** - Deck will open up the property to big gatherings. If the property changed hands, would be a desirable home for frat house or AirBnB.
- ▶ **Adequate control of disruptive behavior - Noise Ordinance issues**
- ▶ **Compatibility of existing structures** - despite the examples the contractor has provided of existing decks, All of these examples are not comparable:
  - ▶ Proposed deck is **only** accessible from the outside.
  - ▶ Deck is **much larger** than any other smaller decks in the surrounding neighborhood.
  - ▶ Proposed deck is in the **middle of the block**, all examples were properties of corner houses
  - ▶ All structures on 9<sup>th</sup> - 10<sup>th</sup> Street Roosevelt to Wilson are **SINGLE STORY homes with no decks**



**VOTE NO USE PERMIT FOR 300 ft 2nd STORY DECK @ 921 S ROOSEVELT**

# Why Deny?



- ▶ No Privacy
- ▶ Does not fit into immediate neighborhood character and design
- ▶ Entitlement / not Neighborly Feeling / Animosity from Owner
  - ▶ Deck is a WANT, not a NEED
  - ▶ Owner did not follow DRC recommendations in 2020 PL 190295 - did not attend any meetings w neighbors
- ▶ Variance in building requested by Lewis's from Tempe's current General Plan for land use

**VOTE NO USE PERMIT FOR 300 ft 2nd STORY DECK @ 921 S ROOSEVELT**

# Facts

- ▶ Owner never lived on property
- ▶ Owners Son might or might not live on property - rental property?
- ▶ Name on Use Permit request is from Contractor
  - ▶ Not the Owner
  - ▶ Contractor has no decision making power
- ▶ I have lived in Tempe since 1983 - owned /occupied house since 1996
- ▶ Neighbor to South has lived at property close to 50 years
- ▶ Temporary walls or 8 inches of cinderblock increase in height on ground level will not block out light, vibration, noise from deck that starts @12 ft in height



**VOTE NO USE PERMIT FOR 300 ft 2nd STORY DECK @ 921 S ROOSEVELT**

# Support **AGAINST** Use Permit by all surrounding Neighbors along with Neighborhood Association Chairpersons



- ▶ Wilson Garden
- ▶ Maple Ash
- ▶ Mitchell Park
- ▶ Riverside
- ▶ Sunset
- ▶ Emails from concerned neighbors
- ▶ This sets a precedence for party decks in our neighborhood

**VOTE NO USE PERMIT FOR 300 ft 2nd STORY DECK @ 921 S ROOSEVELT**

# History - Issue has been pending since 2019 - PL 1903295 DRC Chairman D. Lyons deviation from process - JAN 14<sup>th</sup> , 2020 Initial DRC meeting



- ▶ 6 out of the 7 committee members leaning towards a “NO” vote but DRC Chairman Lyon’s offered the Owner/Contractor a continuance, asking to get with the neighbors to communicate
- ▶ All DRC committee members express concern over this deck, except for Chairman Lyon’s who expressed his joy about climbing on the roof of his rental house in college
- ▶ Chairman Lyons took it upon himself to offer 2<sup>nd</sup> chance at DRC - **Does City of Tempe offer “2<sup>nd</sup> chance” for every property developer?**
- ▶ Mr. Lyons wrong idea about neighborhood
  - ▶ No Privacy already?
  - ▶ Immediate neighborhood is owner occupied not college rentals
  - ▶ Our homes are not TEAR DOWN
  - ▶ GENERAL PLAN 2040 CULTURAL RESOURCES AREA

VOTE NO USE PERMIT FOR 300 ft 2nd STORY DECK @ 921 S ROOSEVELT



# More History on PL 190295 Feb 3<sup>rd</sup> , 2020

## Discussing the plan

- ▶ Kathy Palmer (Neighbor) initiated meeting to voice concerns about proposed deck
- ▶ Karen Morrissey didn't attend this meeting due to work and family responsibilities
- ▶ Ms. Palmer suggested:
  - ▶ Smaller deck - less than 270 sq. feet , or
  - ▶ Smaller balcony on back of the new bldg., or
  - ▶ Deck in a different area to be less intrusive, or
  - ▶ Staircase on the back of house, or
  - ▶ Spiral staircase on back on house, or
  - ▶ No deck
  - ▶ Finish out the building with a 2<sup>nd</sup> story
- ▶ Owner did not attend meeting
  - ▶ Owner's son and Developer did not have any decision making capability
- ▶ Owner not receptive to any of these suggestions



# History of PL 190295 - DRC Meeting Feb 11<sup>th</sup>, 2020



- ▶ DRC voted 4-2 in favor of the USE PERMIT
- ▶ 2 different board members were present than first DRC meeting
- ▶ Owner and Developer did not satisfy DRC request to meet with neighbors to come up w optimal solution
- ▶ Owner has not been forthcoming with information during the entire process

**VOTE NO USE PERMIT FOR 300 ft 2nd STORY DECK @ 921 S ROOSEVELT**

# History of PL 190295 Feb 21<sup>st</sup> , 2020 - Another Meeting



- ▶ Kathy Palmer and Karen Morrissey met with Contractor for LEWIS's along with Robbie Aaron and Ryan Levesque from the City of Tempe Planning Dept to propose solutions
  - ▶ Owner did not attend this meeting or call into meeting
  - ▶ This was an effort to avoid the petition to go to City Council over the USE PERMIT for the deck
  - ▶ The Contractor responded to Neighbors on 2/24
    - ▶ Would not change anything
    - ▶ Not the decision maker
    - ▶ Used CONCRETE NETWORK.COM as a baseline to come up w 270 foot deck. But CONCRETE NETWORK.COM recommended this size for a ground patio, not one that is 12 feet in the air. Contractor misunderstood this fact.
  - ▶ Same large size, along with same design from 2<sup>nd</sup> hearing, no neighborhood input was accepted

**VOTE NO USE PERMIT FOR 300 ft 2nd STORY DECK @ 921 S ROOSEVELT**

# History of PL 190295 - City Council Presentation and Vote - April 2020

- ▶ City Council voted - narrow decision of 4-3 in favor of the developer
- ▶ Due to Covid, Lewis's received many continues to build but never did build, property has sat vacant for 4 years
- ▶ New applicant - MNF Design but same issues exist
- ▶ Its 4 years later and we have experienced the worse of what Air BnB's and rental home parties can bring. I am afraid of having many people on an elevated deck partying as it can bring trouble and shootings. It makes me scared.
- ▶ Please vote No on PL 230326

**VOTE NO USE PERMIT FOR 300 ft 2nd STORY DECK @ 921 S ROOSEVELT**

