



**CITY OF TEMPE
DEVELOPMENT REVIEW COMMISSION**

**Meeting Date: 1/8/2019
Agenda Item: 3**

ACTION: Request a Use Permit to allow a second story for a single-family residence rebuild, and a Use Permit Standard to reduce the required south side building setback from 10 feet to 8 feet for the **SKINNER RESIDENCE**, located at 919 South Maple Avenue. The applicant is JCL Design/Build, LLC.

FISCAL IMPACT: N/A

RECOMMENDATION: Staff – Approve, subject to conditions

BACKGROUND INFORMATION: The SKINNER RESIDENCE (PL180344) is proposed on Lot 6 of the Gage Addition subdivision, located on the east side of South Maple Avenue between West 10th and 9th Street in the R-3, Multi-Family Residential District. The project consists of a new two-story single-family residence with a basement, and a rear-facing detached two-car garage. The Use Permit Standard is requested for the main house; the detached garage conforms to setback requirements for accessory buildings. The request includes the following:

- ZUP180111 Use Permit Standard to reduce the south side building setback from 10 feet to 8 feet.
- ZUP180112 Use Permit to allow a single story single-family residence to rebuild with a second story.

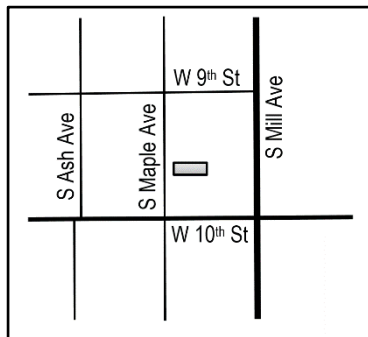

Property Owner	Tad and Katina Skinner
Applicant	Jared Lineberger, JCL Design/Build, LLC
Zoning District	R-3
Site Area	7,000 s.f. (0.16 acres)
Total Bedrooms	6
Total Bathrooms	5.25
Building Area	4,314 s.f.
Lot Coverage	39% (50% max. required)
Building Setbacks	22' front (building), 15' front (open structure), 10' north side, 8' south side, 55' rear, 8' balcony north side (20', 15', 10', 10', 15', 5' min. required)
Building Height	25'-0"
Accessory Building Setbacks	6' north side, 22' south side, 14' rear (6', 6', 6' min. required)
Accessory Building Height	11'-6"
Vehicle Parking	3 spaces (2 min. required)

ATTACHMENTS: Development Project File

STAFF CONTACT(S): Lee Jimenez, Senior Planner (480) 350-8486

Department Director: Chad Weaver, Community Development Director
Legal review by: N/A
Prepared by: Lee Jimenez, Senior Planner
Reviewed by: Steve Abrahamson, Principal Planner

COMMENTS

The ground and basement floors combine to provide a kitchen, four bedrooms, three-and-a-quarter bathrooms, and a living, dining, great, game, and laundry room. The second story consists of a casita with two bedrooms, two bathrooms, a kitchen, a great room, and a laundry room. A separate side entrance to the internal stairwell leading to the second story is provided on the west end of the south elevation; otherwise, access to the second-floor stairwell from the ground level is provided through a guest bedroom. Overall, the house provides a total of 6 bedrooms and five-and-a-quarter bathrooms. The existing driveway from South Maple Avenue along the north edge of the property will be upgraded with a ribbon driveway and provide approximately two (2) additional off-street parking spaces.

PUBLIC INPUT

- Neighborhood meeting required:
 - Meeting held: December 6, 2018 from 5 p.m. to 6 p.m. at 919 South Maple Avenue.
 - See attached summary of meeting provided by the applicant.
 - During the neighborhood meeting process, and prior to the formal application submittal, the following responses were received by the applicant:
 - Email in support from Steve Tseffos as an individual and owner of multiple properties in the area, and on behalf of M.A.P.L.E. (Maple Ash Property Landowners Entity), an affiliate.
 - Mailed response in support from the property owner of 1005 and 1111 South Maple Avenue.
 - Community Development staff attended the meeting.
- To date, no public input has been received by staff during the legal advertisement of the public hearing requests.

ZUP180111

USE PERMIT STANDARD

The proposed design requires a Use Permit Standard to reduce the south side building setback by two feet from 10 feet to 8 feet within the R-3, Multi-Family Residential District.

Section 6-308 E Approval criteria for Use Permit (*in italics*):

1. *Any significant increase in vehicular or pedestrian traffic*; although the setback reduction increases the building area, the use of the increased area is intended for a single-family use and is not expected to significantly increase vehicular or pedestrian traffic. The two (2) required off-street parking spaces will be provided within a detached garage with access from the alley, and two (2) additional off-street spaces will be located within the front driveway along the north edge of the property.
2. *Nuisance arising from the emission of odor, dust, gas, noise, vibration, smoke, heat or glare at a level exceeding that of ambient conditions*; the owner intends to maintain a single-family use on the property which is not expected to generate emissions exceeding ambient conditions that would otherwise cause a nuisance.
3. *Contribution to the deterioration of the neighborhood or to the downgrading of property values, which is in conflict with the goals, objectives or policies for rehabilitation, redevelopment or conservation as set forth in the city's adopted plans or General Plan*; the setback reduction will provide additional living space and is expected to add value to not only the property itself but the surrounding neighborhood as well.
4. *Compatibility with existing surrounding structures and uses*; the single-family use to the south at 929 South Maple Avenue benefits from a similar side building setback reduction along the same property line that the SKINNER RESIDECE is seeking relief from.
5. *Adequate control of disruptive behavior both inside and outside the premises which may create a nuisance to the surrounding area or general public*; the additional living space provided as a result of the setback reduction will continue as a single-family use which is not expected to cause any disruptive behavior.

**ZUP180112
USE PERMIT**

The proposed design and use require a Use Permit to allow a rebuild of a single story single-family residence with a second story within the R-3, Multi-Family Residential District.

Section 6-308 E Approval criteria for Use Permit (*in italics*):

1. *Any significant increase in vehicular or pedestrian traffic*; the proposed second-story use is not expected to increase vehicular or pedestrian traffic more than what is expected from a single-family use which is the intent of this application.
2. *Nuisance arising from the emission of odor, dust, gas, noise, vibration, smoke, heat or glare at a level exceeding that of ambient conditions*; the proposed second-story use is intended for a single-family use and will not generate emissions greater than ambient conditions that would otherwise cause a nuisance to the neighborhood.
3. *Contribution to the deterioration of the neighborhood or to the downgrading of property values, which is in conflict with the goals, objectives or policies for rehabilitation, redevelopment or conservation as set forth in the city's adopted plans or General Plan*; the proposed second-story use will allow for additional living space which is expected to add value to the property as well as other properties in the neighborhood.
4. *Compatibility with existing surrounding structures and uses*; the area of most disturbance to this Use Permit request is the neighboring property to the south; however, the south elevation does not provide any large windows or balconies on the second story. On the other hand, the north elevation of the home provides large windows on the second story, including a balcony with arcadia doors, but the neighboring parcel to the north is a vacant parcel of a two-parcel historic property where the home itself is sits on the northern parcel. Furthermore, a second-story use currently exists on a single-family use property located two lots to the south at 923 South Maple Avenue.
5. *Adequate control of disruptive behavior both inside and outside the premises which may create a nuisance to the surrounding area or general public*; the second-story use is intended for a single-family use and is not expected to cause any disruptive behavior.

REASONS FOR APPROVAL:

Based on the information provided by the applicant, the public input received, and the above analysis staff supports approval of the requested Use Permit Standard (ZUP180111) and Use Permit Standard (ZUP180112). The requests meet the required criteria and will conform to the conditions.

SHOULD AN AFFIRMATIVE ACTION BE TAKEN ON THIS REQUEST, THE FOLLOWING NUMBERED CONDITIONS OF APPROVAL SHALL APPLY, BUT MAY BE AMENDED BY THE DECISION-MAKING BODY.

ZUP180111

USE PERMIT STANDARD CONDITIONS OF APPROVAL:

1. The Use Permit Standard is valid only after a Building Permit has been obtained and the required inspections have been completed and a Final Inspection has been passed. As part of the Building Permit process, on-site storm water retention may be required to be verified or accomplished on this Site.
2. The Use Permit Standard is valid for the plans as submitted within this application. Any additions or modifications may be submitted for review during building plan check process.
3. Remove the separate side entrance on the west end of the south elevation.
4. Reorient the interior stairwell to provide access to the second story from the main living area of the ground level.

5. Provide a minimum setback distance of sixteen feet (16'-0") between the rear property line and the detached garage to prevent parked vehicles from blocking the public alley.
6. Any future additions encroaching within the required south side building setback shall require a new Use Permit Standard.

ZUP180112

USE PERMIT CONDITIONS OF APPROVAL:

1. The Use Permit is valid only after a Building Permit has been obtained and the required inspections have been completed and a Final Inspection has been passed. As part of the Building Permit process, on-site storm water retention may be required to be verified or accomplished on this Site.
2. The Use Permit is valid for the plans as submitted within this application. Any additions or modifications may be submitted for review during building plan check process.
3. Remove the separate side entrance on the west end of the south elevation.
4. Reorient the interior stairwell to provide access to the second story from the main living area of the ground level.
5. Provide a minimum setback distance of sixteen feet (16'-0") between the rear property line and the detached garage to prevent parked vehicles from blocking the public alley.
6. Any future second story additions shall require a new Use Permit.

CODE/ORDINANCE REQUIREMENTS:

THE BULLETED ITEMS REFER TO EXISTING CODE OR ORDINANCES THAT PLANNING STAFF OBSERVES ARE PERTINENT TO THIS CASE. THE BULLET ITEMS ARE INCLUDED TO ALERT THE DESIGN TEAM AND ASSIST IN OBTAINING A BUILDING PERMIT AND ARE NOT AN EXHAUSTIVE LIST.

- Specific requirements of the **Zoning and Development Code (ZDC)** are not listed as a condition of approval, but will apply to any application. To avoid unnecessary review time and reduce the potential for multiple plan check submittals, become familiar with the ZDC. Access the ZDC through <http://www.tempe.gov/zoning> or purchase from Development Services.

HISTORY & FACTS:

None pertinent to the subject requests.

ZONING AND DEVELOPMENT CODE REFERENCE:

Section 3-102 Permitted Uses in Residential Districts
Section 3-420 Single-Family Residential Second Story Addition or Rebuild
Section 4-201A Use Permit Standard
Section 4-202 Development Standards for Residential Districts
Section 6-308 Use Permit

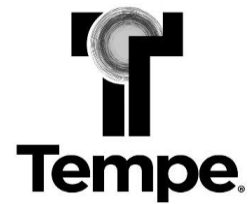

DEVELOPMENT PROJECT FILE
for
SKINNER RESIDENCE
(PL180344)

ATTACHMENTS:

1. Location Map
2. Aerial
- 3-5. Letter of Explanation
6. Site Plan
- 7-9. Floor Plan
10. Building Elevations
11. Accessory Building Floor Plan and Building Elevations
- 12-18. Neighborhood Meeting Summary *(if required)*
- 19-20. Site Context Photos

Skinner Residence

PL180344

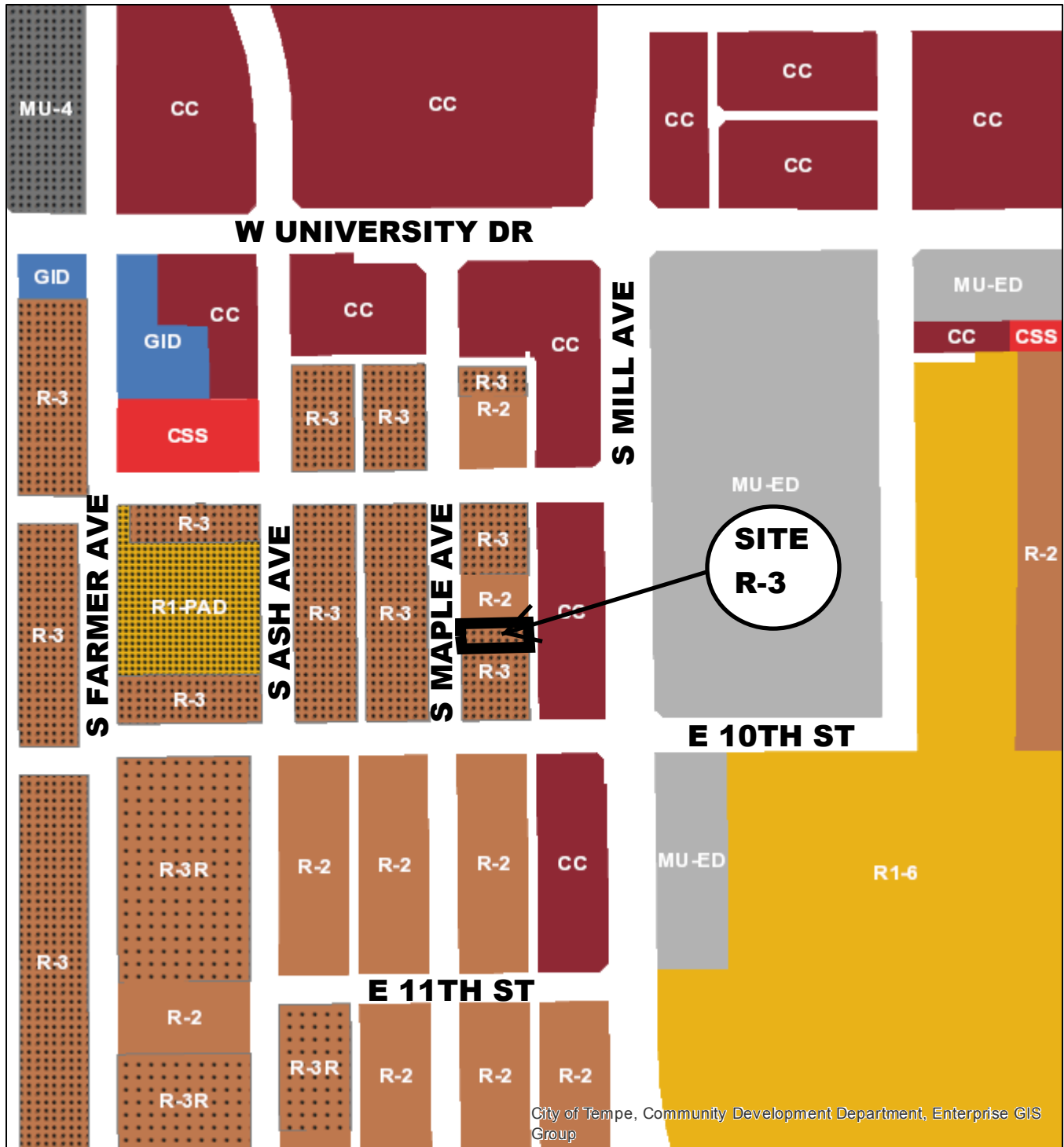

City of Tempe, Community Development Department, Enterprise GIS Group

- | | |
|--|---|
| General Industrial District (GID) | Single-Family Residential (R1-6) |
| City Center (CC) | Single-Family Residential Planned Area Dev (R1-PAD) |
| Mixed Use High (MU-4) | Multi-Family Residential (R-2) |
| Mixed Use Educational (MU-ED) | Multi-Family Residential Restricted (R-3R) |
| Commercial Shopping and Services (CSS) | Multi-Family Residential Limited (R-3) |

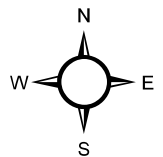

Skinner Residence

PL180344



Aerial Map

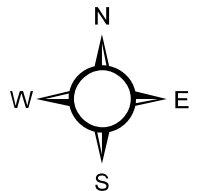

Letter of Explanation
Skinner Residential Home
919 S. Maple Ave. (9th Street and Maple Avenue)

The Skinner Residence will be a single family home, and used for the primary residence for the Skinner Family.

We (Tad and Katina Skinner) chose this neighborhood for a number of reasons. Primarily, Tad has worked at a church in downtown Tempe for 20 years and we want to live closer to the church. We have lived in Tempe (south of US 60) for 15 years and the traffic to and from our church and his work have progressively worsened as ASU has grown. We are excited to soon be minutes from this significant part of our lives.

We will move our family of four people into this home. The house has been designed to fit our family and our life style. We frequently have groups of friends over for a meal and discussion time after dinner. We like to have a separation of adults and children after the meal so that the adults can hear each other talk and the children can play freely. For this reason we have designed the house with two living areas on the main floor and one in the basement. We also desire a spare bedroom with a full bathroom on the main floor for visitors who might like privacy and/or not have to climb the stairs.

In order to have a small backyard, we designed the house to be two feet wider than what the current setbacks allow and with two stories and a basement. This design allows us to maximize the living space while keeping the footprint smaller and more in line with the existing neighborhood. Compared to what is currently on the property (garage on the property line) and other houses in the neighborhood we did not think this would be a problem.

The family bedrooms and laundry room will be in the basement, as will a game room that will contain our treadmill, a television, and (if it fits) a ping pong table or pool table.

City of Tempe Questions Use permit for 20% set back reduction:

- a. ***Any significant vehicular or pedestrian traffic in adjacent areas;***
- b. ***Nuisance arising from the emission of odor, dust, gas, noise, vibration, smoke, heat or glare at a level exceeding that of ambient conditions;***
- c. ***Contribution to the deterioration of the neighborhood or to the downgrading of property values, which is conflict with the goals, objectives or policies of the city's adopted plans for General Plan;***
- d. ***Compatibility with existing surrounding structures and uses; and***
- e. ***Adequate control of disruptive behavior both inside and outside the premises, which***

Our response:

- a. There will be no significant vehicular or pedestrian traffic for this proposed use permit as it is for a single family home
- b. There will be no significant emissions of any kind as it will be a single family home used for owner occupied use.
- c. We believe that this use permit will allow for a significant added value to the neighborhood and will help to revitalize the area for many generations to come.
- d. The proposed dwelling is designed in such a way as to keep the street scape intact. We believe that by using a mid-century prairie style design, it fits quite nicely with the surrounding structures and into the fabric of the street scape.
- e. As it will be a single family home, there will be no significant disruptive behavior to the neighborhood.

The house is designed with a second story, two bedroom guest suite. We anticipate that at least one, but likely both, of our two children will attend ASU in the next 2-4 years. We would like to provide housing for them that will be affordable for us, but also give them a measure of privacy and independence. Once the need to house our children has passed, we plan to use the guest suite for visiting family, church friends, and church missionaries. Part of the ministry philosophy of our church is to provide temporary housing for church staff and missionaries to the ASU campus until they are able to find permanent, affordable housing. We expect to participate in this by inviting missionaries on staff with our church (our friends) to live with us, but as stated before, with a measure of privacy and independence. The guest suite has a balcony so that its residents can sit outside without always coming down to sit with us. The guest suite does in fact overlook the property to the north; however, the property is a historic home and sits on two lots with the lot directly adjacent to ours having no residence on it. The lot directly adjacent has substantial vegetation that nearly completely shields the residence from our property. Therefore, we believe this should not pose any privacy issues to the resident of that property. Furthermore, that property is owned and managed by the Maple-Ash group and is currently a rental property.

The guest suite is meant to provide housing for our children and/or friends, so that we (Tad and Katina) are available and close, but they don't have to share their kitchen and all their downtime with us. We do not intend to make money by renting the guest suite.

City of Tempe Questions use permit for second story

- f. Any significant vehicular or pedestrian traffic in adjacent areas;**
- g. Nuisance arising from the emission of odor, dust, gas, noise, vibration, smoke, heat or glare at a level exceeding that of ambient conditions;**

- h. Contribution to the deterioration of the neighborhood or to the downgrading of property values, which is conflict with the goals, objectives or policies of the city's adopted plans for General Plan;**
- i. Compatibility with existing surrounding structures and uses; and**
- j. Adequate control of disruptive behavior both inside and outside the premises, which**

Our response:

- f. There will be no significant vehicular or pedestrian traffic for this proposed use permit as it is for a single family home
- g. There will be no significant emissions of any kind as it will be a single family home used for owner occupied use.
- h. We believe that this use permit will allow for a significant added value to the neighborhood and will help to revitalize the area for many generations to come.
- i. The proposed dwelling is designed in such a way as to keep the street scape intact. We believe that by using a mid-century prairie style design, it fits quite nicely with the surrounding structures and into the fabric of the street scape.
- j. As it will be a single family home, there will be no significant disruptive behavior to the neighborhood.

Sincerely,

Handwritten signatures of Tad and Katina Skinner. The signature for Tad is on the left and for Katina is on the right.

Tad and Katina Skinner

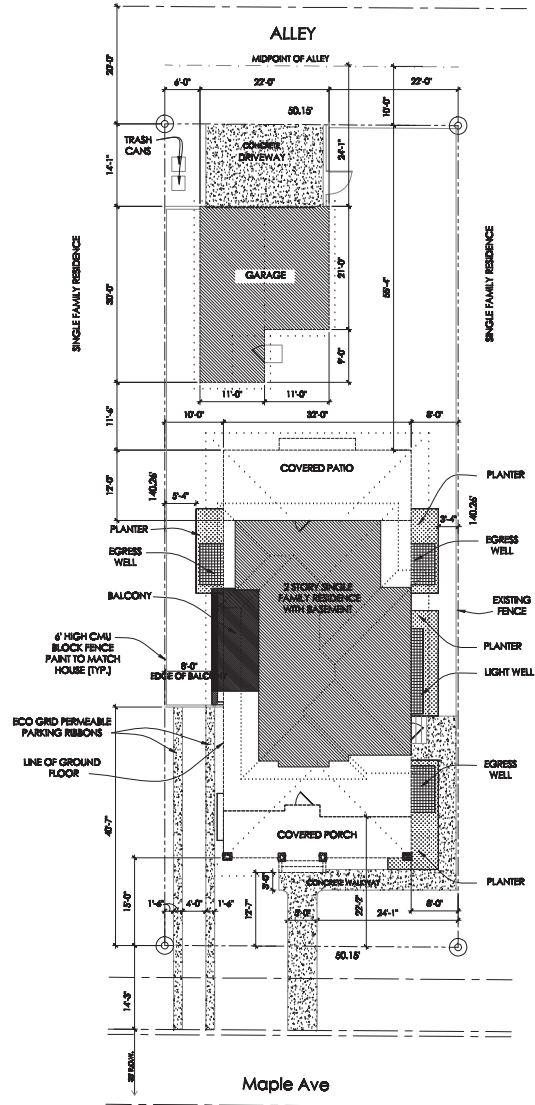

Site Plan
1" = 10'
0' 5' 10' 20'

General Builder's Notes

- All work shall comply with all applicable codes and ordinances.
- The Contractor shall verify all dimensions and conditions in the field. If a dimensional error occurs or a condition not covered in the drawings is encountered, the Contractor shall notify the architect before commencing that portion of the work.
- The Contractor shall notify the architect if discrepancies are noted in these Contract Documents, in sufficient time as to not cause delay.
- Dimensions take precedence over scale on the Construction Documents.
- Details, notes, and finishes shall be applicable to all typical conditions whether or not referenced at all places on these plans.
- The Contractor shall verify all existing grades and shall review all grading conditions prior to commencement of work.
- The Contractor shall take all necessary precautionary measures to protect the public and adjacent properties from damage throughout construction.
- The Contractor shall verify all equipment loads and notify the architect of any changes in size, weight, and location, or additional load to those indicated on the drawings.
- The Contractor shall supervise and direct the work, using the best skill and attention. He shall be solely responsible for all methods, techniques, sequences, and procedures, and for coordinating all portions of the work under the contract.
- All manufactured articles, material, and equipment shall be applied, installed, connected, erected, used, cleaned, and conditioned in accordance with the manufacturer's written specifications or instructions unless hereinafter specified to the contrary.
- The Contractor shall verify the location of existing utilities and protect them.
- The starting of work by any contractor or subcontractor shall be considered prima facie evidence that he has inspected and accepted all conditions involved in his work and finds them satisfactory.
- The Contractor shall be responsible for safety in the area of work in accordance with all applicable safety codes.
- Each Contractor is responsible for any damage to adjacent work and is responsible for the repair and solid damage of his own expense.
- These drawings are for permit only. The Contractor is responsible for any standard or special detailing not specified herein.

PLEASE NOTE: OUTDOOR LIGHTING TO COMPLY WITH DARK SKY ORDINANCE.

Governing Building Codes

All construction shall comply with the following codes and Maricopa County amendments:

- 2012 International Building Code
- 2012 International Mechanical Code
- 2011 International Electrical Code
- 2012 International Fire Code
- 2012 International Plumbing Code
- 2012 National Fire Code

Energy Note:

2012 IECC - New and/or remodeled building envelope areas shall comply with the following: Penetration = U=0 max U-Factor, 0.25 max R-Value. Min. R-13 @ frame walls & floors, R-6 @ Mass wall, R-38 @ ceilings. Duct insulation located outside the building envelope requires minimum R-8 and R-4 when located in floor joists. Minimize air leakage per IECC402.4.

Special Notes

- The area around the structure must be graded to drain 4-inches down for the first 10-feet from the structure.

Vicinity Map N.T.S.

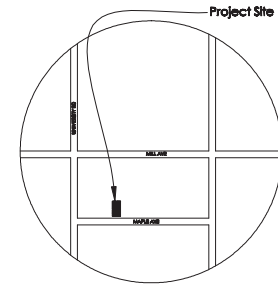

Project Directory

OWNER:
Todd and Katrina Skinner
1122 S. Code de Arco
Tempe, AZ, 85284
480.363.8888

DESIGNER:
JCL Design/Build
4333 S. Lakeshore dr.
Tempe, AZ, 85282
480.734.0294
solidrock15@yahoo.com

Project Data

PROJECT DESCRIPTION:
Single Family Residence, New Build.

PROPERTY ADDRESS:
919 S MAPLE AVE, Tempe, AZ 85281

PARCEL NUMBER: 132-02-041

ZONING:
R3

OCCUPANCY TYPE:
R-3 Single Family Residential

CONSTRUCTION TYPE:
V-8

BUILDING SIZE:

Ground floor -	1592 sf
Garage -	561 sf
Front Porch -	384 sf
Back Porches -	246 sf
Basement -	1829 sf

Total Footprint - with detached garage: 2768 sf

apt deck: 1042 sf
129 sf

total overall: 4314 sf

LOT SIZE: .16 acres 7000 sf

% COVERAGE: 39%

BUILDING SETBACKS:

Front	Required 20'-0"
Side	10'-0", 10'-0"
Rear	15'-0"

BUILDING HEIGHT:

Main house: 25'-0" above finished grade
Garage: 11'-0" above finished grade

Note:

All existing structures on lot to be demolished.

JCL design build

7436 S Juniper St.
Tempe, Arizona 85283
solidrock15@yahoo.com

This drawing is the property of JCL design/build and is limited to the original use for which it was prepared. Change, reproduction, or copying in any third party of this drawing for any other use is not permitted without written consent of JCL design/build.

Single Family Residence
Skinner Residence
Tempe

Date: 11.16.16



S
Site Plan

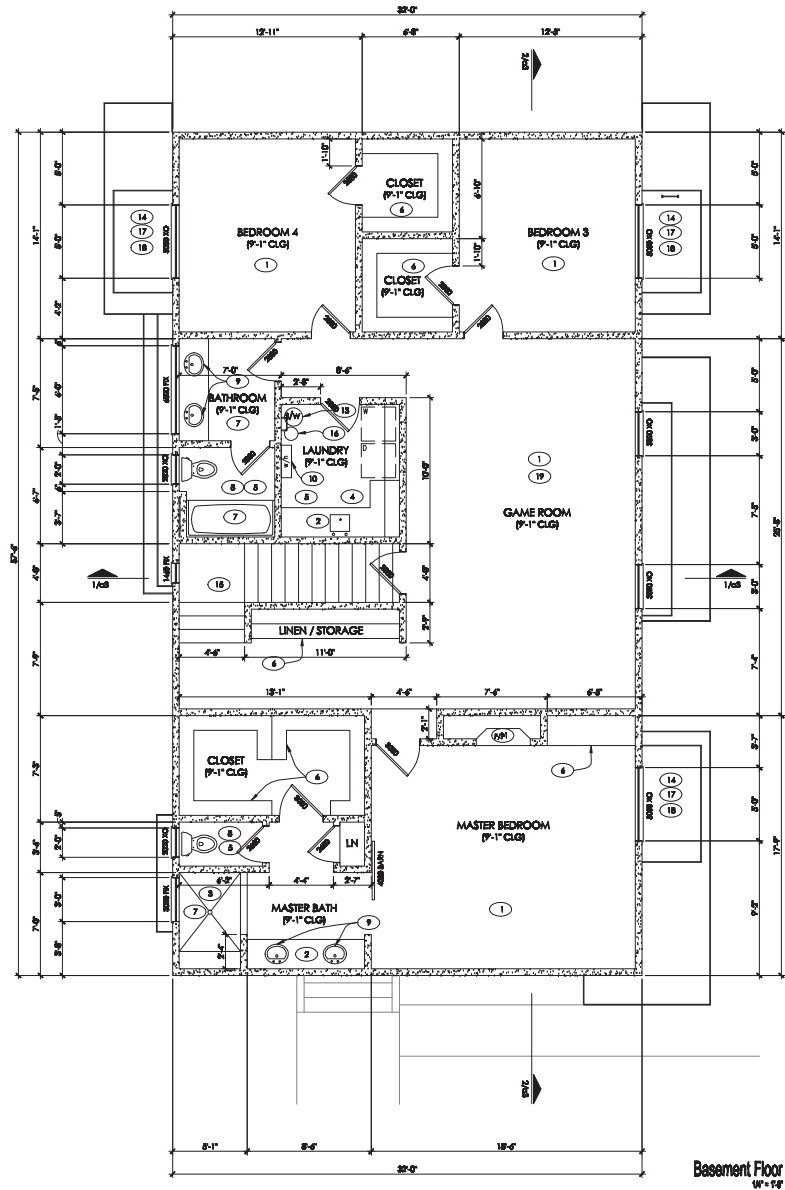

Basement Floor
WF-14

Keynotes

1. 4" Concrete slab.
2. Casework & counters to be designed & selected by Owner.
3. Non-slip/abrasion floor and wall tile at showers. 6'-0" above floor per R307.2, to be selected by Owner, over fiber cement board.
4. Provide washer box with waste drain, hot and cold water. Washer to be located to left of the dryer. Owner to select equipment.
5. Provide venting to outside wall with a minimum 4" diameter. Minimum 80 CFM required. Exhaust duct not to exceed 25 ft in length; max. length is reduced by 2.5 ft for each 45° bend and 6 ft for each 90° bend. See M1801. Owner to select equipment.
6. Shelving to be chosen by owner.
7. Tub and shower fixtures to meet low water use requirements, and to be selected by Owner.
8. Water closet to meet low water use requirements, and to be selected by Owner.
9. Sink and faucet to be selected by Owner.
10. Gas water heater with self-closing temperature/pressure relief valve drain to exterior. Terminate in a downward position 4" min and 2'-0" max above finish grade. Drain line to be galvanized steel, hard drawn copper, or CPVC/PB (with fittings not to reduce internal bore of pipe or straight line tubing). Valve shall not be used to control thermal expansion.
11. Fire place.
12. Mechanical system to be sized and selected by General Contractor.
13. Water softener.
14. Egress Well.
15. Stairs to Ground Floor.
16. Sump pump.
17. Window well ladder to be permanently fixed to well wall and to conform to section 310.2.2.
18. Escape wells shall be a min. of 9" x 9" connected to foundation drainage system and shall comply with all code requirements in section 310. (Window well to be stiff back, 2 egress well or equivalent.)
19. All wall coverings shall conform to section 702.4
20. Provide 1/4" C.W. line in refrigerator space. Owner to select equipment.

Special Notes

1. At all out-swinging doors, provide landing not lower than 4" below top of door threshold, per R311.4.3 amended.
2. Truss calculations to be provided to inspector on site.
3. Stairs to basement shall comply with all applicable code requirements per section R311 and R312

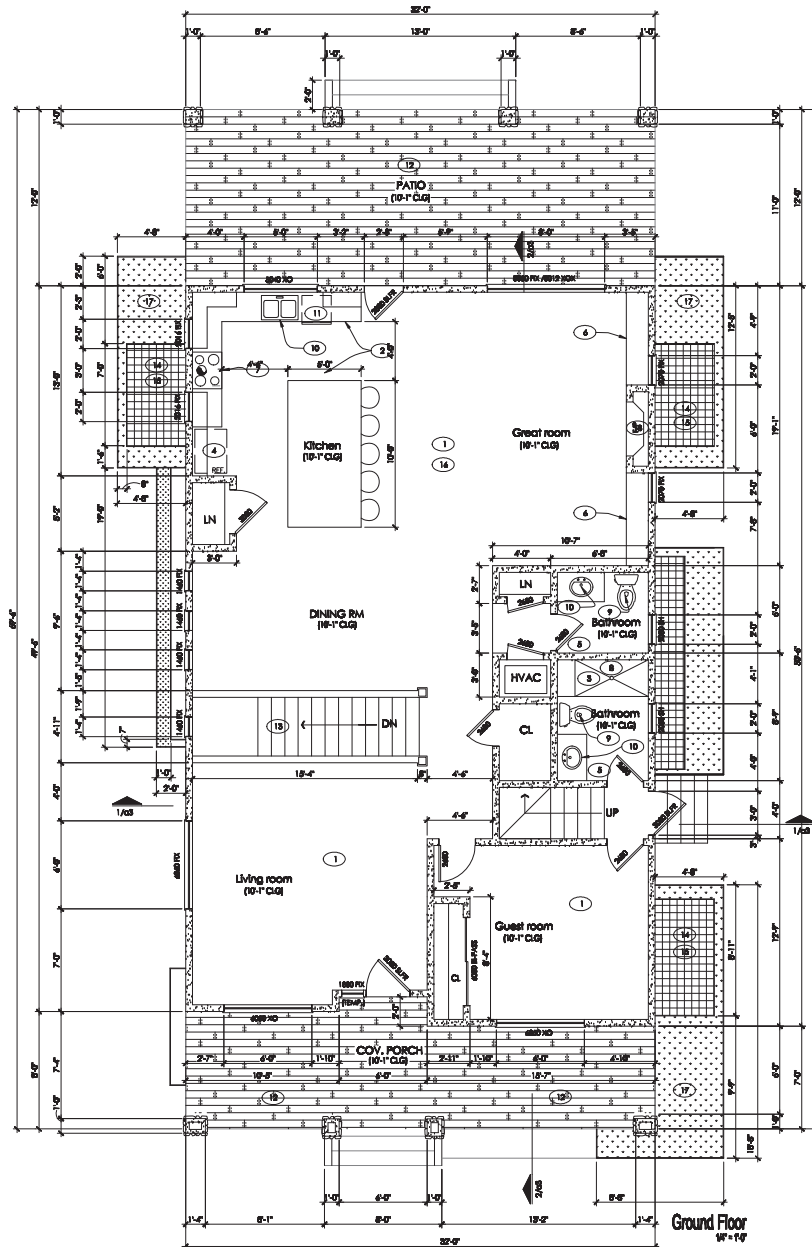

Keynotes

1. Wood floor.
2. Casework & counters to be designed & selected by Owner.
3. Non-slab-on-floor and wall tile at showers. 6'-0\"/>

Special Notes

1. At all out-swinging doors, provide landing not lower than 4\"/>

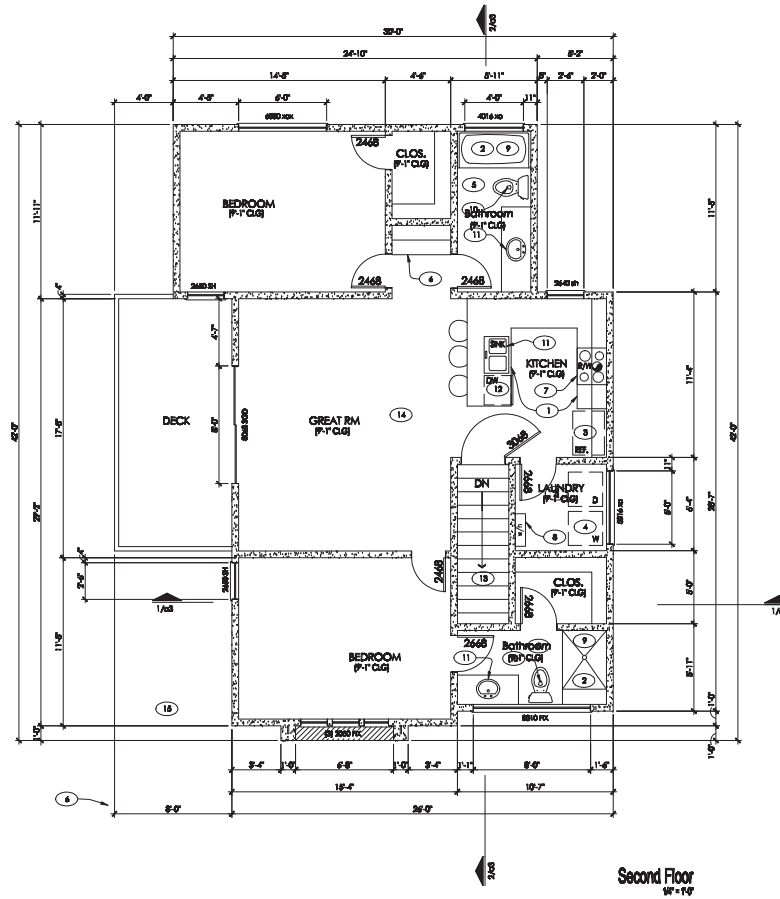

Keynotes

1. Casework & counters to be designed & selected by Owner.
2. Non-abrasant floor and wall tile at showers, 6'-0" above floor per R307.2, to be selected by Owner.
3. Provide 1/4" c.w. line in refrigerator space. Owner to select equipment.
4. Provide washer box with waste drain, hot and cold water. Washer to be located to left of the dryer. Owner to select equipment.
5. Provide venting to outside wall with a minimum 4" diameter. Minimum 80 CFM required. Exhaust duct not to exceed 28 ft in length; max. length is reduced by 2.5 ft for each 45° bend and 8 ft for each 90° bend. See M1801. Owner to select equipment.
6. Shelving to be chosen by owner.
7. Sec. range with hood & exhaust fan vented through roof.
8. Sec. water heater with self-closing temperature/pressure relief valve drain to exterior. Terminate in a downward position 6" min and 2'-0" max above drain grade. Drain line to be galvanized steel, hard drawn copper, or CPVC (P) with fittings not to reduce internal bore of pipe or straight line tubing. Valve shall not be used to control thermal expansion.
9. Tub and shower fixtures to meet low water use requirements, and to be selected by Owner.
10. Water closet to meet low water use requirements, and to be selected by Owner.
11. Sink and faucet to be selected by Owner.
12. Provide drain line and water supply for dishwasher.
13. Stairs to First Floor.
14. All wall coverings shall conform to section 702.4

Special Notes

1. At all out-swinging doors, provide landing not lower than 4" below top of door threshold, per R311.4.3 amended.
2. Truss calculations to be provided to inspector on site.
3. Stairs to basement shall comply with all applicable code requirements per section R311 and R312

Attic Ventilation Calculations

LIVABLE ROOF AREA - 2920 SQ.FT. HIGH/LOW VENTING @ 1/300

REQUIRED AREA:
 2920 SQ.FT. / 300 = 9.73 SQ.FT. X 144 = **1402 SQ.IN.**
 80% HIGH - 701 SQ.IN. 80% LOW - 701 SQ.IN.

PROVIDED:
 HIGH: 74 LIN.FT. OF RIGID ROLL PLUS @ 13 SQ.IN. PER LIN.FT. = 962 SQ.IN.
 LOW: (18) 3 1/2" X 22 1/2" SCREENED BAYE VENTS @ 37 SQ.IN. = 702 SQ.IN.

TOTAL PROVIDED: 1664 SQ.IN.

GARAGE ROOF AREA - 926 SQ.FT. HIGH/LOW VENTING @ 1/300

REQUIRED AREA:
 926 SQ.FT. / 300 = 3.09 SQ.FT. X 144 = **445 SQ.IN.**
 80% HIGH - 229 SQ.IN. 80% LOW - 229 SQ.IN.

PROVIDED:
 HIGH: 27 LIN.FT. OF RIGID ROLL PLUS @ 13 SQ.IN. PER LIN.FT. = 351 SQ.IN.
 LOW: (4) 3 1/2" X 22 1/2" SCREENED BAYE VENTS @ 37 SQ.IN. = 294 SQ.IN.

TOTAL PROVIDED: 645 SQ.IN.

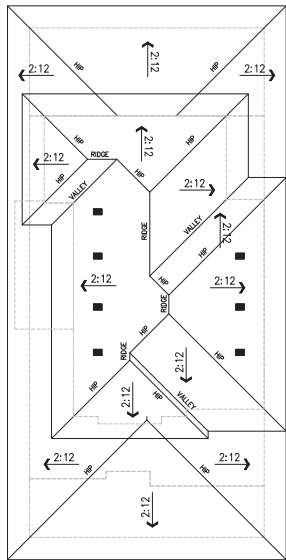

Roof Plan
18' x 14'

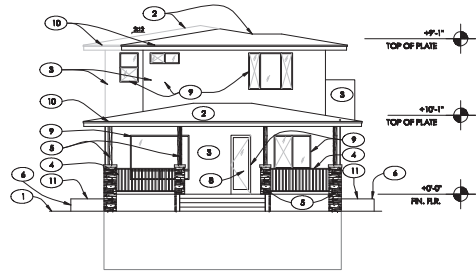

East Elevation
18' x 14'

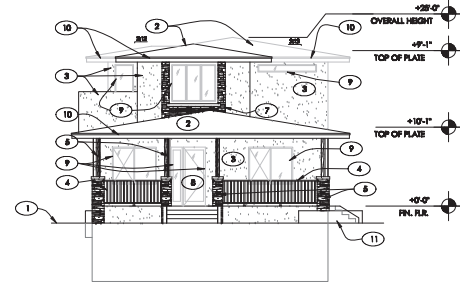

West Elevation
18' x 14'

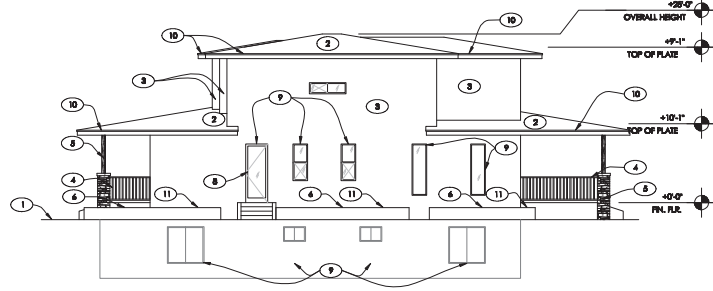

South Elevation
18' x 14'

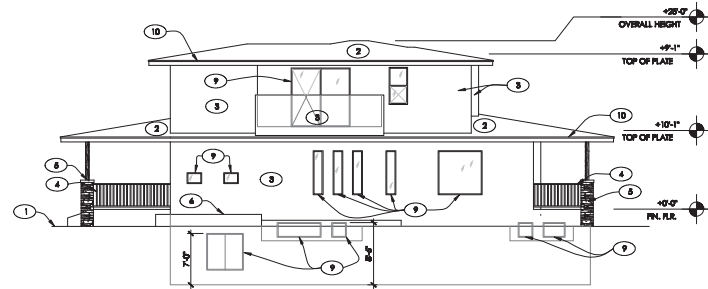

North Elevation
18' x 14'

Keynotes

1. Stop grade away from house of a minimum of 2' within 10' (R401.3)
2. Asphalt shingle roof system. ESR data to be provided to Inspector in the field.
3. Stucco system.
4. 1" Metal Railing - to be selected by owner.
5. All pillars to be stone mastic base, stone cap, and wood post.
6. Metal Planter Box.
7. Stone Mosaic pop-out.
8. Single Lite Wood Door.
9. Provide continuous sealant bead where stucco abuts window and doorframes. Use manufacturer's recommended caulk/sealing on all penetrations.
10. Roof flashing per transition.
11. Egress Well.

Special Notes

1. PROVIDE WEATHER FLASHING/PROOFING AT EXTERIOR WALL PENETRATIONS INCLUDING WINDOWS, DOORS, AND VENTS PER R703.8.

Header Details



1. PROVIDE WEATHER FLASHING/PROOFING AT EXTERIOR WALL PENETRATIONS INCLUDING WINDOWS, DOORS, AND VENTS PER R703.8.



2. PROVIDE WEATHER FLASHING/PROOFING AT EXTERIOR WALL PENETRATIONS INCLUDING WINDOWS, DOORS, AND VENTS PER R703.8.

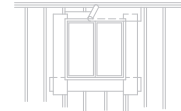

3. PROVIDE WEATHER FLASHING/PROOFING AT EXTERIOR WALL PENETRATIONS INCLUDING WINDOWS, DOORS, AND VENTS PER R703.8.

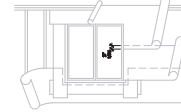

4. PROVIDE WEATHER FLASHING/PROOFING AT EXTERIOR WALL PENETRATIONS INCLUDING WINDOWS, DOORS, AND VENTS PER R703.8.

Attic Ventilation Calculations

GARAGE ROOF AREA - 924 SQ.FT. HIGHLOW VENTING @ 1/200

REQUIRED AREA:
 924 SQ.FT. / 200 = 4.62 SQ.FT. X 144 = **288 SQ.IN.**
 805 HIGH - 228 SQ.IN. 805 LOW - 228 SQ.IN.

PROVIDED:
 HIGH: 27 LIN.FT. OF RIGID ROLL PLUS @ 13 SQ.IN. PER LIN.FT. = 361 SQ.IN.
 LOW: (4) 3 1/2" X 22 1/2" SCREENED GABLE VENTS @ 89 SQ.IN. = 356 SQ.IN.

TOTAL PROVIDED: **717 SQ.IN.**

===== RIDGE VENTING
 ■ ■ ■ ■ ■ SCREENED GABLE VENTING
 ■ ■ ■ ■ ■ CHAIRSEAT CLOAZED VENTING

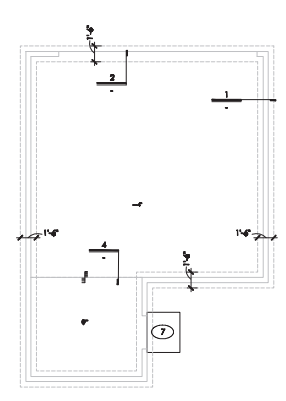
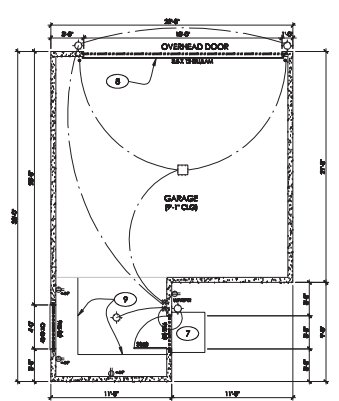
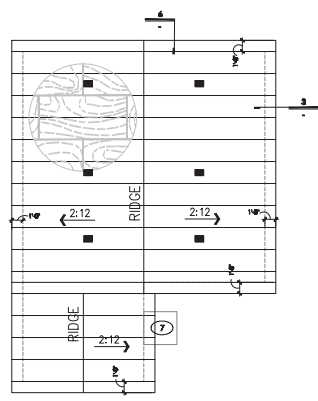

Keynotes

1. Slop grade away from house of a minimum of 2" within 10' (R401.3)
2. Asphalt shingle roof system, ESR data to be provided to inspector in the field.
3. Stucco system
4. Solid Wood Door.
5. Provide continuous sealant bead where Stucco abuts window and doorframes. Use manufacturer's recommended counter-flashing on all penetrations.
6. Roof flashing per transition.
7. 36"x36" concrete landing.
8. Roll up garage door.
9. Cabinets by owner.

Special Notes

1. PROVIDE HEADER FLASHING/ROOFING AT EXTERIOR WALL PENETRATIONS, INCLUDING WINDOWS, DOORS, AND VENTS PER R703.8.

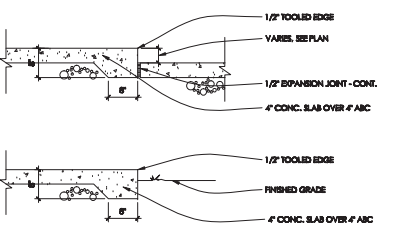
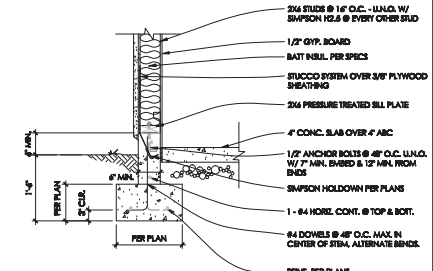
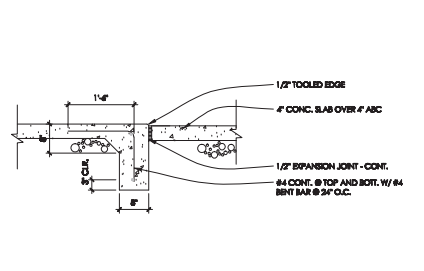
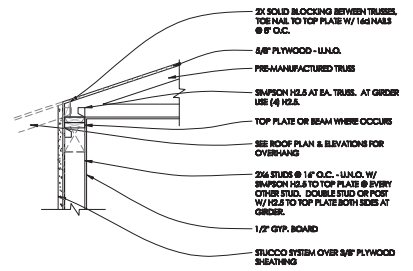
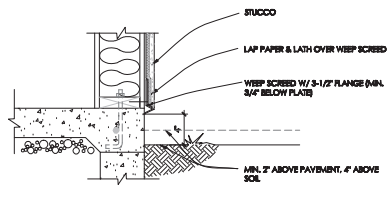
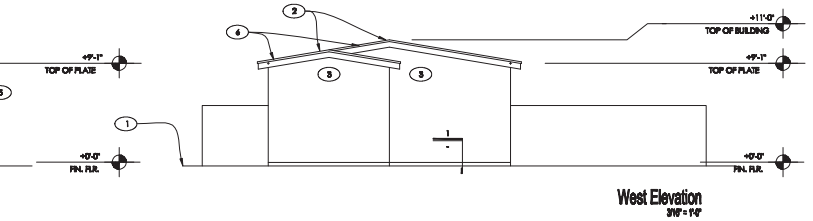
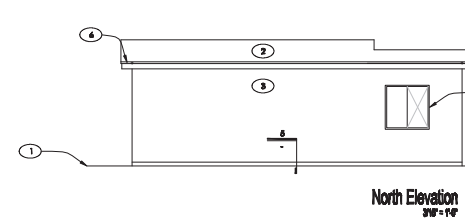
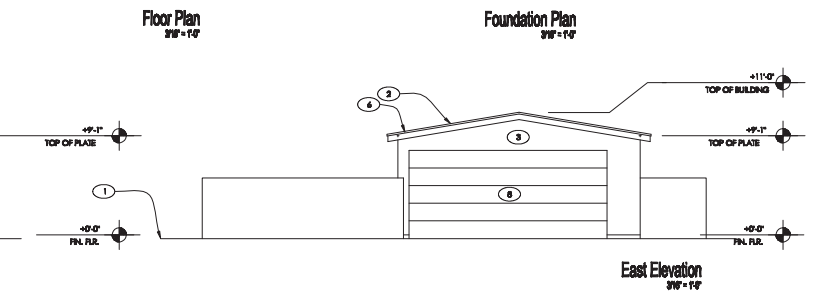
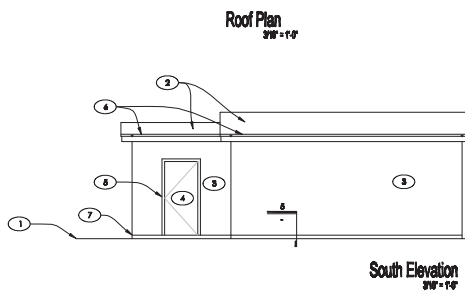
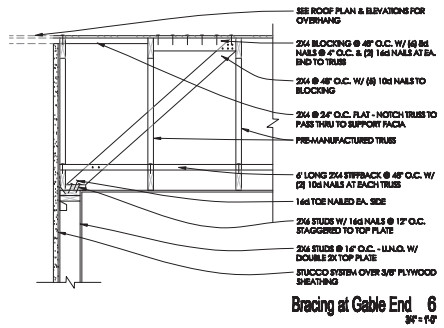

Slab Turndown 4
 31'0" x 14'0"

Truss at Bearing 3
 12'0" x 14'0"

Slab Turndown at Garage 2
 12'0" x 14'0"

Concrete Stem at Garage 1
 12'0" x 14'0"

This drawing is the property of JCL design/build and is limited to the original use for which it was prepared. Changes, reproduction, or copying in any form party of this drawing for any other use is not permitted without written consent of JCL design/build.

81 notification letters were mailed (see attached list) and a notification sign was posted at the property on November 21, 2018.

The meeting took place at 919 S. Maple Avenue from 5pm-6pm on Thursday December 6, 2018. The meeting was run by Tad and Katina Skinner.

There were a total of 81 individuals notified. Aside from the two city officials, the architect, and the owners, there were twelve individuals at the meeting. This included at least two who were outside the 600 foot notice area. Additionally, prior to the meeting we received a letter from one owner who was supportive of our plans for the use permit. Also, the owner of the property directly to the south of our property (and who will be most affected by our 2 foot use permit) has called and texted several times and is completely supportive of our plans to obtain a use permit.

At the meeting, our request for the use permit was only brought up once. To our understanding, notifying the neighborhood of the request for a use permit was the purpose of the meeting. The one comment was general in nature about use permits and not a question directed to us. Rather, it was an angry statement about the city and not about our property at all.

There were concerns and issues about our decision to demolish the house (again, not the purpose of the meeting or the use permit). The most vocal comments were from an individual who does not live within the 600 foot radius of the property (though she is somehow attached to the Maple Ash Neighborhood Association).

There was also a comment of support for demolishing and having more owner-occupied homes in the neighborhood.

We stated that we have been through the process with the Historic Preservation Office and have abided by all city requirements regarding obtaining permission to demolish.

Finally, there were also concerns about the size and use of the home. A couple of people questioned whether the owners would actually live in the home. Though this was not the purpose of the meeting, we responded that the owners will live in the home and that it is not an investment property. Interestingly, several of the people in attendance own investment properties in the neighborhood.

In short, there were no specific questions or comments to us about the use permit so we cannot say that there was actually opposition to that. There has been support for the use permit from others who did not attend the meeting.

We've attached certain documents that have been requested.

- a. There will be No significant vehicular or pedestrian traffic for this proposed use permit as it is for a single family home
- b. There will be no significant emissions of any kind as it will be a single family home used for owner occupied use.
- c. We believe that this use permit will allow for a significant add value to the neighborhood and will help to revitalize the area for many generations to come
- d. The proposed dwelling is designed in such a way as to keep the street scape intact and we believe by using a mid-century prairie style design, fits quite nice with the surrounding structures and into the fabric of the street scape.
- e. As it will be a single family home, there will be no significant disruptive behavior to the neighborhood

Names of those who attended that were willing to sign in:

Jenny Lucier
823 s maple

Viginia Sandsked
117 s ash ave.

Steve Abrahamson
City of tempe

Lee Jiminez
City of tempe

Karyn Gitlis and Phil Douglass

Joan Bahamonde and rick Hervig

Jason and Christy Kimball

Tom allen

Ben Hurlbot and Molly brizgys
1008 s. maple

Tad and Katina Skinner (owners)

Jared Lineberger (designer)

Jared Lineberger

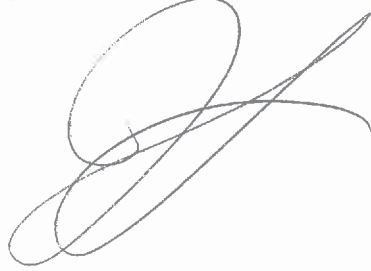
A stylized, cursive handwritten signature of Jared Lineberger, consisting of several overlapping loops and a long horizontal stroke.

12.10.18

Fw: 919 S. Maple

From: Tad Skinner [REDACTED]
To: solidrock15@yahoo.com
Date: Sunday, December 9, 2018, 3:16 PM MST

In case it's helpful, here's the email I sent to Karyn and Ginny (this is not Jenny Lucier) at the Historic Preservation Officer, John Southard's recommendation. I never received a response from Karyn or Ginny or anyone else in the neighborhood.

----- Forwarded Message -----

From: Tad Skinner <[REDACTED]>
To: karyn.gitlis [REDACTED] sandstedt1 [REDACTED]
Sent: Friday, August 31, 2018, 4:49:41 PM MST
Subject: 919 S. Maple

Hello Karyn and Ginny,

My name is Tad Skinner and my wife, Katina, and I recently purchased the property at 919 S. Maple. Though we've lived in Tempe for 15 years, we love the Maple-Ash neighborhood. We've been searching for a home in that neighborhood for quite some time.

The house at 919 is rather old and has not been well-maintained for several years, unfortunately. The roof, floor, and electrical are not in the best of shape. Our intention is to remove or demolish the home and start over by building a home in the same style that will hopefully be there for another 100 years. We have asked John Southard, the Tempe Historic Preservation Officer, if there is anyone he knows that would like to remove the home. He is doubtful as the house is not historic and in poor shape. If you know of someone, would you please let us know?

Additionally, we want to be clear that our intention is for our family to live in the home we build for many years. And, we don't want to build anything that takes away from the character of the neighborhood - that's one of the things we love about the neighborhood! John Southard gave us your email addresses as the two of you are actively involved in the Maple-Ash Neighborhood Association. Would you have any recommendations for us as we make preparations to move into the neighborhood?

Thank you
Tad and Katina Skinner



Fw: neighborhood support for your family home

From: Tad Skinner ([REDACTED])

To: solidrock15@yahoo.com

Date: Sunday, December 9, 2018, 5:35 PM MST

----- Forwarded Message -----

From: Steve Tseffos < [REDACTED] >

To: "tad_skinner [REDACTED]" < [REDACTED] >

Sent: Sunday, December 9, 2018, 1:55:57 PM MST

Subject: neighborhood support for your family home

Dear planners and Design Review Board members,

I am writing in support of my next door neighbor, the Skinner family, who have plans for a single-family home at 919 Maple Street. I am supporting the project both as a neighbor who owns the majority of the block bordering Mill, Maple, Ninth and Tenth streets and as a leader in M.A.P.L.E. (Maple Ash Property Landowners Entity), a group recognized by the city as being equal to a neighborhood association.

We support the Skinner family for several important reasons and hope and expect that you will do the same.

The variance being sought is on the south side of the proposed home, next to my house at 921 South Maple. To be clear, I am the homeowner directly impacted by the variance. I also own the two homes south of 921 - 923 and 949 South Maple. In addition, I own the five properties behind the Skinners across the alley on Mill Avenue (except for the University Motel and the Subway restaurant on the corner of Tenth and Mill).

The variance is negated by good design and the family's desire to owner-occupy the home. The property is zoned R-3r which would allow for three stories - the Skinners choose two stories. I would have supported three stories had they chosen to do that, but my point is they are already making accommodations and showing sensitivity to those who desire a lower scale.

The Skinners are investing approximately \$1 million into a neighborhood that is sorely in need of homeownership and new investment. Our vision and my work for almost 30 years has been to replace the substandard properties in the neighborhood with new owner-occupied housing to mix with properties worth saving and lessen the overabundance of rental properties. Pioneers like the Skinners are few and far between. Most families will not invest that kind of money only to met by opposition from people who do not respect personal property rights.

Any opposition to the Skinners is shameful and anyone not welcoming this family with open arms is shameful. Please don't be part of it. If there is opposition

to this project it is not based on what is being built and that is the only thing this board and the city should be focused on. There are only a couple people in the neighborhood who have kept the neighborhood from being a great place to live by putting houses above people...people like the Skinners. The Skinners come with the best of intentions and a desire to be close to ASU for their children. The people opposing them own a lot of rental properties and do not want owner-occupied housing because they are afraid new owners will complain about their shoddy rental properties.

The Skinners have done everything you would hope for - hired a good architect, worked with the neighbors early in the process and looked for input.

They are building a quality home and seeking only a minimal variance. I look forward to having their home next to my properties and hope to work with them in the future to continue improving an important piece of downtown Tempe. I have personally spoken to more than a dozen property owners in the neighborhood and on this block, none opposed the variance and were looking forward to new investment in the neighborhood. There are many property owners supporting the Skinners and their vision for the neighborhood and I am one of them.

Sincerely

Steve Tseffos as an individual and M.A.P.L.E

Dear Neighbor,

We own the property located at 919 S Maple st. We are Proposing to construct a new single family dwelling on the property, to do this we will be requesting a variance to the side yard setback from 10' to 8'.

We would like to invite you to our property on December 6th at 5pm so that we may show you our proposed plans, answer questions, and address concerns.

We will be submitting an application to the city and anticipate a public hearing before the hearing officer on January 8th, 2019 at 5pm in the city council chambers of city hall at 31 east 5th street, tempe az 85281

Sincerely

Tad and Katina Skinner

I OWN PROPERTY AT
1005 & 1111 SOUTH MAPLE
AND HAVE NO PROBLEMS WITH
YOUR SETBACK PLANS.
WALENBERG

D. Douglas

529 E Mountain Sky Ave
Phoenix, AZ 85048-1880

PHOENIX AZ 850

01 DEC 2018 PM 10:1



TAD SKINNER
1950 E. CALLE DE ARCOS
TEMPE AZ 85284

Skinner residence site images

