

**CITY OF TEMPE
DEVELOPMENT REVIEW COMMISSION**

**Meeting Date: 03/12/2019
Agenda Item: 5**

ACTION: Request a Use Permit to allow a drive-through in the CSS (Commercial Shopping and Service) zoning district; a Use Permit to exceed 125% of the minimum required parking; and a Development Plan Review for a new 828 square-foot restaurant for HUMAN BEAN, located at 1602 North Scottsdale Road. The applicant is Ross Design Group.

FISCAL IMPACT: There is no fiscal impact on City funds.

RECOMMENDATION: Approve, subject to conditions

BACKGROUND INFORMATION: HUMAN BEAN (PL180354) is a proposed redevelopment of a site, removing a vacant building and building a smaller restaurant coffee kiosk located on the northwest corner of North Scottsdale Road and East Hancock Avenue. The site was originally a convenience store, and later converted to a tanning salon; the last use was a clothing store. The proposed project would remove the existing building but keep a portion of the existing parking and perimeter landscape, while installing a new smaller building with a drive through service for coffee, a new patio and enhanced landscape throughout the site. The current site has 38 existing parking spaces, the new design removes 26 spaces, keeps 7 spaces along the west side and rebuilds 7 spaces closer to the coffee shop. Due to the small size of the new building, the maximum parking allowed is 7 parking spaces; although the new development is removing 26 spaces, it is required to have a use permit to exceed the 7 maximum spaces to allow 14 total on-site parking spaces. A recently constructed cell tower would remain with the proposed project and is under lease with Verizon. The request includes the following:

- ZUP190009 Use Permit for a drive-through in the CSS, Commercial Shopping and Service District
- ZUP190010 Use Permit to exceed 125% of the allowed minimum required parking of 7 spaces to allow 14 spaces.
- DPR190019 Development Plan Review including site plan, building elevations, and landscape plan

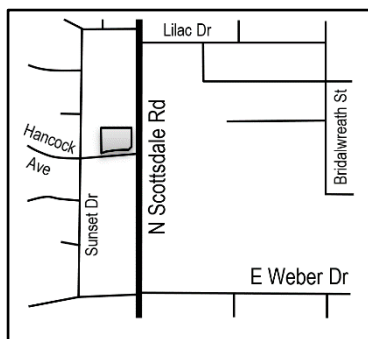

Existing Property Owner	Scott Hintze, Scottsdale & Hancock, LLC
Applicant	David Ross, Ross Design Group, LLC
Zoning District	CSS, Commercial Shopping and Service
Gross / Net site area	.730 acres
Total Building Area	828 s.f.
Lot Coverage	2.6% (50% maximum allowed)
Building Height	20' (35' maximum allowed)
Building Setbacks	34' east front, 153' west rear, 54' north side, 49' south street side (0' front, 10' rear, 0' side, 0' street side minimum in CSS)
Landscape area	35% (15% minimum required)
Vehicle Parking	14 spaces (6 min. required, 7 max. allowed)
Bicycle Parking	2 spaces (2 min. required)

ATTACHMENTS: Development Project File

STAFF CONTACT(S): Diana Kaminski, Senior Planner (480) 858-2391

Department Director: Chad Weaver, Community Development Director

Legal review by: N/A

Prepared by: Diana Kaminski, Senior Planner

Reviewed by: Suparna Dasgupta, Principal Planner

COMMENTS:

This site is located on the north west corner of north Scottsdale Road and east Hancock Avenue in the CSS, Commercial Shopping and Service zoning district in the Cavalier Hills Unit Two Subdivision. Prior uses of the site included a convenience store, tanning salon and clothing store, all within the existing vacant 2,978 s.f. building. Existing entitlements for this property that will remain in effect are a use permit to allow a 75 feet tall wireless telecommunication facility (monopine) for VERIZON PHO STAR WOMAN (PL170277). Existing uses on the site include a vacant building with 38 parking spaces, the retail building and 26 of the parking spaces would be removed with this project, to allow a new 828 s.f. coffee kiosk with drive-through and walk-up service (no indoor seating). This request includes

- ZUP190009 Use Permit for a drive-through in the CSS, Commercial Shopping and Service District
- ZUP190010 Use Permit to exceed the allowed maximum surface parking of 7 spaces to allow 14 spaces.
- DPR Development Plan Review including site plan, building elevations, and landscape plan

The applicant is requesting the Development Review Commission take action on the items listed above.

SITE PLAN REVIEW

Staff has reviewed multiple concepts for use of this site over the past five years, none of which progressed beyond preliminary reviews. The current applicant met with staff to review the prior comments. Staff recommended that an outdoor patio be included in any restaurant on site, since these are typically desired and added on later.

July 19, 2018 the first site plan for this project was reviewed, that outlined required street tree, buffer and drive through landscape requirements. As an entirely new building, the project was subject to full engineering, including driveway modifications of accessibility. Staff discussed the long-range intent of the property and asked whether an adaptive reuse of the existing building would meet the owner's needs in lieu of demolition and a new building. After evaluating options, the owner chose to invest in the full site development to meet the functional needs of the coffee shop.

October 17, 2018, the second review included the elevations and landscape plan. Staff comments included requirement that insect air curtain be located inside the building window, not externally mounted and that the SES should be fully screened, not behind a perforated metal panel. Staff asked for the service doors to be painted to match the primary building color and for stone masonry that was shown only on the taller entrance element to be added to the wainscot around the rest of the building. The existing screen wall hid most of the lower portion of the building from view, and the applicant requested to only add the wainscot on the drive through side, since the service doors on the south elevation would take up the majority of the wall, and the west side was hidden by the patio fence and furnishings. Staff asked for the stone to be added at the corners of the perimeter screen wall, to enhance the view of the site from both street frontages. This addition was made. Staff commented on the excess parking, if removed would not require a use permit to exceed 125%. Staff has been evaluating this maximum restriction as it applies to smaller buildings, where the minimum and maximum number of spaces may only allow 1 space above the maximum. Until a code text change is made to address these smaller buildings, the use permit is the solution available for those who wish to have more parking. With the

December 12, 2018, the third review included all the required drawings for a formal submittal. Comments on the landscape questioned the number and proximity of the Cascalote in the center to each other, that they might be spaced too close together, and whether the Ruellia on the north side of the building would thrive under a shade canopy on the north side of the building. Staff requested that plants be shown at mature scale to show the true lot coverage of the planting plan. Solid Waste agreed to allow the existing single-enclosure that was just built when the cell tower went in earlier in the year. The single enclosure will be required to have two smaller bins, one for trash and one for recycling. All other comments from prior reviews were addressed.

February 5, 2019, a formal application was made for the two use permits and the development plan review.

PUBLIC INPUT

- A neighborhood meeting was not required for this request.
- At completion of the report, staff received one call regarding the project. A resident in the area expressed early concern about the use of a drive-through on this property, and that having a call box would be a disruption for the residents residing to the west of the site. The resident was put in contact with the architect who reviewed the operations of this restaurant.

PROJECT ANALYSIS

GENERAL PLAN

The proposed project conforms to the Land Use Map, and goals and objectives of the Redevelopment Element of the General Plan.

CHARACTER AREA PLAN

There is no character area plan for this area, however the proposed scale and character of the building is appropriate to the surrounding area, with similar projects along Scottsdale Road.

ZONING

The site is Zoned Commercial Shopping and Service, which allows coffee shops. The proposed project meets or exceeds all zoning and development standards for the site.

USE PERMIT

The proposed use requires a Use Permit to allow parking in excess of the maximum allowed, and a Use Permit to allow a restaurant with a drive through. The applicant has provided a letter of explanation for these two requests. Section 6-308 E Approval criteria for Use Permit (*in italics*): Below is the analysis for each of these two Use Permits.

Drive Through:

1. *Any significant increase in vehicular or pedestrian traffic.* The existing site has 38 parking spaces and a 2,978 s.f. building, which would meet the zoning requirements for a restaurant. The applicant is choosing to remove the building built in the 1970s and build a new 828 s.f. building that requires 7 parking spaces. The proposed drive through would allow 13 vehicles to stack within the development without encroachment on the public streets. All circulation would be on site. It would be anticipated that the drive through would generate more traffic during peak periods than a sit-down restaurant, however, the peak periods would not exceed standard traffic levels for restaurant uses on a commercial site.
2. *Nuisance arising from the emission of odor, dust, gas, noise, vibration, smoke, heat or glare at a level exceeding that of ambient conditions.* The proposed drive through will not have speakers for the drive through. Menu boards face south and are located approximately 120' from the west property line and approximately 160' from the back of the nearest residences to the west. The restaurant operates with an employee who walks up to the customer in the vehicle, takes the order on an ipod tablet and sends the order electronically to the building for fulfillment. A site wall and landscape separate the site from the existing alley to help buffer sound from patrons and employees talking. The area is impacted by aircraft and vehicular traffic, which affects the existing ambient conditions greater than conversation at a car window.
3. *Contribution to the deterioration of the neighborhood or to the downgrading of property values, the proposed use is not in conflict with the goals objectives or policies for rehabilitation, redevelopment or conservation as set forth in the city's adopted plans or General Plan.* The proposed use will revitalize a site that has struggled to sustain commercial uses over the years. As a vacant building there has been an increase in transient activity on site; redevelopment of the property and activation of the site will help alleviate the ongoing issues in the immediate area.
4. *Compatibility with existing surrounding structures and uses.* There are several small businesses with drive throughs in the area, including coffee, donut and fast food restaurants. This would be one of the smallest buildings on a commercial lot, but the style is compatible with surrounding architecture.
5. *Adequate control of disruptive behavior both inside and outside the premises which may create a nuisance to the surrounding area or general public.* The applicant has other coffee shops in the valley and experience with operating drive-through facilities. Up to three employees would work at the store and provide site maintenance and monitoring. All parking and circulation is on-site; the drive through is not anticipated to impact adjacent uses or the public right of way.

Exceedance of the Maximum Allowed Parking:

1. *Any significant increase in vehicular or pedestrian traffic.* The existing site has 38 parking spaces, the applicant is proposing to remove 24 spaces, 7 of the existing along the west side would remain, and 7 new spaces along the north side of the central landscape area would be added. The code only allows 7 spaces based on the size of the new building. The increase from 7 to 14 spaces would be less traffic than the existing 38 parking spaces, therefore there is no increase in traffic with this request.
2. *Nuisance arising from the emission of odor, dust, gas, noise, vibration, smoke, heat or glare at a level exceeding that of*

ambient conditions. The site is reducing paving by approximately 6,500 s.f. and adding 30 additional trees to the site and providing 35% landscape area which will significantly reduce the heat gain on site. The allowance of 14 parking spaces, broken up into 2 rows of seven with landscape islands, will not create a nuisance to the surrounding area.

3. *Contribution to the deterioration of the neighborhood or to the downgrading of property values, the proposed use is not in conflict with the goals objectives or policies for rehabilitation, redevelopment or conservation as set forth in the city's adopted plans or General Plan.* The proposed removal of 24 spaces and redevelopment of the site will enhance the area. The applicant is required to request this use permit because of the voluntary reduction in building size.
4. *Compatibility with existing surrounding structures and uses.* The properties to the north, south and east of this site are all commercial uses with large parking areas and heavily reliant on vehicle use. The proposed 7 additional parking spaces is compatible with the surrounding site design and uses.
5. *Adequate control of disruptive behavior both inside and outside the premises which may create a nuisance to the surrounding area or general public.* The proposed 7 additional parking spaces is not anticipated to impact the behavior on or off site. With 3 of the 7 required spaces used for employees, the additional parking will provide more opportunity for customers to stay on site and use the patio, activating the area rather than driving through and leaving. This activation of the site may provide surveillance to the surrounding area, providing a safer area.

The manner of conduct and the building for the proposed use will not be detrimental to persons residing or working in the vicinity, to adjacent property, to the neighborhood, or to the public welfare in general, and that the use will be in full conformity to any conditions, requirement or standards prescribed therefore by this code.

DEVELOPMENT PLAN REVIEW

Site Plan

The building is located at the eastern side of the site with the long side facing Scottsdale Road and the narrow ends of the building facing north/south. Existing curb cuts and drives will be improved to meet current standards for accessibility. Vehicles can enter from either Hancock Avenue at the south west end of the site or Scottsdale Road at the north east end of the site. The drive through starts as a double loaded lane entering from both the west and north and merging into one lane at the south end of the building, before wrapping around to the pickup window on the east side. Canopies are provided to shade both the drive through lane and the patio located on the west side of the building. There is a 3,015 s.f. lawn surrounded by trees in the middle of the site, visible from Hancock Avenue. The Verizon Cell Tower enclosure and mono-pine were installed in 2018 and will remain on the site with the new development.

Building Elevations

The 18' wide by 46' long by 15-20' tall building is a small structure with stucco and faux stone with metal accents. The building is 15' tall at the south end and 20' tall at the north end, elevating the entrance where the drive through and walk up windows are located. The west and north elevations are entirely shaded by structural metal canopy painted a bronze color. The east side is shaded over the drive through window. The south side has a small overhang over the doors. The primary building is stucco painted gold-brown. A wainscot around the west and south sides is painted a darker tone of a similar gold-brown hue. El Dorado stone is used along the wainscot on the drive through and north side, as viewed from Scottsdale Road and the entrance. The west side patio is screened by a perforated metal railing painted a bronze color. Most of the lower building is out of view due to the drive through screen walls along both streets. The stone has been added to the columns on the wall to tie the site wall into the building and provide more detailing along the street front. The taller building element is wrapped with the stone finish and accented with a darker coffee bean color to accent the windows and serve as a contrast to the sign text. The signage will be handled by separate review and is shown for reference only.

Landscape Plan

The site has an assortment of existing trees that the applicant has incorporated into the new design, providing a very diverse palette on a small site. The existing Mulga were installed by a prior owner without completing a Development Plan Review, but have been established for three years. Other existing species include the Shoestring Acacia, Sonoran Palo Verde, Mondell Pine and Thornless Mesquite. The site was originally required to use pine as a buffer to the neighborhood, when the mono-pine was approved. Since the perimeter landscape has been established for several years and does not require modification for construction of the new building, the perimeter will be kept with the mature and maturing trees, and enhanced

with additional trees and understory plants. Additional trees would include Acacia Palo Blanco along the west side of the patio for shade and accent to the lawn, Thornless Cascalote in a grove of flowering trees at the curve of the drive through, Sonoran Palo Verde at the street front to fill in adjacent trees, Thornless Mesquite in the parking islands, and Mondell Pine along the west and north perimeter. With the addition of 30 new trees, the site will have over 40 trees. Understory plants include a variety of flowering xeric species such as Bursage, Red Bird of Paradise, Compact Sage, Green Cloud Sage, Purple Muhly, Ruellia, Pink Ruellia, Blue Ruellia, Acacia redolens and Yellow Lantana. Accents include Blue Flame Agave, Century Plant and slipper Plant. The combination is a unique mix of plants that will provide color and texture with a year round buffer of non-deciduous trees.

Section 6-306 D Approval criteria for Development Plan Review (*in italics*):

1. *Placement, form, and articulation of buildings and structures provide variety in the streetscape;*
The placement of the building was determined by function of the drive-through and proximity to the street front, away from the residences. The building has articulation in both height and through use of materials, colors and canopies to provide variation.
2. *Building design and orientation, together with landscape, combine to mitigate heat gain/retention while providing shade for energy conservation and human comfort;*
The building has full shade on the north and west, partial shade on the south on the narrowest face, which is the utility end of the building, and partial shade on the east, where the drive through window is located. The use of trees on site will significantly shade the site. The use of turf will significantly cool the site, providing an oasis not commonly found on commercial sites.
3. *Materials are of a superior quality, providing detail appropriate with their location and function while complementing the surroundings;*
The proposed materials are equal to or better than the surrounding developments, with a combination of stone and stucco. The removal of the existing all stucco building with this newer building will be an enhancement to the immediate surroundings.
4. *Buildings, structures, and landscape elements are appropriately scaled, relative to the site and surroundings;*
The small building is similar in scale to other small kiosk buildings in the area and is appropriately scaled. The mono-pine will be significantly taller than the new restaurant building, which required additional pine trees to help transition the mono-pine into the landscape.
5. *Large building masses are sufficiently articulated so as to relieve monotony and create a sense of movement, resulting in a well-defined base and top, featuring an enhanced pedestrian experience at and near street level;*
The building does not have large building mass, the height is 15' at the south and 20' at the north end. The elevations include a variety of materials that define the base and top.
6. *Building facades provide architectural detail and interest overall with visibility at street level (in particular, special treatment of windows, entries and walkways with particular attention to proportionality, scale, materials, rhythm, etc.) while responding to varying climatic and contextual conditions;*
The building and site walls are integrated in colors and materials, to provide visual continuity. Each side of the building is treated appropriate to the function. The structural supports of the shade canopy enclose the building on the west and east sides, creating a porch-like appearance to the building, of similar scale to the houses within the neighborhood.
7. *Plans take into account pleasant and convenient access to multi-modal transportation options and support the potential for transit patronage;*
The site has easy access for vehicles, pedestrians, bicyclists and is served by both Orbit and bus transit. The addition of trees will provide a comfortable and aesthetically pleasant accessible site for transit users.
8. *Vehicular circulation is designed to minimize conflicts with pedestrian access and circulation, and with surrounding residential uses;*

The existing drives are being enhanced to provide safer pedestrian access and a crossing is provided for pedestrians from both street frontages.

9. *Plans appropriately integrate Crime Prevention Through Environmental Design principles such as territoriality, natural surveillance, access control, activity support, and maintenance;*

The site provides an outdoor patio overlooking the lawn area and parking, as well as a walk-up window for employee surveillance of the site. Activation of the property will enhance crime prevention in the area. The landscape is designed to provide visual surveillance and gates have been added behind the mono-pine enclosure to prevent loitering behind this enclosure.

10. *Landscape accents and provides delineation from parking, buildings, driveways and pathways;*
The landscape defines the perimeter buffer and street front as well as the parking, drive through and patio areas through changes in trees and use of understory plants.

11. *Signs have design, scale, proportion, location and color compatible with the design, colors, orientation and materials of the building or site on which they are located; and*
Signs will be handled by separate application.

12. *Lighting is compatible with the proposed building(s) and adjoining buildings and uses and does not create negative effects.*

A photometric plan was provided and reviewed. The site has been designed to minimize any light trespass to adjacent properties and to focus lighting where needed for safety and site function.

REASONS FOR APPROVAL:

1. The project meets the General Plan Projected Land Use for this site.
2. The project will meet the development standards required under the Zoning and Development Code.
3. The proposed project meets the approval criteria for Use Permits and a Development Plan Review.

Based on the information provided and the above analysis, staff recommends approval of the requested Use Permits and Development Plan Review. This request meets the required criteria and will conform to the conditions.

USE PERMITS CONDITIONS OF APPROVAL:

EACH NUMBERED ITEM IS A CONDITION OF APPROVAL. THE DECISION-MAKING BODY MAY MODIFY, DELETE OR ADD TO THESE CONDITIONS.

1. This Use Permit is valid only after a Building Permit has been obtained, the required inspections have been completed and a Final Inspection has been passed.
2. The Use Permit is valid for the plans as submitted within this application. Any additions or modifications may be submitted for review during the building plan check process.
3. If there are any complaints arising from the Use Permit that are verified by a consensus of the complaining party and the City Attorney's office, the Use Permit will be reviewed by City staff to determine the need for a public hearing to re-evaluate the appropriateness of the Use Permit, which may result in termination of the Use Permit.
4. Any intensification or expansion of use shall require a new Use Permit.
5. No live entertainment is allowed with this Use Permit.
6. Hours of operation to be no earlier than 5:00 am and no later than 9 p.m. daily.

DEVELOPMENT PLAN REVIEW CONDITIONS OF APPROVAL: (Non-standard conditions are identified in bold)

EACH NUMBERED ITEM IS A CONDITION OF APPROVAL. THE DECISION-MAKING BODY MAY MODIFY, DELETE OR ADD TO THESE CONDITIONS.

General

1. Except as modified by conditions, development shall be in substantial conformance with the site plan and building elevations submitted on February 21, 2019 and landscape plan dated January 3, 2019. Minor modifications may be reviewed through the plan check process of construction documents; major modifications will require submittal of a Development Plan Review.

Site Plan

2. Provide service yard and mechanical (cooling tower/generator) yard walls that are at least 8'-0" tall as measured from adjacent grade and are at least the height of the equipment being enclosed, whichever is greater. Verify height of equipment and mounting base to ensure that wall height is adequate to fully screen the equipment.
3. Provide gates of steel vertical picket, steel mesh, steel panel or similar construction. Where a gate has a screen function and is completely opaque, provide vision portals for visual surveillance. Provide gates of height that match that of the adjacent enclosure walls. Review gate hardware with Building Safety and Fire staff and design gate to resolve lock and emergency ingress/egress features that may be required.
4. Provide upgraded paving at each driveway consisting of integral colored unit paving. Extend this paving in the driveway from the right-of-way line to 20'-0" on site and from curb to curb at the drive edges. From sidewalk to right-of-way line, extend concrete paving to match sidewalk.
5. Utility equipment boxes for this development shall be finished in a neutral color (subject to utility provider approval) that compliments the coloring of the buildings.
6. Place exterior, freestanding reduced pressure and double check backflow assemblies in pre-manufactured, pre-finished, lockable cages (one assembly per cage). If backflow prevention or similar device is for a 3" or greater water line, delete cage and provide a masonry or concrete screen wall following the requirements of Standard Detail T-214.

Floor Plans

7. Provide visual surveillance by means of fire-rated glazing assemblies from stair towers into adjacent circulation spaces.
8. Public Restroom Security:
 - a. Single user restroom door hardware:
 - 1) Provide a key bypass on the exterior side

Building Elevations

9. The materials and colors are approved as presented:
 - Roof – flat painted white, with parapet screen
 - Primary Building – Synthetic stucco system painted Sherwin Williams SW7521 Dormer Brown (gold-brown)
 - Secondary Building – Synthetic stucco system painted Sherwin Williams SW6006 Black Bean (dark brown)
 - Building Accent – Synthetic stucco system painted Sherwin Williams SW7525 Tree Branch (medium gold-brown)
 - Masonry Accent – El Dorado Warm Springs Ledge Panel stone veneer
 - Window Frames – Dark Anodized Bronze (**insect screen to be installed interior to the window, not externally mounted**)
 - Glazing – Clear, Low-E
 - Trim - Painted Steel Dark Bronze

Provide primary building colors and materials with a light reflectance value of 75 percent or less. Additions or modifications may be submitted for review during building plan check process.

10. Provide secure roof access from the interior of the building. Do not expose roof access to public view.

11. Conceal roof drainage system within the interior of the building.
12. Incorporate lighting, address signs, and incidental equipment attachments (alarm klaxons, security cameras, etc.) where exposed into the design of the building elevations. Exposed conduit, piping, or related materials is not permitted.
13. Locate the electrical service entrance section (S.E.S.) inside the building or inside a secure yard that is concealed from public view.

Lighting

14. Illuminate building entrances from dusk to dawn to assist with visual surveillance at these locations.

Landscape

15. Arterial street trees shall be a minimum of 36" box specimens and a minimum of 1 ½" caliper trunk.
16. Irrigation notes:
 - a. Provide dedicated landscape water meter.
 - b. Provide pipe distribution system of buried rigid (polyvinylchloride), not flexible (polyethylene). Use of schedule 40 PVC mainline and class 315 PVC ½" feeder line is acceptable. Class 200 PVC feeder line may be used for sizes greater than ½". Provide details of water distribution system.
 - c. Locate valve controller in a vandal resistant housing.
 - d. Hardwire power source to controller (a receptacle connection is not allowed).
 - e. Controller valve wire conduit may be exposed if the controller remains in the mechanical yard.
 - f. Provide temporary irrigation to existing landscape on site or on the street frontages for period of time that irrigation system is out of repair. Design irrigation so that the existing plants on site or in frontages are irrigated as part of the reconfigured system at the conclusion of this construction.
17. Include requirement to de-compact soil in planting areas on site and in public right of way and remove construction debris from planting areas prior to landscape installation.
18. Top dress planting areas with a rock or decomposed granite application. Provide rock or decomposed granite of 2" uniform thickness. Provide pre-emergence weed control application and do not underlay rock or decomposed granite application with plastic.

Building Address Numerals

19. Provide address numerals on the north, west and east elevations.
 - a. Conform to the following for building address signs:
 - 1) Provide street number only, not the street name
 - 2) Compose of 10" high, individual mount, metal reverse pan channel characters.
 - 3) Self-illuminated or dedicated light source.
 - 4) On multi-story buildings, locate no higher than the second level.
 - 5) Coordinate address signs with trees, vines, or other landscaping, to avoid any potential visual obstruction.
 - 6) Do not affix numbers or letters to elevation that might be mistaken for the address.
 - b. Utility meters shall utilize a minimum 1" number height in accordance with the applicable electrical code and utility company standards.

CODE/ORDINANCE REQUIREMENTS:

THE BULLETED ITEMS REFER TO EXISTING CODE OR ORDINANCES THAT PLANNING STAFF OBSERVES ARE PERTINENT TO THIS CASE. THE BULLET ITEMS ARE INCLUDED TO ALERT THE DESIGN TEAM AND ASSIST IN OBTAINING A BUILDING PERMIT AND ARE NOT AN EXHAUSTIVE LIST.

USE PERMIT: The Use Permit is valid for HUMAN BEAN and may be transferable to successors in interest through an administrative review with the Community Development Director, or designee.

SITE PLAN REVIEW: Verify all comments by all departments on each Preliminary Site Plan Review. If questions arise related to specific comments, they should be directed to the appropriate department, and any necessary modifications coordinated with all concerned parties, prior to application for building permit. Construction Documents submitted to the Building Safety Division will be reviewed by planning staff to ensure consistency with this Design Review approval prior to issuance of building permits.

DEADLINE: Development plan approval shall be void if the development is not commenced or if an application for a building permit has not been submitted, whichever is applicable, within twelve (12) months after the approval is granted or within the time stipulated by the decision-making body. The period of approval is extended upon the time review limitations set forth for building permit applications, pursuant to Tempe Building Safety Administrative Code, Section 8-104.15. An expiration of the building permit application will result in expiration of the development plan.

STANDARD DETAILS:

- Access to Tempe Supplement to the M.A.G. Uniform Standard Details and Specifications for Public Works Construction, at this link: <http://www.tempe.gov/city-hall/public-works/engineering/standards-details> or purchase book from the Public Works Engineering Division.
- Access to refuse enclosure details DS116 and DS118 and all other Development Services forms at this link: <http://www.tempe.gov/city-hall/community-development/building-safety/applications-forms>. The enclosure details are under Civil Engineering & Right of Way.

BASIS OF BUILDING HEIGHT: Measure height of buildings from top of curb at a point adjacent to the center of the front property line.

WATER CONSERVATION: Under an agreement between the City of Tempe and the State of Arizona, Water Conservation Reports are required for landscape and domestic water use for the non-residential components of this project. Have the landscape architect and mechanical engineer prepare reports and submit them with the construction drawings during the building plan check process. Report example is contained in Office Procedure Directive # 59. Refer to this link: <http://www.tempe.gov/home/showdocument?id=5327>. Contact the Public Works Department, Water Conservation Division with questions regarding the purpose or content of the water conservation reports.

HISTORIC PRESERVATION: State and federal laws apply to the discovery of features or artifacts during site excavation (typically, the discovery of human or associated funerary remains). Contact the Historic Preservation Officer with general questions. Where a discovery is made, contact the Arizona State Historical Museum for removal and repatriation of the items.

POLICE DEPARTMENT SECURITY REQUIREMENTS:

- Refer to Tempe City Code Section 26-70 Security Plans.
- Design building entrance(s) to maximize visual surveillance of vicinity. Limit height of walls or landscape materials, and design columns or corners to discourage ambush.
- Maintain distances of 20'-0" or greater between a pedestrian path of travel and any hidden area to allow for increased reaction time and safety.
- Follow the design guidelines listed under appendix A of the Zoning and Development Code. In particular, reference the CPTED principal listed under A-II Building Design Guidelines (C) as it relates to the location of pedestrian environments and places of concealment.
- Provide a security vision panel at service and exit doors (except to rarely accessed equipment rooms) with a 3" wide high strength plastic or laminated glass window, located between 43" and 66" from the bottom edge of the door.

TRAFFIC ENGINEERING:

- Provide 8'-0" wide public sidewalk along arterial roadways, or as required by Traffic Engineering Design Criteria and Standard Details.
- Construct driveways in public right of way in conformance with Standard Detail T-320.

- Correctly indicate clear vision triangles at both driveways on the site and landscape plans. Identify speed limits for adjacent streets at the site frontages. Begin sight triangle in driveways at point 15'-0" in back of face of curb. Consult Intersection Sight Distance memo, available from Traffic Engineering if needed www.tempe.gov/index.aspx?page=801. Do not locate site furnishings, screen walls or other visual obstructions over 2'-0" tall (except canopy trees are allowed) within each clear vision triangle.

FIRE:

- Clearly define the fire lanes. Ensure that there is at least a 20'-0" horizontal width, and a 14'-0" vertical clearance from the fire lane surface to the underside of tree canopies or overhead structures. Layout and details of fire lanes are subject to Fire Department approval.

CIVIL ENGINEERING:

- An Encroachment Permit or License Agreement must be obtained from the City for any projections into the right of way or crossing of a public utility easement, prior to submittal of construction documents for building permit.
- Maintain a minimum clear distance of twenty-four (24) feet between the sidewalk level and any overhead structure.
- Underground utilities except high-voltage transmission line unless project inserts a structure under the transmission line.
- Coordinate site layout with Utility provider(s) to provide adequate access easement(s).
- Clearly indicate property lines, the dimensional relation of the buildings to the property lines and the separation of the buildings from each other.
- Verify location of any easements, or property restrictions, to ensure no conflict exists with the site layout or foundation design.
- 100-year onsite retention required for this property, coordinate design with requirements of the Engineering Department.

SOLID WASTE SERVICES:

- Enclosure indicated on site plan is exclusively for refuse. Construct walls, pad and bollards in conformance with standard detail DS-116.
- Contact Public Works Sanitation Division to verify that vehicle maneuvering and access to the enclosure is adequate. Refuse staging, collection and circulation must be on site; no backing onto or off of streets, alleys or paths of circulation.
- Gates for refuse enclosure(s) are not required, unless visible from the street. If gates are provided, the property manager must arrange for gates to be open from 6:00am to 4:30pm on collection days.

PARKING SPACES:

- Verify conformance of accessible vehicle parking to the Americans with Disabilities Act and the Code of Federal Regulations Implementing the Act. Refer to Building Safety ADA Accessible Parking Spaces Marking/Signage on Private Development details.
- At parking areas, provide demarcated accessible aisle for disabled parking.
- Distribute bike parking areas nearest to main entrance(s). Provide parking loop/rack per standard detail T-578. Provide 2'-0" by 6'-0" individual bicycle parking spaces. One loop may be used to separate two bike parking spaces. Provide clearance between bike spaces and adjacent walkway to allow bike maneuvering in and out of space without interfering with pedestrians, landscape materials or vehicles nearby.

ZONING AND DEVELOPMENT CODE:

- Specific requirements of the **Zoning and Development Code (ZDC)** are not listed as a condition of approval, but will apply to any application. To avoid unnecessary review time and reduce the potential for multiple plan check submittals, become familiar with the ZDC. Access the ZDC through www.tempe.gov/zoning or purchase from Community Development.

LIGHTING:

- Design site security light in accordance with requirements of ZDC Part 4 Chapter 8 (Lighting) and ZDC Appendix E

(Photometric Plan).

- Indicate the location of all exterior light fixtures on the site, landscape and photometric plans. Avoid conflicts between lights and trees or other site features in order to maintain illumination levels for exterior lighting.

LANDSCAPE:

- Trees shall be planted a minimum of 16'-0" from any existing or proposed public utility lines. The tree planting separation requirements may be reduced to no less than 8'-0" from utility lines upon the installation of a linear root barrier. Per Detail T-460, the root barrier shall be a continuous material, a minimum of 0.08" thick, installed to a minimum depth of 4'-0" below grade. The root barrier shall extend 6'-0" on either side of the tree parallel to the utility line for a minimum length of 12'-0". Final approval is subject to determination by the Public Works, Water Utilities Division.
- Prepare an existing plant inventory for the site and adjacent street frontages. The inventory may be prepared by the Landscape Architect or a plant salvage specialist. Note original locations and species of native and "protected" trees and other plants on site. Move, preserve in place, or demolish native or "protected" trees and plants per State of Arizona Agricultural Department standards. File Notice of Intent to Clear Land with the Agricultural Department. Notice of Intent to Clear Land form is available at <https://agriculture.az.gov/plantsproduce/native-plants>. Follow the link to "applications to move a native plant" to "notice of intent to clear land".

SIGNS: Separate plan review process is required for signs in accordance with requirements of ZDC Part 4 Chapter 9 (Signs). Refer to www.tempe.gov/signs.

DUST CONTROL: Any operation capable of generating dust, include, but not limited to, land clearing, earth moving, excavating, construction, demolition and other similar operations, that disturbs 0.10 acres (4,356 square feet) or more shall require a dust control permit from the Maricopa County Air Quality Department (MCAQD). Contact MCAQD at <http://www.maricopa.gov/qa/>.

HISTORY & FACTS:

1930-1970	The surrounding area transformed from raw desert to agricultural, to residential to the west, the frontage along Scottsdale Road remained vacant until the early 1970s. The specific site was developed in the late 1970s and has remained with the same driveway and parking configuration since original construction.
August 27, 1959	City Council approved Cavalier Hills Unit 2 Subdivision Plat, which included tracts along Scottsdale Road.
April 19, 1978	Design Review Board approved a building, landscape and site design for U-Totem Food Market in the CCR Convenience Commercial Residence District, subject to conditions.
April 26, 1978	Board of Adjustment approved a Use Permit for U Totem Markets to operate a convenience market in the CCR zoning district.
September 5, 1984	Design review Board approved signage for a Circle K at 1602 N. Scottsdale Road. The site functioned as a convenience store until conversion to Sun Chain Tanning from 2007 to 2011.
December 30, 2011	Community Development Planning Division approved a Development Plan Review for building modifications and a 2,280 s.f. addition and new patio. This project did not move forward, the site remained vacant and for sale for several years. In 2015 Anton Uniforms expanded from their location in the County Island further south and operated a school uniform store out of the existing building at 1602 North Scottsdale Road.
August 4, 2015	Hearing Officer approved use permit to allow a 75-foot-tall wireless communications facility (monopine) for VERIZON WIRELESS – PHO STAR WOMAN / SUN STATE TOWERS –

HANCOCK AZ01-013 (PL150279), located at 1602 North Scottsdale Road within the CSS, Commercial Shopping & Services District.

March 6, 2018 Hearing Officer continued VERIZON PHO STAR WOMAN (PL170277) to be reheard either at the March 20, 2018 or April 3, 2018 Hearing Officer public hearing; depending on applicant's ability to submit a revised application that addresses neighborhood concerns and consultation with the property owner.

April 3, 2018 Hearing Officer approved the requested use permit to allow a 75 feet tall wireless telecommunication facility (monopine). Later in the year, Anton Uniforms closed the retail operations at this location and consolidated back to their original location further south.

ZONING AND DEVELOPMENT CODE REFERENCE:

Section 6-306, Development Plan Review

Section 6-308, Use Permit

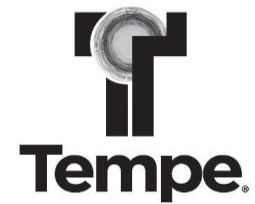

DEVELOPMENT PROJECT FILE

for

HUMAN BEAN
(PL180354)









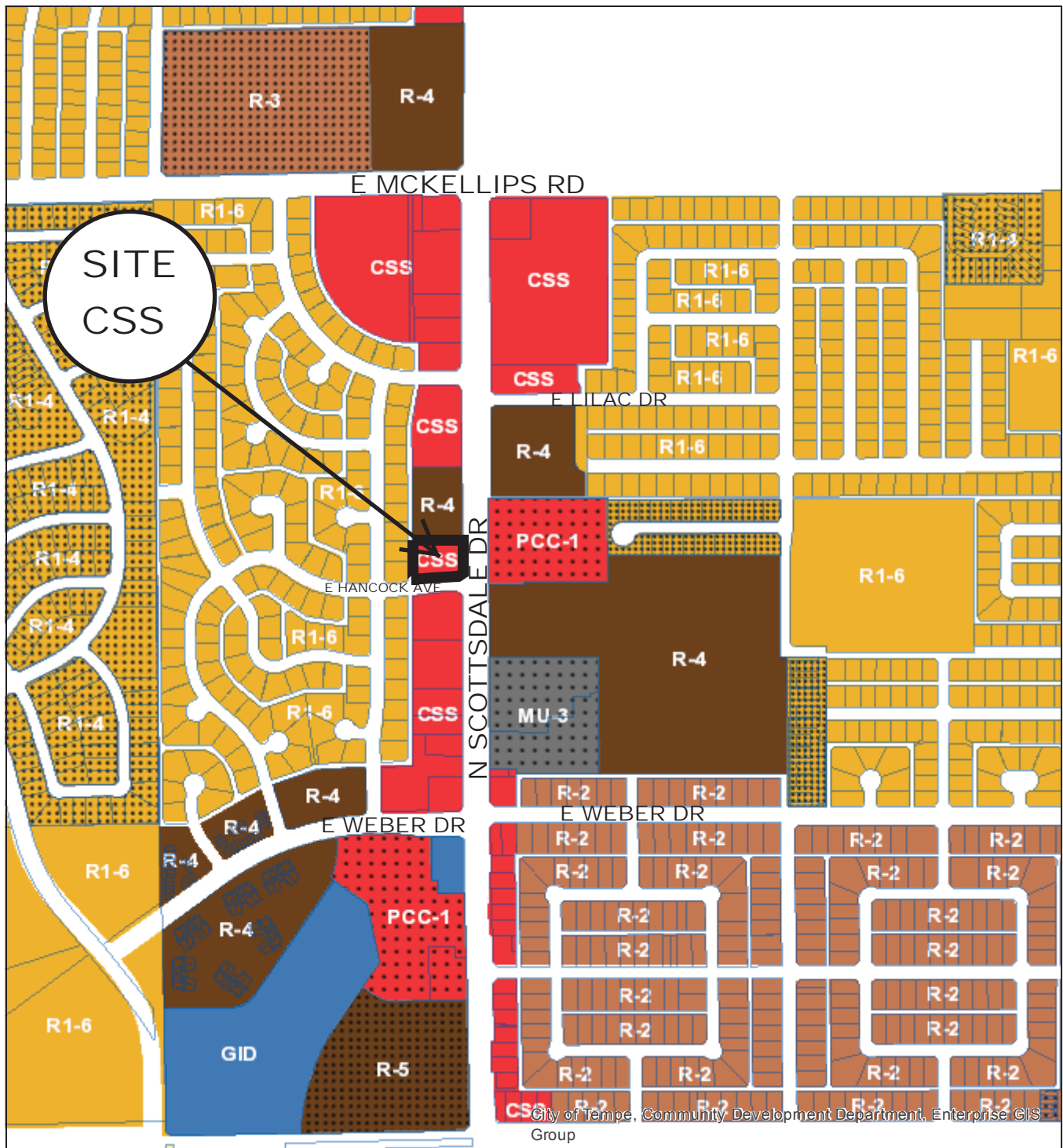



ATTACHMENTS:

- 1-6. Site Context (Location Map, Aerial, Site Cover Page and Existing Demolition and Proposed Utilities Site Plan, Aerial with Site Plan Overlay, and Site Photos)
- 7-10. Applicant's Letter of Explanation
- 11-12. Site Design (Site Plan and Landscape Plan)
- 13-21. Building Design (Floor Plan, Building Sections, Blackline/Color Elevations, Material Samples, Blackline/Color Street Elevations and Renderings)

HUMAN BEAN

PL 180354



- | | |
|--|---|
|  General Industrial District (GID) |  Single-Family Residential (R1-4) |
|  Mixed Use Med-High (MU-3) |  Single-Family Residential Planned Area Dev (R1-PAD) |
|  Commercial Shopping and Services (CSS) |  Multi-Family Residential (R-2) |
|  Planned Commercial Center Neighborhood (PCC-1) |  Multi-Family Residential Limited (R-3) |
|  Agricultural (AG) |  Multi-Family Residential General (R-4) |
|  Single-Family Residential (R1-6) |  Multi-Family Residential High (R-5) |

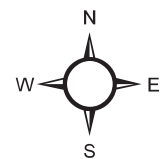

HUMAN BEAN

PL 180354



Aerial Map

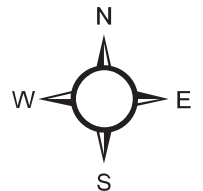

THE HUMAN BEAN

1602 N. SCOTTSDALE ROAD TEMPE, AZ 85281

PROJECT TEAM

CLIENT
SCOTTSDALE HANCOCK LLC
1602 N SCOTTSDALE RD
TEMPE, AZ 85260

OWNER
THE HUMAN BEAN OF ARIZONA, INC.
KIRIAN SHERRILL

ARCHITECT
ROSS DESIGN GROUP L.L.C.
4342 NORTH CIVIC CENTER PLAZA
SCOTTSDALE, ARIZONA 85251
CONTACT: DAVID ROSS STEVE SURGENER
602-908-7805
480-947-9685
480-429-0107
EMAIL: rdg@rossdesign.biz

CONSULTANT

ARCHITECTURAL CONSULTING ENGINEERS
CONTACT: MOHAMMAD ARDEBILI
8100 E INDIAN SCHOOL ROAD
SCOTTSDALE, AZ 85251
(602) 361-6269
EMAIL: mard@ardebiliengineering.com

ARCHITECTURAL PARTNERSHIP
CONTACT: KEVIN MOORE
414 S MILL AVENUE, SUITE 207
TEMPE, AZ 85281
(480) 894-9284
EMAIL: kmoore@kmoorestudio.com

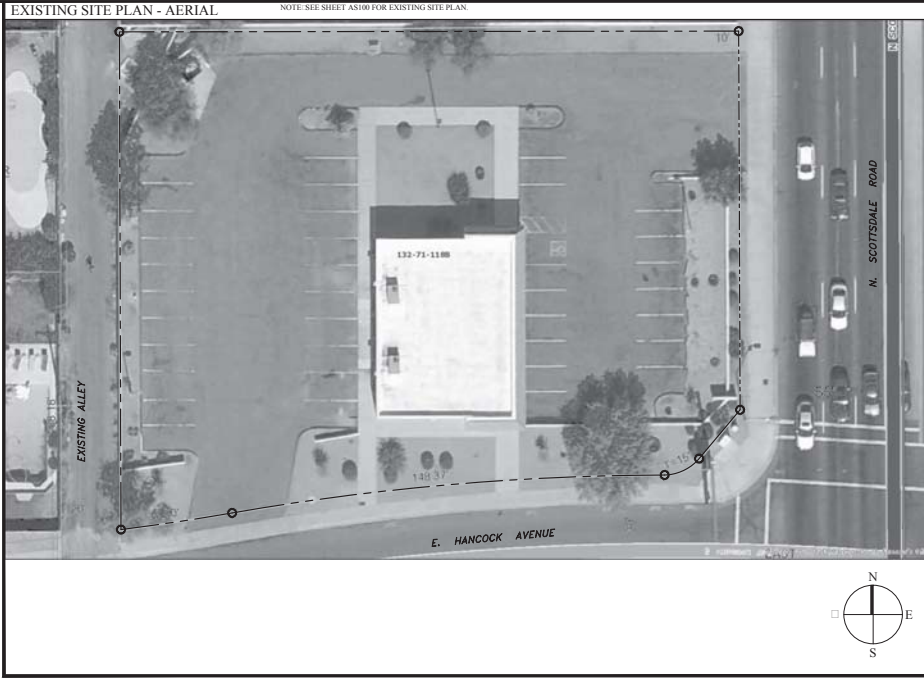

PROJECT DESCRIPTION
PROVIDE FOR A NEW LOCATION FOR A DRIVE-THRU COFFEE BUSINESS. SINGLE DRIVE-THRU ON AN EXISTING LOT. IMPROVEMENTS INCLUDE CONSTRUCTION OF NEW BUILDING, RELOCATING DRIVEWAY, RESURFACING EXISTING PARKING LOT, ADDING NEW LANDSCAPING AND CURBING.

PROJECT DATA
CLIENT: 6502 N 16TH ST LLC
CHRISTOPHER L ALTON
6502 N 16TH ST
PHOENIX AZ 85016
PROJECT ADDRESS: 1602 N SCOTTSDALE RD
TEMPE AZ 85281
APN: 132-71-118
LEGAL: CAVALIER HILLS UNIT 2 MCR
BOOK 90 OF MAPS, PAGE 44
S.T.R.: 10' IN : 4E
ZONING: CSS
CONSTRUCTION TYPE: V - SPRINKLERED
OCCUPANCY: U - USENESS
FIRE EXTINGUISHER: YES
BUILDING DATA:
BUILDING SF: 528 SF TOTAL
OVERHANGS: 384 SF TOTAL
124 SF DRIVE - THRU
260 SF COVERED SIDE - ALK
AREA UNDER ROOF: 1,412 SF TOTAL
BUILDING HEIGHT: 20'-0" A.F.F. 35'-0" ALLO - ED

SHEET INDEX

GENERAL	CVR	COVER SHEET, CODE INFORMATION
SITE	AS100	EXISTING DEMO UTILITIES SITE PLAN
	AS101	ARCHITECTURAL SITE PLAN
	AS200	AERIAL SITE PLAN OVERLAY
CIVIL	C1	COVER SHEET, PROJECT DATA, NOTES
	C2	GRADING AND DRAINAGE PLAN
LANDSCAPE	L1	LANDSCAPE PLAN
	ARCHITECTURAL	
ARCHITECTURAL	A400	EXTERIOR ELEVATIONS (24X36)
	A401	EXTERIOR ELEVATIONS - COLORED (14X17)
	A402	STREETSCAPE ELEVATIONS (24X36)
	A402	STREETSCAPE ELEVATIONS (24X36)

NOTE: SEE SHEET AS101 FOR PROPOSED SITE PLAN AND ZONING DATA, LOT COVERAGES AND CALCULATIONS.

OCCUPANCY CALCULATIONS

PER 1-C SECTION 1004.12 AND 1004.4 TABLE COUNT AT DINING AREA

OUTDOOR DINING AREA	196 SF AREA	13.06 OCCUPANTS
1 OCCUPANT PER 15 SF	196 SF 15	
ALK-UP ORDER AREA	30 SF AREA	2.00 OCCUPANTS
1 OCCUPANT PER 15 SF	30 SF 15	
TOTAL PATRONS:	TOTAL	15.06 OCCUPANTS
PREP / STAFF AREA	355 SF AREA	1.77 OCCUPANTS
1 OCCUPANT PER 200 SF	355 SF 200	
TOTAL OCCUPANTS:	ACTUAL	16.83
		17.00 OCCUPANTS
OUTDOOR ACCESSIBLE SEATING	14 X 5	70 OCCUPANTS
MINIMUM NUMBER OF REQUIRED PLUMBING FIXTURES (PER CHAPTER 29 TABLE 2902.1)		

	RE-URIED	UNISEX RESTROOM PROVIDED
MEN	1 PER 25 : 0.68 (1)	1 : 1 ATERCLOSET PROVIDED
WOMEN	1 PER 25 : 0.68 (1)	
	RE-URIED	PROVIDED
MEN	1 PER 40 : 0.42	1 LAVATORY PROVIDED
WOMEN	1 PER 40 : 0.42	

SERVICE SINK : 1 MOP SINK PROVIDED
PLUMBING FIXTURE REQUIREMENTS (PER CHAPTER 29)
USE GROUP : OCCUPANCY
17 TOTAL OCCUPANTS : 2 : 8 MEN : 8 : WOMEN

CURRENT ADOPTED CODES

THE FOLLOWING CODES AND THE CITY OF TEMPE AMENDMENTS THERE TO ARE ADOPTED PER ORDINANCE 02015.12:

2012 TEMPE BUILDING SAFETY ADMINISTRATIVE CODE	
2012 INTERNATIONAL ENERGY CONSERVATION CODE	
2012 INTERNATIONAL EXISTING BUILDING CODE	
2012 INTERNATIONAL BUILDING CODE	
2012 INTERNATIONAL MECHANICAL CODE	
2011 NATIONAL ELECTRICAL CODE	
2012 INTERNATIONAL PLUMBING CODE	
2012 INTERNATIONAL FUEL GAS CODE	
2012 INTERNATIONAL FIRE CODE	
FIRE SPRINKLER SYSTEM DESIGN:	NFPA 13 2010 EDITION NFPA 13R 2010 NFPA 13D 2010
FIRE ALARM SYSTEM DESIGN:	NFPA 72 2010 NEC/NFPA 70 2011 EDITION

DEFERRED SUBMITTALS

FIRE SPRINKLER SYSTEM:
FIRE SPRINKLER SYSTEM DESIGN AND CONSTRUCTION DOCUMENTS WILL BE SUBMITTED AS A DEFERRED SUBMITTAL BY THE SYSTEM INSTALLER AND HIS FIRE PROTECTION ENGINEER.

FIRE ALARM SYSTEM:
CLASS A FIRE ALARM SYSTEM DESIGN AND CONSTRUCTION DOCUMENTS WILL BE SUBMITTED AS A DEFERRED SUBMITTAL BY THE SYSTEM INSTALLER AND HIS FIRE PROTECTION ENGINEER AS A DEFERRED SUBMITTAL BY THE SYSTEM INSTALLER AND HIS FIRE PROTECTION ENGINEER (IF REQUIRED).

AUTOMATIC SPRINKLER SYSTEM IS A DEFERRED SUBMITTAL.

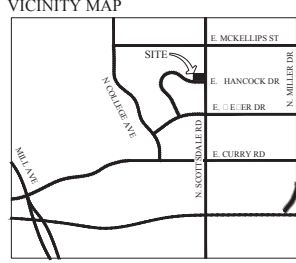

ROSS DESIGN GROUP L.L.C.
ARCHITECTURE INTERIORS PLANNING PROJECT MANAGEMENT
4342 NORTH CIVIC CENTER PLAZA
SCOTTSDALE, ARIZONA 85251
PHONE: (480) 947-9685
FAX: (480) 429-0107
www.rossdesign.biz

REVISIONS

THE HUMAN BEAN COFFEE
1602 N. SCOTTSDALE ROAD
TEMPE, AZ 85281

DEVELOPMENT PLAN REVIEW

APPROVED FOR THE CITY OF TEMPE

27919
JAMES STEPHEN SUDGEMER
PLUMBING ENGINEER

DATE: 11-16-2016 SHEET NO:
SCALE: AS SHOWN
DESIGNED BY: CVR
CHECKED BY: DAVID ROSS

COVER SHEET

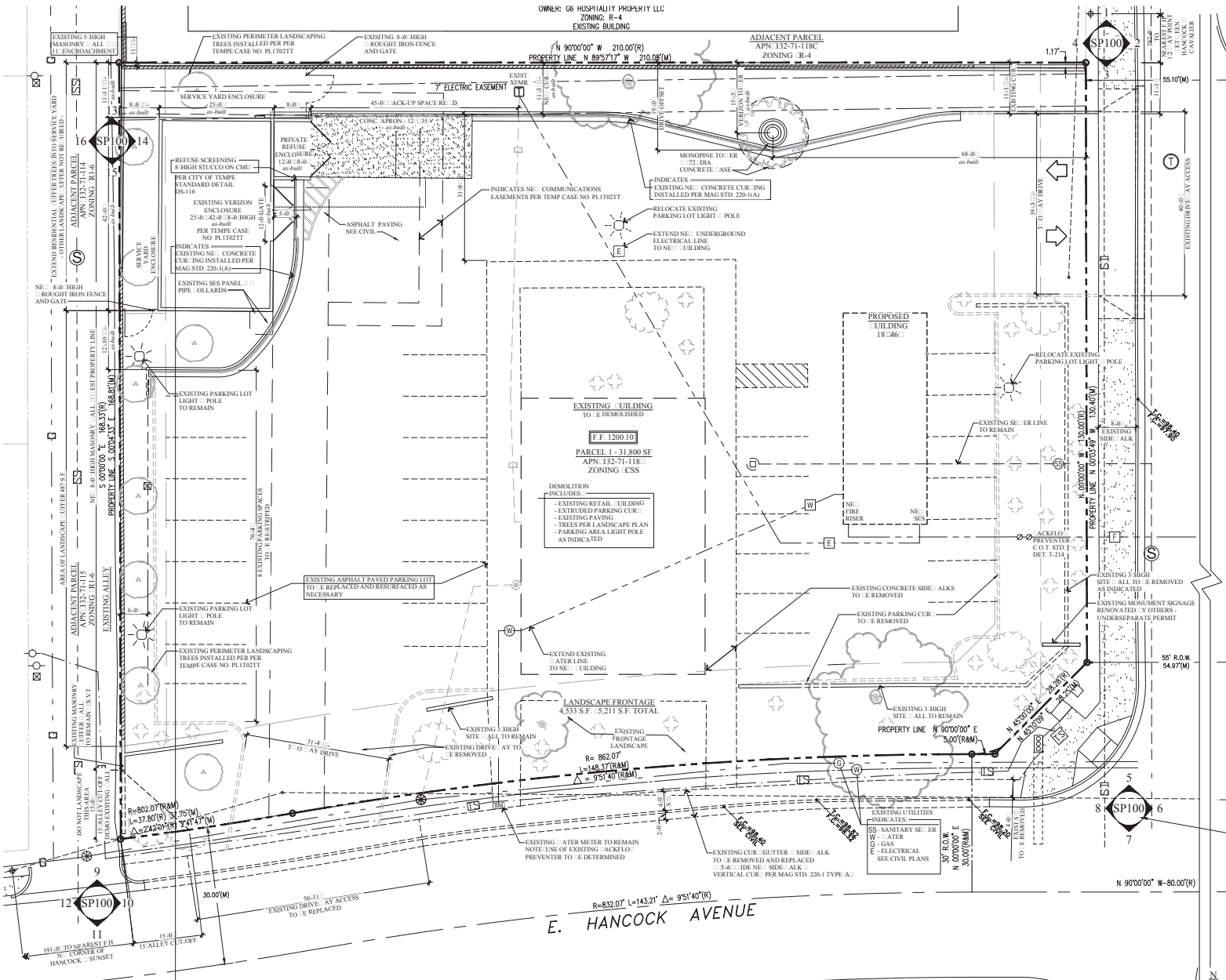

- DEMOLITION NOTES**
- CONTRACTOR SHALL BE RESPONSIBLE FOR:
 - VERIFY ALL DIMENSIONS AND CONDITIONS PRIOR TO STARTING WORK. NOTIFY BROS DESIGN GROUP OF DISCREPANCIES OR INCONSISTENCIES.
 - VERIFY IN FIELD ALL EXISTING CONDITIONS SHOWN ON DRAWINGS. VERIFY ALL DIMENSIONS WITH THE ARCHITECTURAL DRAWINGS.
 - CONTRACTOR SHALL LOCATE ALL ON SITE EXISTING UTILITIES PRIOR TO ANY WORKING PERFORMED. CONTACT THE STATE AND ALL OTHER UTILITY COMPANIES PRIOR TO START OF DEMOLITION.
 - PROVIDE ALL MEASURES NECESSARY TO PROTECT EXISTING STRUCTURES DURING CONSTRUCTION. SUCH MEASURES SHALL INCLUDE, BUT NOT LIMITED TO, BRACING AND SHORING FOR LOADS IMPOSED DURING CONSTRUCTION, ETC.
 - OPTIONS ARE FOR THE CONTRACTOR'S CONVENIENCE. HE SHALL BE RESPONSIBLE FOR ALL CHANGES NECESSARY IF HE CHOOSES AN OPTION AND SHALL COORDINATE ALL DETAILS.
 - PROVIDE ALL MEASURES NECESSARY DURING DEMOLITION TO PROTECT ALL ELEMENTS TO REMAIN. SUCH MEASURES SHALL INCLUDE, BUT NOT LIMITED TO, BRACING AND SHORING FOR LOADS IMPOSED DURING CONSTRUCTION, ETC.
 - GENERAL CONTRACTOR IS TO CONSULT THE OWNER ON SITE OR HERE TO STORE ITEMS FOR THE RE-USE OF MATERIALS BY OWNER/ TENANT.
 - CHECK CONDITION OF CURB AND SIDEWALK ADJACENT TO PROPERTY FOR POSSIBLE REPLACEMENT OR IMPROVEMENT. ENGINEERING INSPECTOR WILL CHECK FOR THIS DURING CONSTRUCTION.

ROSS DESIGN GROUP L.L.C.
 ARCHITECTURE INTERIORS PLANNING PROJECT MANAGEMENT
 4330 GLENVIEW CENTER BLVD
 PHOENIX, AZ 85018
 P: (480) 444-8888 FAX: (480) 444-9007
 www.rossdesigngroup.com

REVISIONS

THE HUMAN BEAN COFFEE
 1602 N. SCOTTSDALE ROAD
 TEMPE, AZ 85281

DEVELOPMENT PLAN REVIEW

SEAL AND SIGNATURE OF REVIEWER

NOTE: INDICATES KEY TO PROPERTY LINE CONTEXT PHOTOS - SEE SHEET SP100

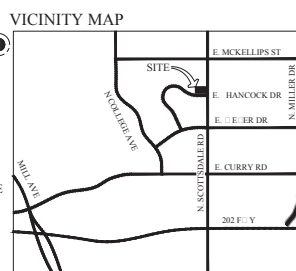

EXISTING DEMOLITION PROPOSED UTILITIES SITE PLAN GRAPHIC SCALE 10 10 15 20 SCALE: 1"=10'-0"

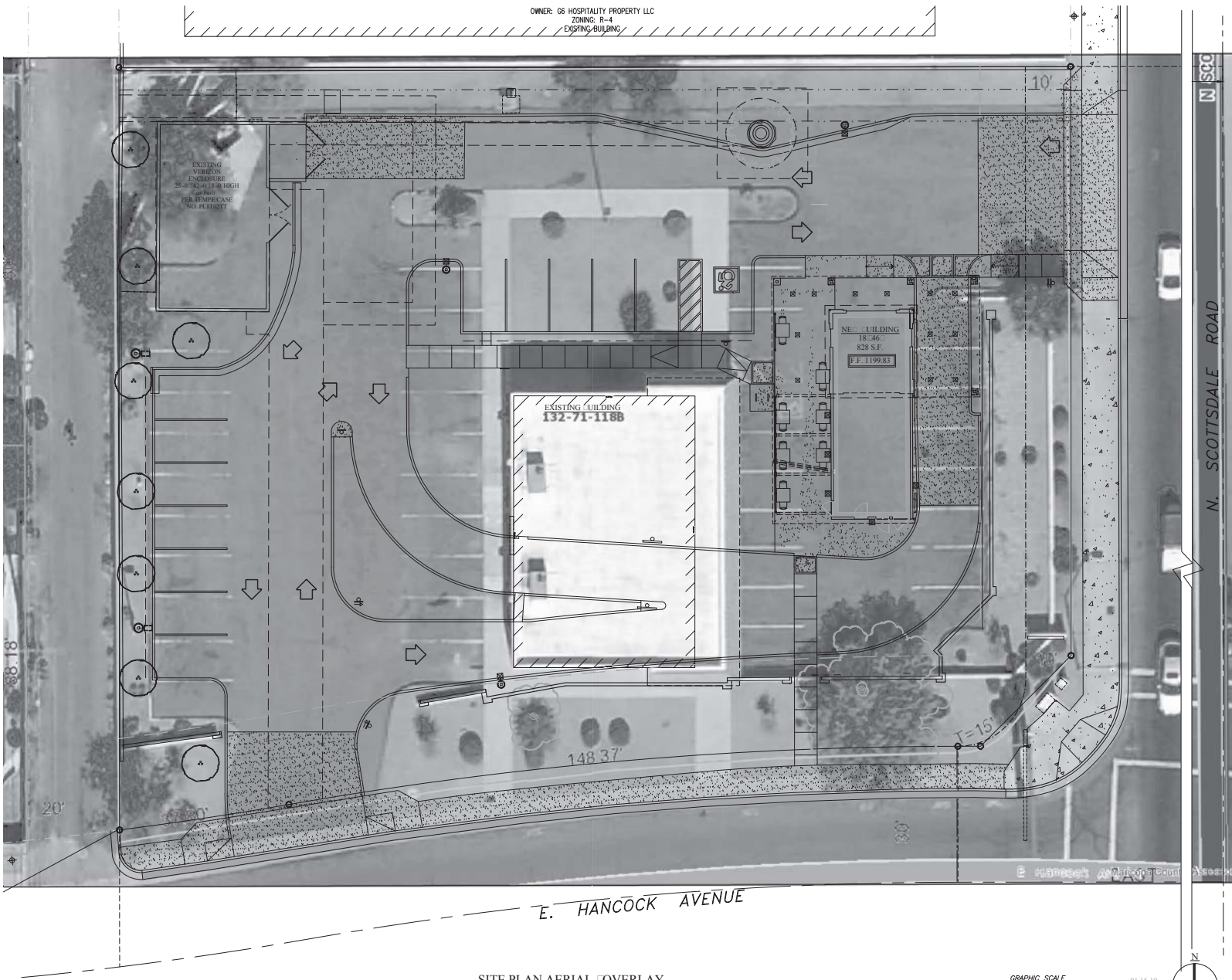

OWNER: GS HOSPITALITY PROPERTY LLC
 ZONING: R-4
 EXISTING BUILDING

EXISTING VERZON ENCLOSURE
 25'0" TALL 18" HIGH
 100' x 100'
 PER TEMPE CASE NO. PL10421

EXISTING BUILDING
 132-71-1188

NEW BUILDING
 18-46
 828 S.F.
 P.F. 119983

E. HANCOCK AVENUE

N. SCOTTSDALE ROAD

SITE PLAN AERIAL OVERLAY

- NOTE:
- REFER TO SHEET AS101 FOR SITE DEVELOPMENT NOTES, DIMENSIONS AND DATA.
 - THIS PLAN PROVIDED FOR SCHEMATIC OVERLAY PURPOSES ONLY.



ROSS DESIGN GROUP L.L.C.
 ARCHITECTURE INTERIORS PLANNING PROJECT MANAGEMENT
 4335 CIVIC CENTER PLAZA
 P.O. BOX 104000 TAMPA, FL 33610
 TEL: (813) 281-1100 FAX: (813) 281-9907
 www.rossdesignllc.com

REVISIONS

THE HUMAN BEAN COFFEE
 1602 N. SCOTTSDALE ROAD
 TEMPE, AZ 85281

DEVELOPMENT
 PLAN
 REVIEW

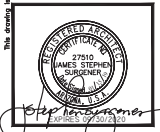

DATE: 01-15-10 SHEET NO:
 SCALE: AS SHOWN
 DESIGNED BY: AS 2000
 CHECKED BY: DAVID BOSS
AS200
 SITE AERIAL OVERLAY

LETTER OF EXPLANATION

Project: 1602 N. Scottsdale Rd, Tempe, Arizona
Parcel #: 132-71-118B
Project: The Human Bean Coffee / Drive thru with Patio
DS#: 180712
PL#: 180354

We are proposing to redevelop the site located at 1602 N. Scottsdale Road. The scope of work improvements involve: construction of a new building, with outdoor patio area, site work, landscaping and civil work, with adequate parking and stacking for single lane drive thru. Currently there is a Verizon project in the city reflecting a new location for a cell tower. Our plan matches their most recent, located 68 feet west of the east property line, along the northern part of the site. It is located on our site plan matching the Verizon plans.

The Human Bean is a regional coffee chain from the Pacific Northwest, which has a few stores open in the Valley. One is in Phoenix and one is operational in Mesa, as well as Tempe at University and McClintock. The concept is a drive thru only coffee operation with a patio and walk up window as well. There are 3 employees per shift; hours 5:00 am – 8:00 pm.

Design Criteria for Development Plan Review

As outlined in ZDC Section 6-306 D:

1. Placement, form, and articulation of buildings and structures provide variety in the streetscape: The building is placed toward the front of the site along Scottsdale Road in order to attract customers. The site walls are placed in front of the building along with adequate trees and landscaping creating variety in the streetscape.
2. Building design and orientation, together with landscape, combine to mitigate heat gain/retention while providing shade for energy conservation and human comfort: The site is articulated with plenty of trees, which shade the site, drive through and along Scottsdale road, creating plenty of shade for the building and customers. In addition the outdoor patio seating has a built in shade structure. Also west of the patio, turf is incorporated for a nice comprehensive shaded environment to enhance a cooling effect.
3. Materials are of a superior quality, providing detail appropriate to their location and function while complementing the surroundings: The finishes and stonework on the site walls and the building add a superior quality to the site. The building finishes can be reviewed on the color renderings, indicating a nice paint scheme along with signage and stone which has been reviewed by the planning staff, whom also requested stone end caps on the site walls abutting Scottsdale Road and Hancock Road. The Human Bean corporate scheme and finishes are established and followed for the building materials.
4. Buildings, structures, and landscape elements are appropriately scaled, relative to the site and surroundings: The building scale along with built in shade canopies over the drive thru window along Scottsdale road, and the seating patio to the west, help put the building in proper scale. Landscape has been scrutinized by city staff and our landscape architect to achieve an upscale look and environment for the site.
5. Large building masses are sufficiently articulated so as to relieve monotony and create a sense of movement, resulting in a well-defined base and top, featuring an enhanced pedestrian experience at and near street level: The building colored elevations and site renderings indicate the variety of paint finishes and materials enhancing the building and shade structures, along with stone along the lower part of the building and an upscale presentation at the main high portion of the building articulated with a stone finish. Sidewalks from both street sides tie pedestrians into the site to the building, encouraging neighborhood enjoyment.
6. Building facades provide architectural detail and interest overall with visibility at street level (in particular, special treatment of windows entries and walkways with particular attention to proportionality, scale, materials, rhythm, etc.) while responding to varying climatic and contextual conditions; Mentioned in items 1 thru 5 above. Also review attached drawing set for full articulation of the site. Shade structures, paint scheme, moldings and stone add to the variety and interest of the building area. Sidewalks accommodate ADA access, along with clear access to and from both streets

including sidewalk along Scottsdale Road, linked to public transportation. Site walls screen the drive thru traffic, painted to match the building base paint color, coupled with stone ends on the low walls, the same stone finish tying to the building. This will create variety, interest and rhythm of site and building material integration.

7. Plans take into account pleasant and convenient access to multi-modal transportation options and support the potential for transit patronage; Sidewalks accommodate ADA access, along with clear access to and from both streets including sidewalk along Scottsdale Road, linked to public transportation.
 8. Vehicular circulation is designed to minimize conflicts with pedestrian access and circulation, and with surrounding residential uses: Site circulation accommodates access from both Scottsdale Road and Hancock Road. The site is large enough to handle oversized stacking, the largest site ever built on by Human Bean. There is 200 feet of stacking in the immediate drive thru lane, coupled with driveway site circulation to the north side of Scottsdale, accommodating another 100 feet. No conflicts arise from the driveway access or the sidewalks along Scottsdale Road and Hancock, which are unobstructed. The owner is making great expenditures in materials, stone end caps on walls, overabundance of landscaping, and parking, which helps in minimizing any impact off the site.
 9. Plans appropriately integrate *Crime Prevention Through Environmental Design* principles such as territoriality, natural surveillance, access control, activity support, and maintenance; The CPTED principles have been reviewed by staff and efforts have been made to comply. Site lighting is per the city ordinance, sidewalks and driveways well lit, along with the outdoor patio area which has adequate lighting, coupled with security cameras under the canopies for staff surveillance on constant T.V. screens inside the staff area, to assist in crime prevention.
 10. Landscape accents and provides delineation from parking, buildings, driveways and pathways: Landscaping has been scrutinized by city staff, to ensure the ordinance is being complied with. All areas all well delineated and separated by landscape between the building, patio, driveways and parking.
 11. Signs have design, scale, proportion, location and color compatible with the design, colors, orientation and materials of the building or site on which they are located: Signage is a corporate identity, which has regional recognition of the brand, and has been well articulated, studied and integrated into the building elevations.
 12. Lighting is compatible with the proposed building(s) and adjoining buildings and uses, and does not create negative effects: Lighting is per City of Tempe ordinance providing adequate site lighting, without impacting adjacent sites per the code. No negative effects are created by the site lighting as indicated in the drawings. There is nice buffer from the alley located at the west end of the property, creating a separation from the single family residential to the west.
-
1. The development fulfills certain goals and objectives in the General Plan, and the principles and guidelines of other area policy plans. Performance considerations are established to fulfill those objectives. The project is in compliance with all Tempe zoning guidelines.
 2. Standards requested through the PAD Overlay District shall take into consideration the location and context for the site for which the project is proposed: The project is in compliance with all Tempe building finish and standards guidelines.
 3. The development appropriately mitigates transitional impacts on the immediate surroundings. The project provides adequate driveway entrance and exits along Scottsdale and Hancock. The lot is deep and accommodates more than required stacking for drive-thru traffic. Drive-thru is located toward front of property where the order window is along Scottsdale Road, in which any sound will be over shadowed by traffic noise. Scottsdale road a major arterial will drown out the mitigate noise created at the window . This Human Bean location is enacting a program where orders are taken via staff with an I Pad at the cueing line. There is a menu board in the cue line, a staff member takes the order from the drive thru patron at their car window, the order travels via wireless to the staff inside the building. There is no additional noise created from a call box.

USE PERMIT CRITERIA FOR DRIVE-THRU (per section 6-308-E)

Background:

The size of the lot is more than adequate for the coffee drive thru use proposed. The open space and landscape is proposed at 35% of the net lot area. The existing building and lot has 38 parking spaces, with significant less landscape area. If the site were developed as an adaptive re-use than the same number of parking spaces could have been retained at 38 spaces. The Human Bean plan has a net reduction of 24 spaces. The proposed site has a total of 14 parking spaces, 7 required, 4 for staff use and 3 allowed for 450 s.f. of outdoor picnic style seating in our larger open space amenity located west of the outdoor patio. By redeveloping the site it triggered the ordinance for a reduction in parking. Our goal in asking for the request of excess parking is to be able to control parking on site, which will accommodate 4 staff parking spaces without having the need to park off site. This encourages all on site parking, and controls traffic along hancock road in and out of the site, directly exiting back to Scottsdale road, without the need to travel west into the residential area. We see our proposed parking request for additional spaces as a positive one, that encourages being a good neighbor, with all on site parking.

This Human Bean location is enacting a program where orders are taken via staff with an I Pad at the cueing line. There is a menu board in the cue line, a staff member takes the order from the drive thru patron at their car window, the order travels via wireless to the staff inside the building. There is no additional noise created from a call box.

- A. Any significant vehicular or pedestrian traffic in adjacent areas:
The proposed business will support the General Plan by provided easy pedestrian, auto and business access from Scottsdale Rd and Hancock. ADA sidewalks landscaped with native adapted plants guide pedestrians safely from busy street to location. The drive-thru has been planned to allow for stacking of over 200 feet. This allows for not placing a burden on surrounding businesses to adequately control the drive thru.
- B. Nuisance arising from the emission of odor, dust, gas, noise, vibration smoke, heat or glare at a level exceeding that of ambient conditions:
The proposed business type will not create any noticeable amount of nuisance of the above listed items. Screen walls and landscape along Scottsdale and Hancock provide adequate screening, buffering of noise, heat, and glare. This Human Bean location is enacting a program where orders are taken via staff with an I Pad at the cueing line. There is a menu board in the cue line, a staff member takes the order from the drive thru patron at their car window, the order travels via wireless to the staff inside the building. There is no additional noise created from a call box. Also the traffic noise along Scottsdale Road should adequately drown out all noise during the normal business day. (Scottsdale Road, major arterial approximating over 20,000 trips per day)
- C. Contribution to the deterioration of the neighborhood or to the downgrading of property values, which is conflict with the goals, objectives or policies of the city's adopted plans for General Plan:
The proposed business supports the General Plan by providing community access to The Human Bean coffee location. The sidewalks on each street side, encourages neighborhood pedestrian traffic, with nice landscaping and shade. The outdoor patio allows for a nice environment abutting a turf area with a tree buffer for noise and shade. This site layout accommodates the ordinance criteria well. Currently 35% landscaped / open space is provided on the net site. The operator of The Human Bean is interested in working with the neighborhood to have good relationships and encourage their interest and business as well.
- D. Compatibility with existing surrounding structures and uses:
The proposed business aesthetic is visually aligned with the neighborhood in character, finishes and scale. The building is nicely detailed and apportioned with finishes, colors, stone enhancement, site walls and landscaping for proper scale and incorporates well into the surrounding area. Renderings are part of the submittal package.
- E. Adequate control of disruptive behavior both inside and outside the premises, which may create a nuisance to the surrounding area or general public. The proposed business is a coffee drive thru, with an over-abundance of landscaping, abutting an outdoor patio for the general public, with pedestrian access from both streets. The building and drive thru window is positioned furthest east along Scottsdale road to control noise and the majority of site activity. This was thought about during the planning process. With coffee only being served there should be no disruptive behavior inside or outside the premises.

USE PERMIT CRITERIA FOR PARKING IN EXCESS OF ALLOWED MAXIMUM

Background:

The size of the lot is more than adequate for the coffee drive thru use proposed. The open space and landscape is proposed at 35% of the net lot area. The existing building and lot has 38 parking spaces, with significant less landscape area. If the site were developed as an adaptive re-use than the same number of parking spaces could have been retained at 38 spaces. The Human Bean plan has a net reduction of 24 spaces. The proposed site has a total of 14 parking spaces, 7 required, 4 for staff use and 3 allowed for 450 s.f. of outdoor picnic style seating in our larger open space amenity located west of the outdoor patio. By redeveloping the site it triggered the ordinance for a reduction in parking. Our goal in asking for the request of excess parking is to be able to control parking on site, which will accommodate 4 staff parking spaces without having the need to park off site. This encourages all on site parking, and controls traffic along hancock road in and out of the site, directly exiting back to Scottsdale road, without

the need to travel west into the residential area. We see our proposed parking request for additional spaces as a positive one, that encourages being a good neighbor, with all on site parking.

This Human Bean location is enacting a program where orders are taken via staff with an iPad at the cueing line. There is a menu board in the cue line, a staff member takes the order from the drive thru patron at their car window, the order travels via wireless to the staff inside the building. There is no additional noise created from a call box.

A. Any significant vehicular or pedestrian traffic in adjacent areas; The proposed business will support the General Plan by provided easy pedestrian, auto and bus access from Scottsdale Rd and Hancock. ADA sidewalks landscaped with native adapted plants guide pedestrians safely from busy street to location. The drive-thru has been planned to allow for stacking of over 200 feet. This allows for not placing a burden on surrounding businesses. Additionally The Human Bean owner is finding from other locations, that having 3 to 4 employee parking spaces on site is the model for not encouraging any off street parking; Thus not encouraging any offsite parking to impact adjacent streets, businesses or residential adjacencies.

B. Nuisance arising from the emission of odor, dust, gas, noise, vibration smoke, heat or glare at a level exceeding that of ambient conditions:

The proposed business type will not create any noticeable amount of nuisance of the above listed items. Screen walls and landscape along Hancock and an 8 foot wall along the west alley, provide more than adequate screening, buffering of noise, heat, and glare for the excess 4 parking spaces for staff.

C. Contribution to the deterioration of the neighborhood or to the downgrading of property values which is conflict with the goals, objectives, or policies of the cities adopted plans for General Plan:

The proposed excess parking of 4 spaces for staff parking would enhance this guideline principle. By having the additional parking for staff all parking on site is assured, which would support this guideline to enhance property values. The impact is a positive one.

D. Compatibility with existing surrounding structures and uses:

The proposed business aesthetic is visually aligned with the neighborhood in character, finishes and scale.

E. Adequate control of disruptive behavior both inside and outside the premises, which may create a nuisance to the surrounding area or general public. The proposed business is a coffee drive thru, with an over-abundance of landscaping, abutting an outdoor patio for the general public, with pedestrian access from both streets. The building and drive thru window is positioned furthest east along Scottsdale road to control noise and the majority of site activity. This was thought about during the planning process.

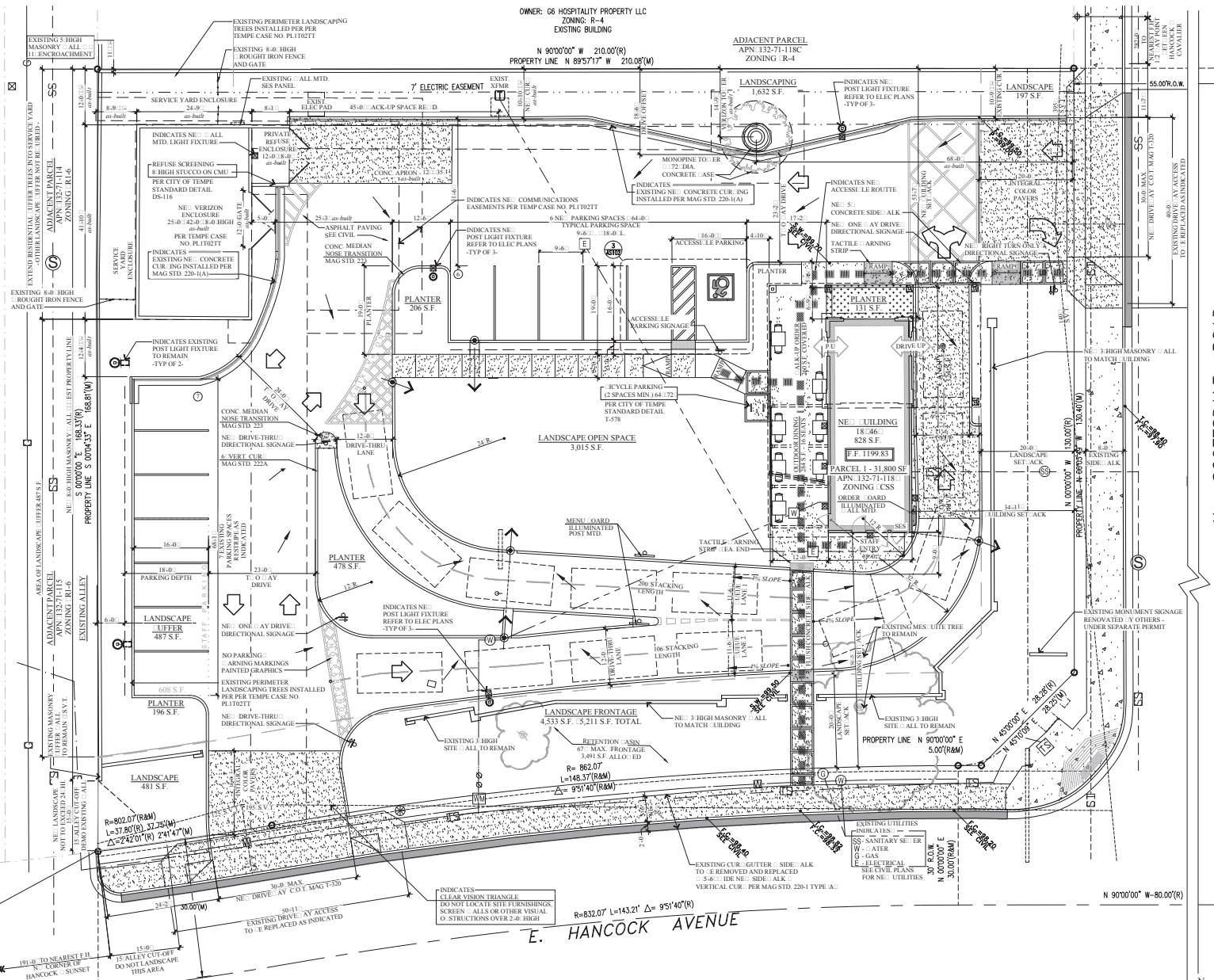

PROJECT DESCRIPTION

PROVIDE FOR A NEW LOCATION FOR A DRIVE-THRU COFFEE BUSINESS SINGLE DRIVE-THRU ON AN EXISTING LOT. IMPROVEMENTS INCLUDE CONSTRUCTION OF NEW BUILDING, RELOCATING DRIVEWAYS, RESURFACING EXISTING PARKING LOT, ADDING NEW LANDSCAPING AND CURBING.

PROJECT DATA

CLIENT:	682 N 14TH ST LLC CHRISTOPHER L ALTON 682 N 14TH ST PHOENIX, AZ 85006
PROJECT ADDRESS:	1602 N SCOTTSDALE RD TEMPE AZ 85281
APN:	132-71-118C
LEGAL:	CAVARIER HILLS UNIT 2 MCR BOOK 90 OF MAPS, PAGE 44
S.T.R.:	10-1N-4E
ZONING:	CSS
CONSTRUCTION TYPE:	VL- NON SPINKLERED
OCCUPANCY:	U- BUSINESS
FIRE EXTINGUISHER:	YES
BUILDING DATA:	828 SF TOTAL 324 SF RESTAURANT 266 SF COVERED SIDE: ALK
OVERHANGS:	848 SF TOTAL 324 SF RESTAURANT 266 SF COVERED SIDE: ALK
AREA UNDER ROOF:	1,412 SF TOTAL
BUILDING HEIGHT:	20'-0" A.F.F. 35'-0" ALLO: ED
SOIL DATA:	
LOT SIZE:	31,800 SF NET
BUILDING AREA:	828 SF RESTAURANT 1,050 SF OVERZON YARD 1,878 SF (INCLUDING VERZON)
LOT COVERAGE:	2.6: THIS PROJECT 5.9: (INCLUDING VERZON)
LANDSCAPE AREA:	5,211 SF FRONTAGE 5,939 SF INTERIOR LOT 11,150 SF TOTAL
LANDSCAPE PERCENT:	35: OF NET LOT 11,150 SF 31,800
RE-USED SET-ACKS:	C.O.T SEC 203A (CSS)
FRONT:	0'-0" 20'-0" PARKING
SIDE:	0'-0" BUILDING - ALL 0'-0" COMMON - ALL
REAR:	10'-0" BUILDING - ALL 0'-0" 20'-0" PARKING
PARKING RE-USEMENTS:	C.O.T SEC 4603E
RESTAURANT:	284 SF 3000 @ 9 SPACES 828 SF 1500 @ 6 SPACES TOTAL PARKING RE-USED: 11 SPACES
MAX PARKING ALLOWED:	4 SP 125 @ 6 SPACES PARKING PROVIDED: 11 SPACES
STALL SIZE PROVIDED:	19'-6" @ 18'-0" L ACCESSIBLE PARKING: 1 C.T.A.L.E. 106'
BI-CYCLE PARKING RE-USED:	(2-00) @ (6-00) L
RESTAURANT:	284 SF 3000 @ 9 SPACES 828 SF 2000 @ 1 SPACE PROVIDED: 2 SPACES
EXITS:	1 RE-USED - 1 PROVIDED
TOILET ROOMS:	1 UNISEX TOILET RE-USED 1 PROVIDED
OCCUPANCY:	11 OCC
USE PERMITS RE-USED:	DRIVE-THRU PERMIT OUTDOOR DINING EXCESS PARKING

CITY OF TEMPE PLAN NOTES

1. ALL EQUIPMENT AND UTILITIES SHALL CONFORM WITH ALL APPLICABLE CODES AND ORDINANCES.
2. THIS PROJECT IS LOCATED IN THE CITY OF TEMPE, AFTER SEVERAL AREA AND HAS BEEN DEDICATED AS HAVING AN ASSURED WATER SUPPLY.
3. ALL NEW OR RELOCATED UTILITIES SHALL BE PLACED UNDERGROUND.
4. ALL SIGNAGE REQUIREMENTS SEPARATE APPROVALS AND PERMITS.
5. ANY LIGHTING SHALL BE PLACED SO AS TO DIRECT LIGHT AWAY FROM THE ADJACENT RESIDENTIAL PROPERTY AND SHALL NOT EXCEED ONE FOOT CANDLE AT THE PROPERTY LINE. NO MASH OR OBSCURE LIGHTING SHALL BE PERMITTED THAT EXCEEDS THE GENERAL LEVEL OF NOISE, ODOOR OR VIBRATION.
6. OWNERS OF THE PROPERTY ADJACENT TO PUBLIC RIGHT OF WAY SHALL BE RESPONSIBLE FOR MAINTAINING ALL LANDSCAPING WITHIN THE RIGHTS-OF-WAY IN ACCORDANCE WITH APPROVED PLANS.
7. TRAFFIC CALMING DEVICES SHALL BE PROVIDED UNLESS OTHERWISE APPROVED BY THE FIRE CODE OFFICIAL.
8. UTILITY ERECTION WORK SHALL BE FINISHED IN A NEUTRAL COLOR OR PAINT TO MATCH THE EXISTING COLORS. APPROVAL THAT COMPLEMENTS THE UTILITY COLORS.
9. ILLUMINATE BUILDING ENTRANCES AND HIDDEN AREAS TO ASSIST THE VISUAL ABILITY OF VISITORS FROM DARK TO DAY. REFER TO THE CITY OF TEMPE LIGHTING ORDINANCES FOR THESE LOCATIONS.
10. FIRE APPARATUS ACCESS ROADS SHALL HAVE A CLEAR HEIGHT OF 10 FEET. FIRE APPARATUS SHALL HAVE A CLEAR HEIGHT OF 10 FEET. FIRE APPARATUS SHALL HAVE A CLEAR HEIGHT OF 10 FEET.

VICINITY MAP

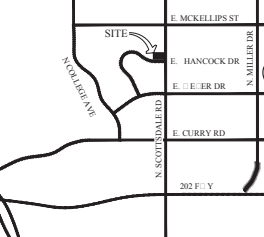

- ACCESSIBILITY KEYNOTES**
1. PROVIDE ACCESSIBLE ROUTE FROM ROAD AND ACCESSIBLE PARKING TO ALK UP SERVICE: INDOOR AND RESTROOM WITHIN.
 2. PROVIDE ALTERNATIVE PAVING WITHIN PARKING LOT.
 3. INCLUDE ACCESSIBLE PATH AS INDICATED ON SITE PLAN.
 4. PASSAGEWAYS THROUGH BUILDINGS, DOORS, POOR HAD, AREAS AND RESTROOM FACILITIES SHALL CONFORM TO THE REQUIREMENTS OF ARIZONA REVISED STATUTES, SECTIONS 34-401 THROUGH 34-411.
 5. CURB RAMP TO COMPLY WITH ANSI A117.1 SEC 4.7

- DEVELOPMENT SITE PLAN - DD11**
- NOTE:
- LANDSCAPE PLAN IS CONCEPTUAL. ACTUAL LOCATIONS TO BE PROVIDED WITH FULL LANDSCAPE DRAWINGS AFTER PRELIMINARY SITE PLAN REVIEW IS COMPLETED BY THE CITY.
 - GENERAL CONTRACTOR TO COORDINATE WITH EXISTING IRRIGATION SYSTEM ALREADY IN PLACE.
 - ARTERIAL STREET TREES SHALL BE A MINIMUM OF 36" COX SPECIMENS AND A MINIMUM OF 1 1/2" CALIPER TRUNK.

ROSS DESIGN GROUP L.L.C.
ARCHITECTURE INTERIORS PLANNING PROJECT MANAGEMENT

4001 GLENVIEW CENTER BLVD
PHOENIX, AZ 85018
PH: (480) 948-7440 FAX: (480) 948-9007
www.rossdesigngroup.com

REVISIONS

NO.	DATE	DESCRIPTION

THE HUMAN BEAN COFFEE
1602 N. SCOTTSDALE ROAD
TEMPE, AZ 85281

DEVELOPMENT PLAN REVIEW

APPROVED BY: [Signature]

DATE: 01-24-2024 SHEET NO: 17510

SCALE: AS SHOWN

DESIGNED BY: AS101

CHECKED BY: DAVID BOSS

NEW SITE PLAN

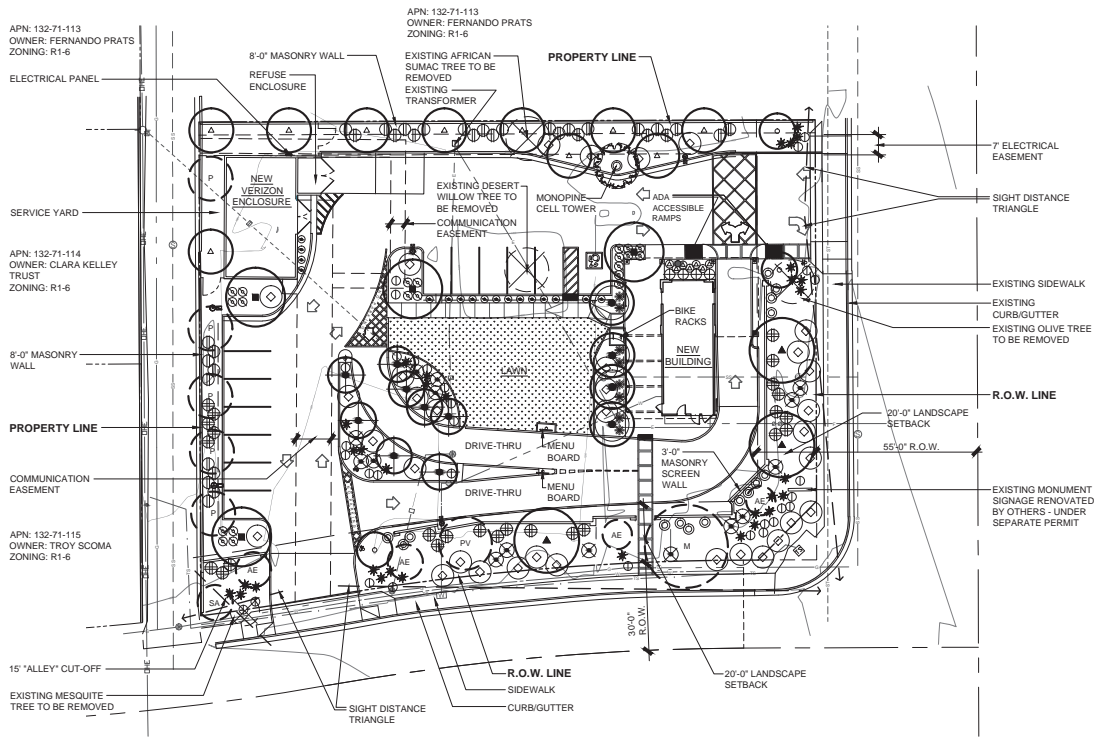

APN: 132-71-113
OWNER: FERNANDO PRATS
ZONING: R1-6

APN: 132-71-114
OWNER: CLARA KELLEY TRUST
ZONING: R1-6

APN: 132-71-115
OWNER: TROY SCOMA
ZONING: R1-6

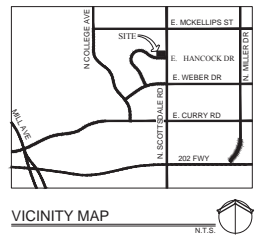

PLANT LIST

SYMBOL	BOTANICAL NAME COMMON NAME	SIZE AT PLANTING	QTY.	SIZE AT MATURITY	REMARK
TREES:					
○	ACACIA ANEURA MULGA	36" BOX 7-9HX4-6WX1.5" CAL.	3	20HX15'W	
○	ACACIA WILLARDIANA PALO BLANCO	24" BOX 5-8HX2.5-3.5WX1" CAL.	4	20HX15'W	
○	CAESALPINIA CACALACO 'SMOOTHIE' THORNLESS CASCALOTE	24" BOX 5-8HX3-4WX1" CAL.	8	15HX15'W	
○	PARKINSONIA PRAEOX SONORAN PALO VERDE	36" BOX 5-8HX4-5WX1.5" CAL.	3	25HX25'W	
○	PINUS ELДАРICA MONDELL PINE	24" BOX 7-9HX3-4WX1.5" CAL.	10	40HX30'W	
○	PROSOPIS THORNLESS HYBRID 'AZT' AZT THORNLESS MESQUITE	36" BOX 8-10HX7-8WX1.75" CAL.	4	30HX30'W	
SHRUBS:					
○	AMBROSIA DELTOIDEA BURSAGE	5 GALLON	17	2'-0" HT.	
○	CAESALPINIA PULCHERRIMA RED BIRD OF PARADISE	5 GALLON	15	6'-0" HT.	
○	LEUCOPHYLLUM FRUTESCENS 'COMPACTA' COMPACT TEXAS SAGE	5 GALLON	34	5'-0" HT.	
○	LEUCOPHYLLUM FRUTESCENS 'GREEN CLOUD' GREEN CLOUD SAGE	5 GALLON	25	5'-0" HT.	
○	MULLENBERGIA RIGIDA PURPLE MUHLY	5 GALLON	7	2'-0" HT.	
○	RUELLIA BRITTONIANA RUELLIA	5 GALLON	4	2'-0" HT.	
○	RUELLIA BRITTONIANA 'CHI CHI' PINK RUELLIA	5 GALLON	21	3'-0" HT.	
○	RUELLIA PENINSULARIS BLUE RUELLIA	5 GALLON	15	3'-0" HT.	
ACCENTS:					
○	AGAVE 'BLUE FLAME' BLUE FLAME AGAVE	5 GALLON	1	2'-0" HT.	
○	AGAVE NEOMEXICANA NEW MEXICO CENTURY PLANT	5 GALLON	32	3'-0" HT.	
○	PEDILANTHUS MACROCARPUS SLIPPER PLANT	5 GALLON	8	3'-0" HT.	
GROUND COVER:					
○	ACACIA REDOLENS 'DESERT CARPET' TRAILING DESERT ACACIA	5 GALLON	34	2'-0" HT.	
○	LANTANA MONTEVIDENSIS 'NEW GOLD' YELLOW TRAILING LANTANA	5 GALLON	31	2'-0" HT.	
HEADER:					
—	CONCRETE HEADER				
LAWN:					
■	'BOB SOD'	500		2,170 S.F.	
DECOMPOSED GRANITE:					
■	'EXPRESS CARMEL'	1/2" SCREENED			

PRELIMINARY LANDSCAPE PLAN

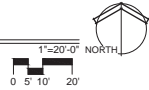

IRRIGATION SYSTEM

ALL PLANT MATERIAL TO BE IRRIGATED BY AN AUTOMATIC UNDERGROUND 'HARD PIPE' DRIP IRRIGATION SYSTEM. TREES, SHRUBS/GROUND COVER, AND LAWN SHALL BE VALVED SEPARATELY. LAWN AREAS TO BE IRRIGATED BY AN UNDERGROUND 'HARD PIPE' SYSTEM WITH LOW ANGLE POP UP SPRAY HEADS.

CPTED NOTE

1. ALL SHRUBS AND GROUND COVER WITHIN 0'-6" OF A SIDEWALK, PARKING SPACE, ENTRY, OR IN THE SIGHT VISIBILITY TRIANGLE SHALL BE 2'-0" MAX HEIGHT AT MATURITY.
2. ALL SHRUBS AND GROUND COVER WITHIN 6'-12" OF A SIDEWALK OR PARKING SPACE SHALL BE 3'-0" MAX HEIGHT AT MATURITY.

DEMOLITION NOTES

1. CONTRACTOR SHALL COORDINATE EXISTING PLANTS TO BE REMOVED AND EXISTING PLANTS TO REMAIN WITH OWNER'S REPRESENTATIVE AND GENERAL CONTRACTOR.
2. COMPLETELY REMOVE TRUNK, ROOTBALL, LIMBS, AND LEAVES OF PLANTS TO BE REMOVED. LEGALLY DISPOSE OF ALL WASTE MATERIAL OFF SITE.
3. REPAIR GRADE AS REQUIRED DUE TO ROOTBALL REMOVAL.

EXISTING PLANT MATERIAL

SYMBOL	BOTANICAL NAME COMMON NAME
TREES:	
○	EXISTING TREE TO BE REMOVED
AE	ACACIA ANEURA MULGA
SA	ACACIA STENOPHYLLA SHOESTRING ACACIA
PV	CERCIDILUM PRAEOX SONORAN PALO VERDE
P	PINUS ELДАРICA MONDELL PINE
M	PROSOPIS SPP. THORNLESS MESQUITE

NOTE:

1. PROTECT EXISTING PLANTS TO REMAIN FROM DAMAGE DURING CONSTRUCTION. REPLACE DAMAGED PLANTS WITH LIKE KIND AND SIZE AT NO ADDITIONAL COST TO OWNER.
2. PROVIDE IRRIGATION TO EXISTING PLANTS TO REMAIN DURING CONSTRUCTION.



ROSS DESIGN GROUP L.L.C.

ARCHITECTURE INTERIORS PLANNING PROJECT MANAGEMENT

414 E. MILL AVENUE, SUITE 207
TEMPE, ARIZONA 85281
PHONE 480.894.9286
FAX 480.894.9301

REVISIONS

△	
△	
△	

THE HUMAN BEAN COFFEE

1602 N. SCOTTSDALE ROAD
TEMPE, AZ 85281

3RD PRELIMINARY SITE PLAN REVIEW

AS MANUFACTURED BY GRANITE EXPRESS MESA, AZ
PH: 480.354.6809
ALL LANDSCAPE AREAS TO RECEIVE A 2" LAYER UNLESS OTHERWISE NOTED ON PLANS



DATE: 10.28.2010 SHEET NO:

SCALE: 1"=20'-0" OF 1

DRAWN BY: [Signature]

CHECKED BY: [Signature]

PRELIMINARY LANDSCAPE PLAN

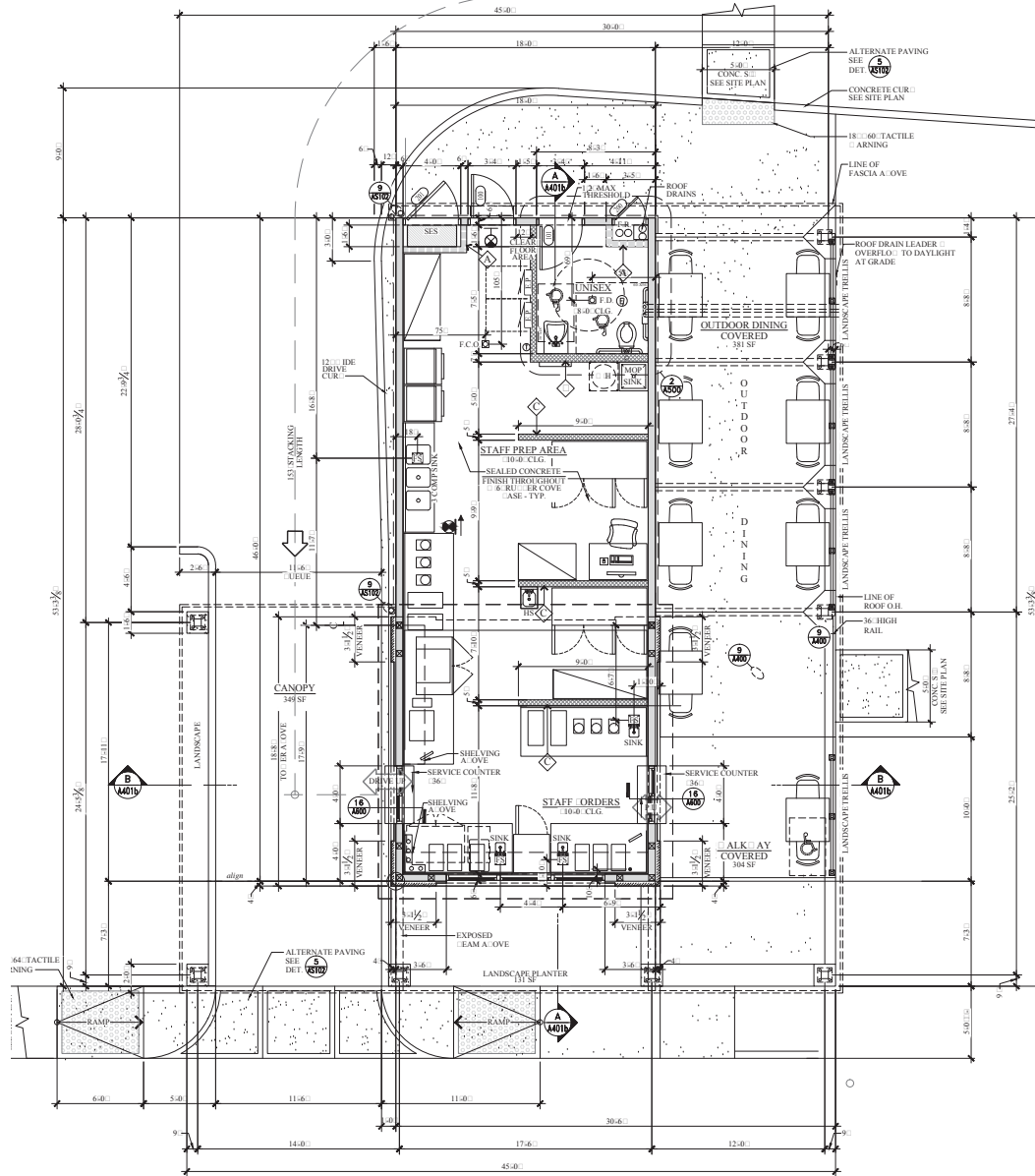

GENERAL NOTES:

1. ALL WORK SHALL BE FURNISHED AND INSTALLED IN COMPLIANCE WITH APPLICABLE BUILDING CODES AND THE HIGHEST PROFESSIONAL STANDARDS OF THE VARIOUS TRADES PERFORMING UNDER THIS CONTRACT.
2. ALL REQUIRED INSPECTIONS TO COMPLY WITH THE LOCAL BUILDING CODE AND APPLICABLE CITY AMENDMENTS.
3. ALL DIMENSIONS SHALL BE FIELD CHECKED, CHECKED IN SHOP AND VERIFIED PRIOR TO THE PERFORMANCE OF ANY WORK, AND THE ARCHITECT SHALL BE NOTIFIED IMMEDIATELY OF ANY DISCREPANCIES IN WRITING. APPROVED RESOLUTION SHALL BE OBTAINED FROM ARCHITECT PRIOR TO PROCEEDING WITH WORK.
4. GENERAL CONTRACTOR SHALL COORDINATE THE WORK OF ALL TRADES AND SHALL BE RESPONSIBLE FOR THE SCHEDULING OF THE WORK. ALL PLUMBING AND ELECTRICAL WORK SHALL BE COMPLETED PRIOR TO THE START OF OTHER TRADES UNLESS OTHERWISE SPECIFIED.
5. ALL CONSTRUCTION SHALL MEET ACCEPTABLE INDUSTRY STANDARDS EVEN IF NOT SPECIFIED IN DETAIL.
6. ESTABLISH AND VERIFY ALL OPENINGS AND INSERTS FOR MECHANICAL, ELECTRICAL, AND PLUMBING (MEPE) WITH APPROPRIATE TRADES, DRAWINGS AND SPECIFICATIONS PRIOR TO CONSTRUCTION.
7. PRIOR TO CONSTRUCTION, THE CONTRACTOR SHALL VERIFY AND BE RESPONSIBLE FOR THE CORRECTNESS OF ALL DIMENSIONS.
8. ANY ENGINEERING DESIGN PROVIDED BY OTHERS AND SUBMITTED FOR REVIEW SHALL BEAR THE SEAL OF AN ENGINEER REGISTERED IN THIS STATE.
9. CONTRACTOR SHALL BE RESPONSIBLE FOR CLARIFICATION OF DOCUMENTS SHOULD THE CONTRACTOR FIND DISCREPANCIES AND/OR AMBIGUOUS DRAWINGS OR DOCUMENTS, OR SHOULD HE BE IN DOUBT AS TO THEIR MEANING, AND SHALL NOTIFY THE ARCHITECT.
10. EXIT DOORS TO BE OPENED FROM INSIDE WITHOUT USE OF A KEY OR ANY SPECIAL KNOWLEDGE OR EFFORT.
11. ALL DOORS TO HAVE HANDICAP ACCESSIBLE HARDWARE OVERHANDLES PER ADA 4.19.
12. MANUALLY OPERATED EDGE OR SURFACE MOUNTED FLUSH DOOR HARDWARE SHALL BE PROHIBITED.
13. ALL INTERSECTIONS ARE 90° UNLESS OTHERWISE NOTED. ALL ANGLES ARE 45°.
14. EXIT SIGNS ARE REQUIRED SEE ELECTRICAL FLOOR PLAN.
15. EMERGENCY LIGHTING IS REQUIRED REFER TO ELECTRICAL DRAWINGS.
16. TYPE 2A-B-C FIRE EXTINGUISHERS SHALL BE LOCATED THROUGHOUT THE PROJECT. SEE ARCHITECTURAL FLOOR PLAN. ALL FINAL FIRE EXTINGUISHER LOCATIONS FINAL COUNTIES AS DETERMINED BY THE MARSHAL.
17. ALL WORK SHALL BE COMPLETED PRIOR TO ARCHITECT APPROVAL AT LEAST 14 DAYS PRIOR TO A RECEPTION OR INSTALLATION.
18. ALL DOORS WITHIN THE ACCESSIBLE PATH TO HAVE A MINIMUM CLEARANCE AT THE STROKE PULL SIDE PER A.D.A.
19. FLOOR FINISHES TO BE DETERMINED BY THE ARCHITECT.
20. ALL FINISHES PAINTED GYP. D. COLOR SELECTION TO BE DETERMINED BY THE ARCHITECT.
21. TO COORDINATE STYLE TYPE OF CASE AT ALL PUBLIC AREAS WITH OWNER AND MECHANICAL CONTRACTOR.
22. SEE SHEET A-01 FOR TOILET ROOM ELEVATIONS. PLUMBING FIXTURE MOUNTING HEIGHTS.
23. EXISTING SIGNS, EMERGENCY LIGHTS, FIRE EXTINGUISHER LOCATIONS ARE SUBJECT TO FINAL APPROVAL OF FIRE MARSHAL. PROVIDE ALL ACCESS FOR ADDITIONAL COMPONENTS. INSTALLATION AND/OR RELOCATION AT END OF PROJECT AT TIME OF FIRE DEPARTMENT SIGN OFF.
24. PROVIDE PROPER MOUNTING METAL STUD JACKING AT ALL MOUNTED FIXTURES AND/OR EQUIPMENT TO COORDINATE WITH ALL SUB CONTRACTORS THE EXACT LOCATION OF MOUNTED METAL JACKING PRIOR TO INSTALLATION OF ALL MOUNTED FIXTURES AND/OR EQUIPMENT.
25. REFER TO MECHANICAL, PLUMBING, AND ELECTRICAL SHEETS FOR ADDITIONAL INFORMATION.
26. GENERAL CONTRACTOR TO FIELD VERIFY ALL STRUCTURAL CONDITIONS AND MEASUREMENTS PRIOR TO A RECEPTION OR ORDERING OF EQUIPMENT.
27. USE ADA COMPLIANT LEVER STYLE DOOR HARDWARE WITH ALL INTERIOR DOORS.
28. ALL KITCHEN EQUIPMENT TO BE SUPPLIED BY OWNER UNLESS OTHERWISE INDICATED ON KITCHEN EQUIPMENT SCHEDULE. SEE SHEET A-02.
29. ALL NECESSARY FINISHES, FIXTURES AND MOUNTING HEIGHTS TO COMPLY WITH ADA RULES AND GUIDELINES.
30. REFER TO RESTROOM SECURITY:
 - 1) PROVIDE SECURITY LIGHTING
 - 2) INSTALL MOUNTED MATHS SENSORS KEY OR REMOTE CONTROL MECHANISM
 - 3) SINGLE USER RESTROOM DOOR HARDWARE TO BE PROVIDED WITH A KEY TO PASS ON THE EXTERIOR SIDE.

CONSTRUCTION FLOOR PLAN LEGEND

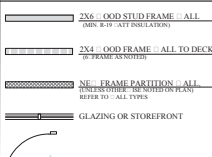

ROSS DESIGN GROUP L.L.C.
ARCHITECTURE INTERIORS PLANNING PROJECT MANAGEMENT
444 NEW YORK CENTER PLAZA
PHOENIX, AZ 85004
PH: (602) 498-1000 FAX: (602) 498-1007
www.rossdesign.com

REVISIONS

THE HUMAN BEAN COFFEE
1602 N. SCOTTSDALE ROAD
TEMPE, AZ 85281

DEVELOPMENT PLAN REVIEW

SEAL OF THE ARCHITECT
JAMES STEPHEN SANDER
NO. 27516
AZ ARCHITECT
11/15/2018

DATE: 11/15/2018 SHEET NO: A200
SCALE: AS SHOWN
DRAWN BY: JSP
PROJECT: HUMAN BEAN COFFEE
FLOOR PLAN - DDS

DEVELOPMENT FLOOR PLAN

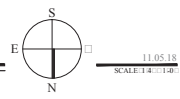

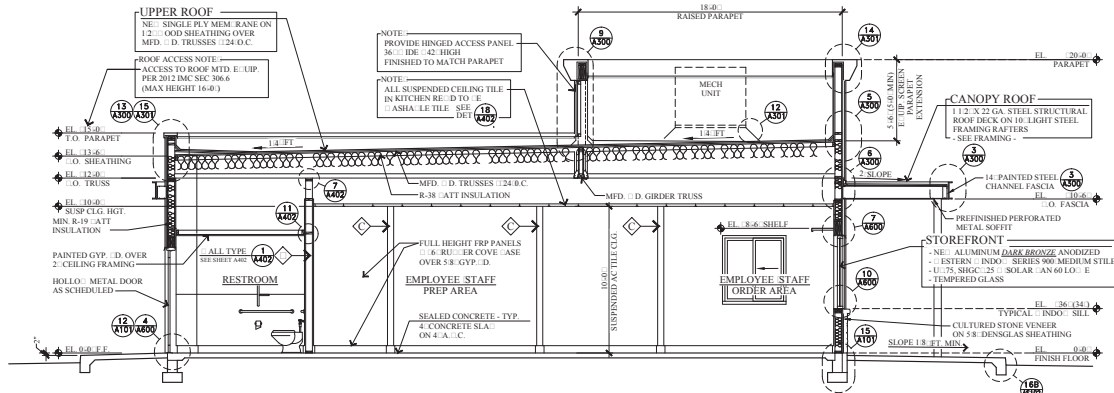

A BUILDING SECTION - VERSION 2 (OOD TRUSS S AP)
 SCALE 1/4" = 1'-0"

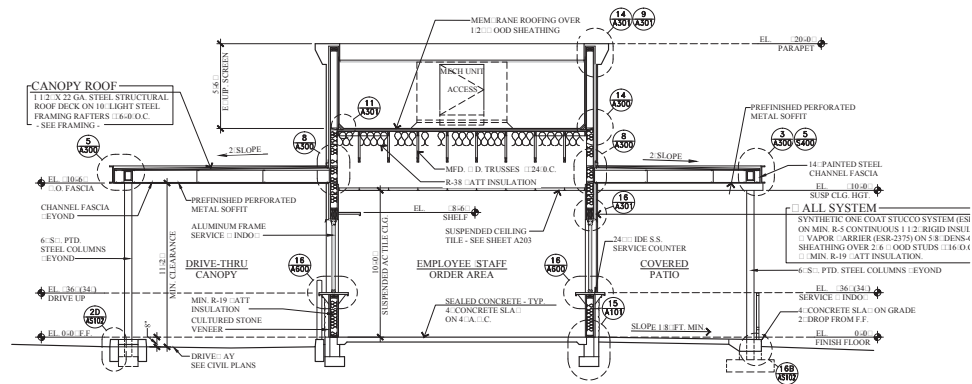

B BUILDING SECTION - VERSION 2 (OOD TRUSS S AP)
 SCALE 1/4" = 1'-0"

MATERIALS & PAINT LEGEND	
○ MAIN BODY COLOR 1	SHER - IN - ILLIAMS (S) - 7521 - DORMER (RO - N)
○ BODY COLOR 2	SHER - IN - ILLIAMS (S) - 6006 - LACK (EAN)
○ BUILDING ACCENT	SHER - IN - ILLIAMS (S) - 7525 - TREE (RANCH)
○ CANOPY TRIM	CUSTOM - ILL METALS - MUSKET SR-30
○ INDO FRAMES	DARK ANODIZED - RONZE
○ STONE ACCENT	EL DORADO - ARM SPRINGS LEDGE PANEL

NOTE: ALL EXTERIOR LIGHTING TO NOT EXCEED 16' AFF.

ROSS DESIGN GROUP L.L.C.
 ARCHITECTURE INTERIORS PLANNING PROJECT MANAGEMENT
 435 N. CRYSTAL CENTER BLVD.
 PHOENIX, AZ 85004
 WWW.ROSSDESIGN.COM

REVISIONS

THE HUMAN BEAN COFFEE
 1602 N. SCOTTSDALE ROAD
 TEMPE, AZ 85281

DEVELOPMENT PLAN REVIEW

DATE: 11.15.2018
 SCALE: AS SHOWN
 DRAWN BY: STAFF
 CHECKED: STAFF

PROJECT: A401b
 SHEET NO.: BUILDING SECTIONS

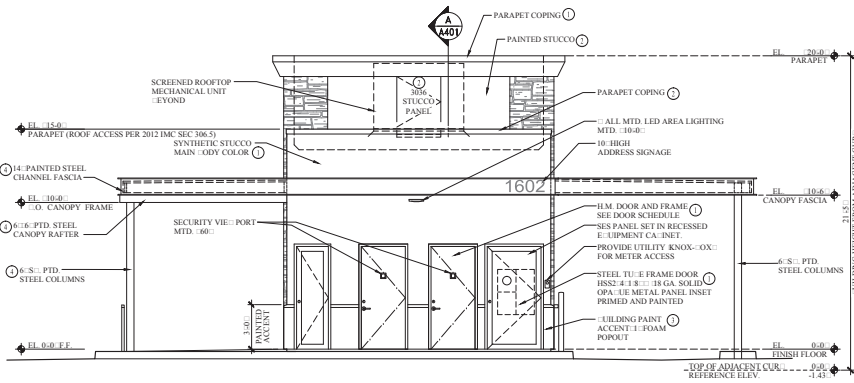

SOUTH ELEVATION

SCALE: 1/4" = 1'-0"

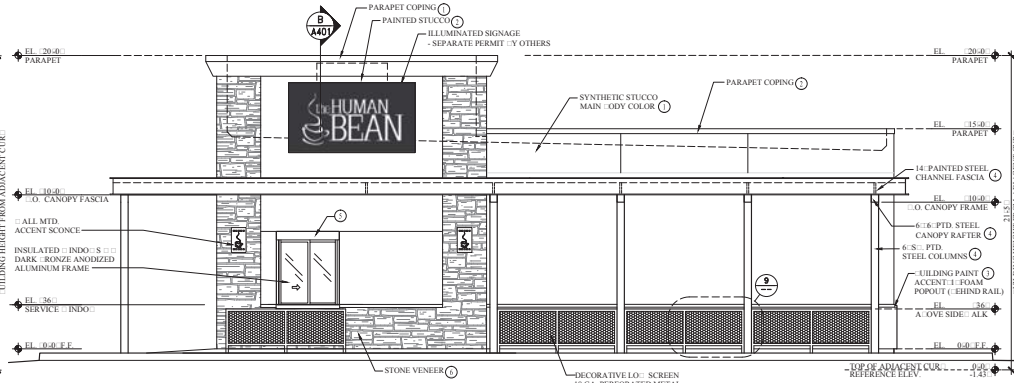

WEST ELEVATION

SCALE: 1/4" = 1'-0"

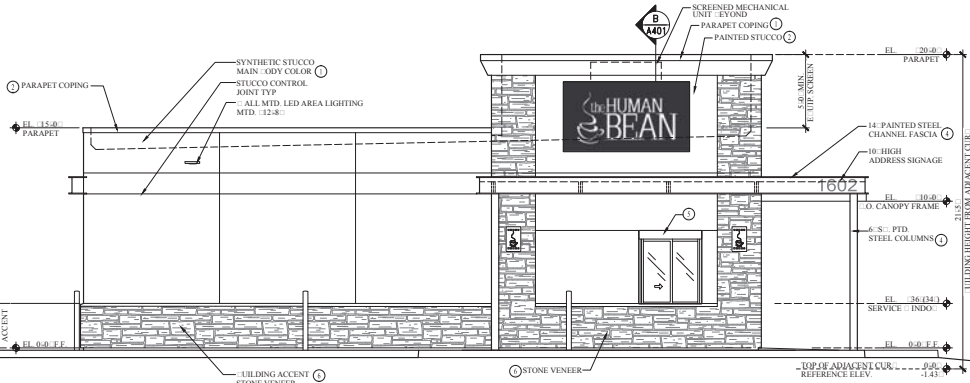

EAST ELEVATION

SCALE: 1/4" = 1'-0"

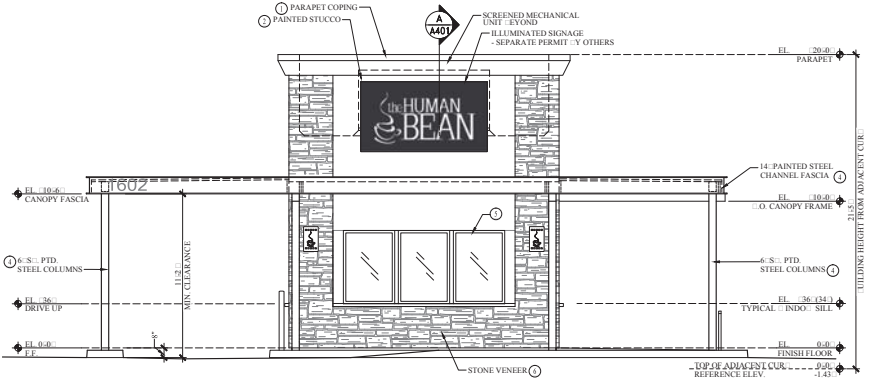

NORTH ELEVATION

SCALE: 1/4" = 1'-0"

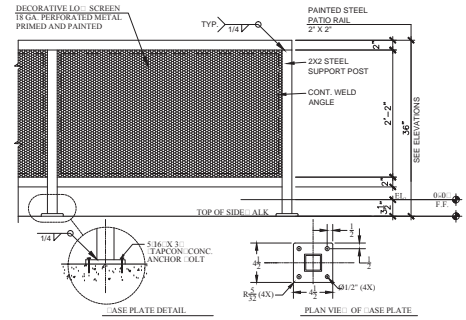

STEEL PATIO RAIL

SCALE: 1" = 1'-0"

MATERIALS & PAINT LEGEND	
1 MAIN BODY COLOR 1	SHERWIN WILLIAMS (S): 7521 - DORMER (RO: N)
2 BODY COLOR 2	SHERWIN WILLIAMS (S): 6006 - LACK (EAN)
3 BUILDING ACCENT	SHERWIN WILLIAMS (S): 7525 - TREE (RANCH)
4 CANOPY TRIM	CUSTOM (L) METALS - MUSKET SR-30
5 INDO. FRAMES	DARK ANODIZED - BRONZE
6 STONE ACCENT	EL DORADO - ARM SPRINGS LEDGE PANEL

- EXTERIOR ELEVATION NOTES**
- REFER TO MECHANICAL, PLUMBING, AND ELECTRICAL SHEETS FOR ADDITIONAL INFORMATION.
 - GENERAL CONTRACTOR TO FIELD VERIFY ALL EXISTING CONDITIONS AND MEASUREMENT PRIOR TO FABRICATION OR ORDERING OF EQUIPMENT.
 - VERIFY FINAL PLACEMENT, SIZES AND EIGHTH OF ROOF MOUNTED AND SUPPORTED MECHANICAL EQUIPMENT AS SPECIFIED ON MECHANICAL PLANS.
 - SEE SHEET GN FOR MATERIAL SPECIFICATIONS.
 - INCORPORATE LIGHTING, ADDRESS SIGNS, AND INCIDENTAL EQUIPMENT ATTACHMENTS (ALARM KLAXONS, SECURITY CAMERAS, ETC.) HERE EXPOSED INTO THE DESIGN OF THE BUILDING ELEVATIONS. EXPOSED CONDUIT, PIPING, OR RELATED MATERIALS IS NOT PERMITTED.
 - ALL EXTERIOR LIGHTING TO NOT EXCEED 160 FOOT CANDLE.
 - UTILITY METERS SHALL UTILIZE A MINIMUM 1" NEMO PER HEIGHT IN ACCORDANCE WITH THE APPLICABLE ELECTRICAL CODE AND UTILITY COMPANY STANDARDS.

ROSS DESIGN GROUP L.L.C.
ARCHITECTURE INTERIORS PLANNING PROJECT MANAGEMENT
435 NEW CENTER BLVD.
PHOENIX, AZ 85004
PH: (480) 942-1000 FAX: (480) 942-1007
www.rossdesign.com

REVISIONS

THE HUMAN BEAN COFFEE
1602 N. SCOTTSDALE ROAD
TEMPE, AZ 85281

DEVELOPMENT PLAN REVIEW

PROFESSIONAL SEAL
7710
JAMES STEPHEN SUBINGER
REGISTERED ARCHITECT
STATE OF ARIZONA

DATE: 11-16-2018
SCALE: AS SHOWN
DRAWN BY: JEFF
CHECKED BY: JEFF
DATE: 11-16-2018

A400

EXTERIOR ELEVATIONS

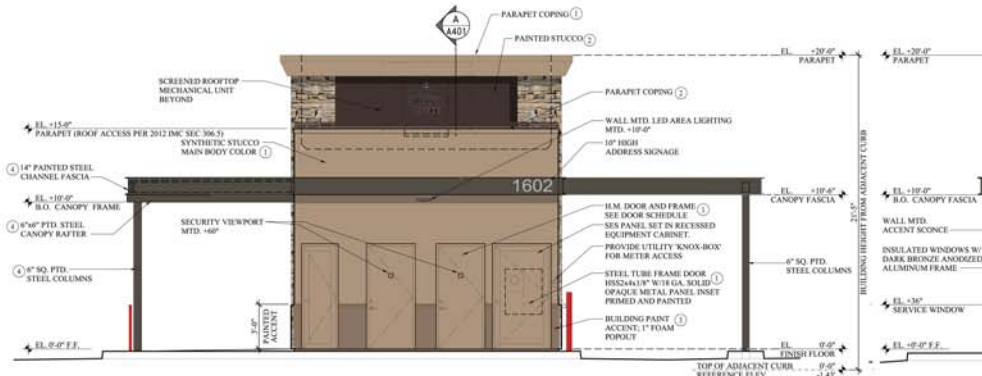

SOUTH ELEVATION



WEST ELEVATION



EAST ELEVATION



NORTH ELEVATION

EXTERIOR ELEVATION - COLORED RENDERINGS

SCALE: 1/4" = 1'-0"

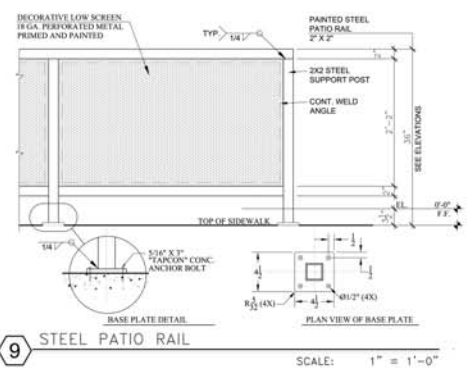

9 STEEL PATIO RAIL
 SCALE: 1" = 1'-0"

MATERIALS & PAINT LEGEND	
① MAIN BODY COLOR 1	SHERWIN WILLIAMS (SW 7521 - DORMER BROWN)
② BODY COLOR 2	SHERWIN WILLIAMS (SW 6006 - BLACK BEAN)
③ BUILDING ACCENT	SHERWIN WILLIAMS (SW 7523 - TREE BRANCH)
④ CANOPY / TRIM	CUSTOM BILT METALS - MUSKET SR-30
⑤ WINDOW FRAMES	DARK ANOZODIZED BRONZE
⑥ STONE ACCENT	EL DORADO - WARM SPRINGS LEDGE PANEL

- EXTERIOR ELEVATION NOTES**
- REFER TO MECHANICAL, PLUMBING, AND ELECTRICAL SHEETS FOR ADDITIONAL INFORMATION.
 - GENERAL CONTRACTOR TO FIELD VERIFY ALL EXISTING CONDITIONS AND MEASUREMENT PRIOR TO FABRICATION OR MEASUREMENT OF EQUIPMENT.
 - VERIFY FINAL PLACEMENT, SIZES AND WEIGHT OF ROOF MOUNTED AND SUPPORTED MECHANICAL EQUIPMENT AS SPECIFIED ON MECHANICAL PLANS.
 - SEE SHEET FOR MATERIAL SPECIFICATIONS.
 - INCORPORATE LIGHTING, ADDRESS SIGNS, AND INCIDENTAL EQUIPMENT ATTACHMENTS (ALARM KEYS, SECURITY CAMERAS, ETC.) WHERE EXPOSED INTO THE DESIGN OF THE BUILDING ELEVATIONS. EXPOSED CONDUIT, PIPING, OR RELATED MATERIALS IS NOT PERMITTED.
 - ALL EXTERIOR LIGHTING TO NOT EXCEED 10'-0" AFF.
 - UTILITY METERS SHALL UTILIZE A MINIMUM 1" NUMBER HEIGHT IN ACCORDANCE WITH THE APPLICABLE ELECTRICAL CODE AND UTILITY COMPANY STANDARDS.

Main Body Color
 Sherwin Williams
 Synthetic Stucco System
 Color: SW 7521 Dormer Brown



Accent Color
 Synthetic Stucco System
 Sherwin Williams
 Color: SW 6006 Black Bean



Wainscot Color
 Synthetic Stucco System
 Sherwin Williams
 Color: SW 7525 Tree Branch



NOTE: See Materials and Paint Legend on Exterior Elevations Sheet

Awning / Flashing
 Custom-Bilt Metals
 Color: Musket SR-30.2

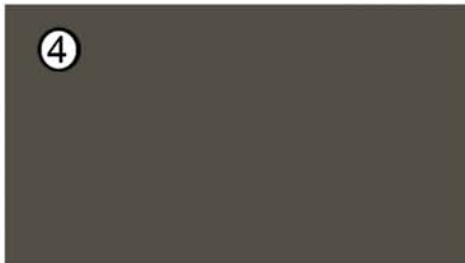

Windows / Framing
 Color: Dark Anodized
 Bronze

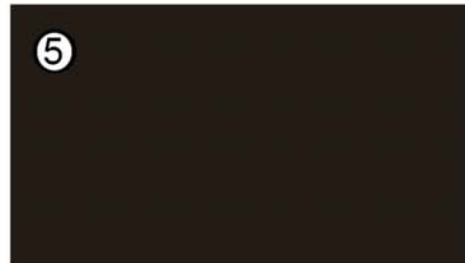

Stone Accent
 El Dorado
 Warm Springs Ledge Panel



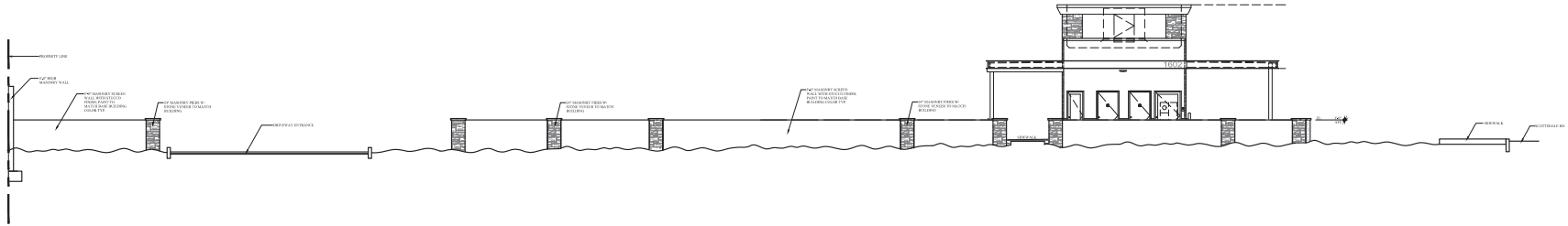

SOUTH STREET ELEVATION

SCALE: 1/8" = 1'-0"

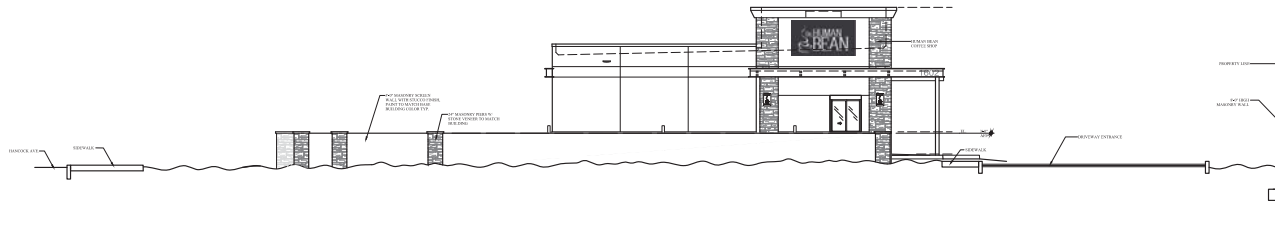

EAST STREET ELEVATION

SCALE: 1/8" = 1'-0"

ROSS DESIGN GROUP L.L.C.
 ARCHITECTURE INTERIORS PLANNING PROJECTMANAGEMENT
 4325 N. GLENVIEW CENTER PLAZA
 PHOENIX, AZ 85018
 TEL: (480) 443-3666 FAX: (480) 426-9907
 www.rossdesignllc.com

REVISIONS

THE HUMAN BEAN COFFEE
 1602 N. SCOTTSDALE ROAD
 TEMPE, AZ 85281

**DEVELOPMENT
 PLAN
 REVIEW**

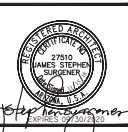

DATE: 11-16-2016 SHEET NO:
 SCALE: AS SHOWN
 DESIGNED BY: STAFF
 CHECKED BY: DAVID BOSS
A402

STREET ELEVATIONS

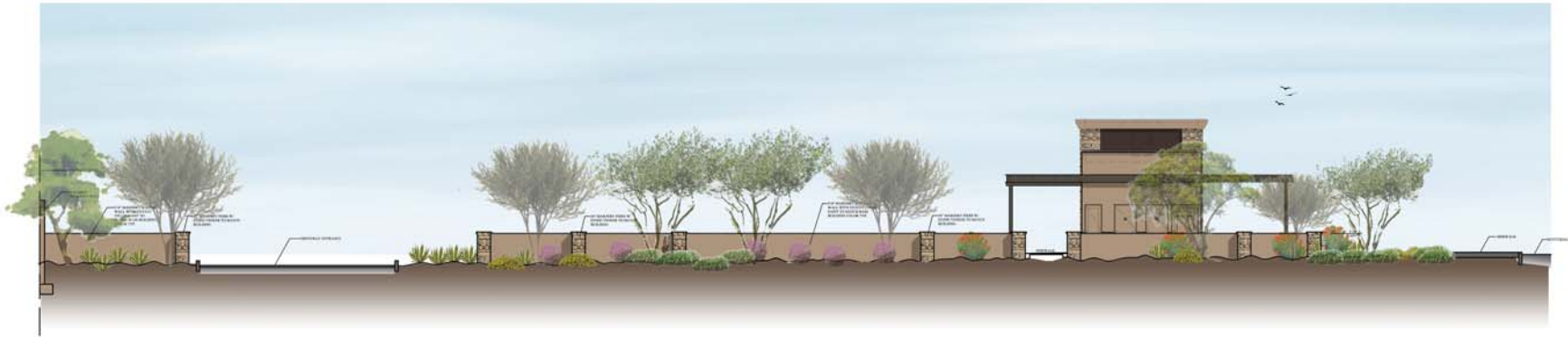

SOUTH STREET ELEVATION

SCALE: 1/8" = 1'-0"



EAST STREET ELEVATION

SCALE: 1/8" = 1'-0"

PLANT LIST	
SYMBOL	BOTANICAL NAME COMMON NAME
TREES:	
	ACACIA ANEURA MULGA
	PARKINSONIA PRAECOX SONORAN PALO VERDE
	PROSOPIS THORNLESS HYBRID 'AZT' AZT THORNLESS MESQUITE
SHRUBS:	
	CAESALPINIA PULCHERRIMA RED BIRD OF PARADISE
	GREEN CLOUD SAGE
ACCENTS:	
	AGAVE NEOMEXICANA NEW MEXICO CENTURY PLANT
GROUND COVER:	
	ACACIA REDOLENS 'DESEERT CARPET' TRAILING DESERT ACACIA
	LANTANA MONTEVIDENSIS 'NEW GOLD' YELLOW TRAILING LANTANA

ROSS DESIGN GROUP L.L.C.
ARCHITECTURE INTERIORS PLANNING PROJECT MANAGEMENT
452 N GAVIN CENTER BLVD
PH: (480) 947-3000 FAX: (480) 947-8187
www.rossdesignllc.com

1
2
3
4
5
6
7
8
9
10
11
12
13
14
15
16
17
18
19
20
21
22
23
24
25
26
27
28
29
30
31
32
33
34
35
36
37
38
39
40
41
42
43
44
45
46
47
48
49
50

THE HUMAN BEAN COFFEE
1602 N. SCOTTSDALE ROAD
TEMPE, AZ 85281

Development
Plan
Review

REGISTERED ARCHITECT
JAMES STEINER
27910
SCOTTSDALE, AZ
JAMES STEINER
ARCHITECTS, P.C.
1602 N. SCOTTSDALE ROAD
TEMPE, AZ 85281

DATE: 11/05/2018 SHEET NO:
SCALE: AS SHOWN
DESIGNED BY: JAMES STEINER
CHECKED BY: JAMES STEINER
DATE: 11/05/2018

STREET ELEVATIONS



