

**CITY OF TEMPE
DEVELOPMENT REVIEW COMMISSION**

**Meeting Date: 2/22/2022
Agenda Item: 5**

ACTION: Request a Use Permit to allow entertainment (karaoke and dancing) for AUGUST KARAOKE BOX, located at 1301 East University Drive, Suite 106. The applicant is Morris Group Architects, LLC.

FISCAL IMPACT: N/A

RECOMMENDATION: Staff – Approve, subject to conditions

BACKGROUND INFORMATION: AUGUST KARAOKE BOX (PL220007) is an existing individual and group karaoke singing business, located in the Aztech Court Commercial Center on the southeast corner of East University Drive and South Dorsey Lane in the PCC-1, Planned Commercial Center Neighborhood District. The Hearing Officer approved the original Use Permit to allow a karaoke club with live entertainment for AUGUST KARAOKE BOX (PL100373) on December 7, 2010. The business is in the process of upgrading its restroom facilities and has installed fixed dancing poles, which are to be used as a prop during karaoke, in at least one (1) of the private rooms. There will be no floor area added to the original leased space. The business plans to continue operating as it has been in the past, hosting small private events such as birthday parties, team-building events, dates, and other similar activities. The request includes the following:

ZUP220005 Use Permit to allow entertainment (karaoke and dancing).

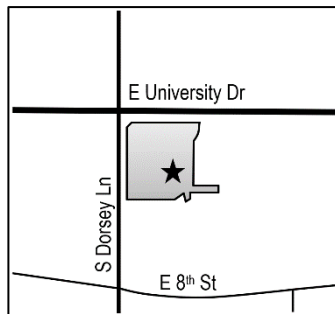

Property Owner	Martin Bloom Investments / Tiburon Investments
Applicant	Bryan Morris, Morris Group Architects, LLC
Zoning District	PCC-1
Site Area	147,783 s.f.
Building Area	40,530 s.f.
Suite Area	1,574 s.f.
Lot Coverage	27% (50% max. allowed)
Building Height	16' (35' max. allowed)
Building Setbacks	75' front, 38' east side, 65' street side, 17' rear (0', 0', 30', 30' min. required)
Vehicle Parking	No change in demand
Bicycle Parking	No change in demand
Hours of Operation	12:00 p.m. to 12:00 a.m., daily
Building Code Occupancy	B

ATTACHMENTS: Development Project File

STAFF CONTACT(S): Lee Jimenez, Senior Planner (480) 350-8486

Department Director: Shelly Seyler, Interim Community Development Director
 Legal review by: N/A
 Prepared by: Lee Jimenez, Senior Planner
 Reviewed by: Steve Abrahamson, Principal Planner

COMMENTS

The site is located between East University Drive, East 8th Street, South McClintock Drive, and South Dorsey Lane. The private rooms vary in size and theme. Each room is equipped with audio and video equipment that offers parties a large catalog collection of songs to perform karaoke with the ability to record themselves. The business also offers props for use by guests which include costume accessories, dancing poles, and other similar items.

PUBLIC INPUT

Staff has received no public comments as of the publishing date of this staff summary report.

POLICE INPUT

A security plan is required for the proposed entertainment use.

USE PERMIT

The proposed use requires a Use Permit to allow entertainment (karaoke and dancing) in the PCC-1 zoning district.

Section 6-308(E) Approval criteria for Use Permit (*in italics*):

1. *Any significant increase in vehicular or pedestrian traffic*; the proposed entertainment use is not expected to significantly increase vehicular or pedestrian traffic more than the existing use and other uses permitted by right in the PCC-1 zoning district.
2. *Nuisance arising from the emission of odor, dust, gas, noise, vibration, smoke, heat or glare at a level exceeding that of ambient conditions*; the proposed entertainment use will take place indoors only and is not expected to generate emissions at a level greater than local ambient conditions.
3. *Contribution to the deterioration of the neighborhood or to the downgrading of property values, which is in conflict with the goals, objectives or policies for rehabilitation, redevelopment or conservation as set forth in the city's adopted plans or General Plan*; the proposed entertainment use does not conflict with any of the City's adopted plans or general plan and is expected to positively contribute to the surrounding area.
4. *Compatibility with existing surrounding structures and uses*; the proposed use does not require alterations to the exterior of the building. Furthermore, the commercial center already includes other entertainment uses such as a billiards hall and a rage release room.
5. *Adequate control of disruptive behavior both inside and outside the premises which may create a nuisance to the surrounding area or general public*; the proposed entertainment use requires a security plan through the City of Tempe Police Crime Prevention Unit which will help the operator plan for potential disruptive behavior that may result from the proposed use.

REASONS FOR APPROVAL:

Based on the information provided by the applicant, the public input received, and the above analysis staff supports approval of the requested Use Permit. This request meets the required criteria and will conform to the conditions.

SHOULD AN AFFIRMATIVE ACTION BE TAKEN ON THIS REQUEST, THE FOLLOWING NUMBERED CONDITIONS OF APPROVAL SHALL APPLY, BUT MAY BE AMENDED BY THE DECISION-MAKING BODY.

CONDITION(S) OF APPROVAL: (Non-standard conditions are identified in bold)

EACH NUMBERED ITEM IS A CONDITION OF APPROVAL. THE DECISION-MAKING BODY MAY MODIFY, DELETE OR ADD TO THESE CONDITIONS.

1. The Use Permit is valid only after a Building Permit has been obtained, the required inspections have been completed, and a Final Inspection has been passed.
2. The Use Permit is valid for the plans as submitted within this application. Any additions or modifications may be submitted for review during the building plan check process.
3. The entertainment use shall only be allowed indoors. No entertainment use shall be allowed outdoors.

4. The entertainment use shall begin no earlier than seven o'clock in the morning (7:00 a.m.) and cease no later than midnight (12:00 a.m.), daily.
5. The applicant shall contact the City of Tempe Crime Prevention Unit for a security plan within 30 days of this approval. Contact 480-858-6409 before March 24, 2022.
6. **Outside paid-for entertainment services (i.e., bands or dancers) shall be prohibited.**

CODE/ORDINANCE REQUIREMENTS:

THE BULLETED ITEMS REFER TO EXISTING CODE OR ORDINANCES THAT PLANNING STAFF OBSERVES ARE PERTINENT TO THIS CASE. THE BULLET ITEMS ARE INCLUDED TO ALERT THE DESIGN TEAM AND ASSIST IN OBTAINING A BUILDING PERMIT AND ARE NOT AN EXHAUSTIVE LIST.

USE PERMIT:

- The Use Permit is valid for AUGUST KARAOKE BOX and may be transferable to successors in interest through an administrative review with the Community Development Director, or designee.
- The Use Permit approval shall be void if the use is not commenced or if an application for a building permit has not been submitted, whichever is applicable, within twelve (12) months after the use permit is granted or within the time stipulated by the decision-making body.
- The decision-making body, upon finding that the applicant has not taken corrective actions to resolve issues related to the permit/approval and that a continuation of the permit/approval is not in the interest of the public health, safety and general welfare, can revoke the permit/approval after providing written notice of its intentions to the holder of the permit.
- Specific requirements of the **Zoning and Development Code (ZDC)** are not listed as a condition of approval but will apply to any application. To avoid unnecessary review time and reduce the potential for multiple plan check submittals, become familiar with the ZDC. Access the ZDC through <http://www.tempe.gov/zoning> or purchase from Development Services.
- All business signs shall receive a Sign Permit. Contact sign staff at 480-350-8435.
- Any intensification or expansion of use shall require a new Use Permit.
- All required permits and clearances shall be obtained from the Audit and Licensing Division of the City of Tempe prior to the Use Permit becoming effective.
- All required Federal, State, County, and Municipal permits, licenses, and clearances shall be obtained, or the Use Permit is void.
- Music, sound, or entertainment shall not violate the City of Tempe Noise Ordinance.

HISTORY & FACTS:

July 20, 1987	Building Safety Department final inspection passed for the construction of Aztech Court, located at 1301 East University Drive in the I-2, General Industrial District.
March 25, 1987	Board of Adjustment approved use permit to operate a commercial business in an industrial district for BEAUVAIS FITNESS CENTER, located at 1301 East University Drive in the I-2, General Industrial district. (A-87-3.11)
May 17, 1988	Hearing Officer approved a Variance to reduce the required parking from 235 to 210 at 1301 E University Drive in the PCC-1, Planned Commercial Center Neighborhood District.
August 9, 2005	Planning & Zoning Commission approved the request by A Plus Beauty School for a Use Permit to allow a beauty/vocational school, located at 1301 East University Drive, Suite 118 & 119 in the PCC-1, Planned Commercial Center Neighborhood District. (CC050046 / #SIP-2005.67)
May 21, 2014	Hearing Officer approved use permit to allow the resale of items at a second hand store for DAVI'

TREASURES, located at 1301 East University Drive in the PCC-1, Planned Commercial Center Neighborhood District. (PL140112)

- April 28, 2016 Community Development Department Planning Division staff approved shared parking analysis for GLASS BOARD GAME CAFÉ, located at 1301 East University Drive, Suite 130 in the PCC-1, Planned Commercial Center Neighborhood District.
- December 7, 2010 Hearing Officer approved Use Permit to allow an amusement use (karaoke club) with live entertainment for AUGUST KARAOKE BOX, located at 1301 East University Drive, Suite 106 in the PCC-1, Planned Commercial Center Neighborhood District. (PL100373)
- January 9, 2006 Development Services Department Board of Adjustment staff approved request for Use Permit transfer for T'S LIQUOR AND CONVENIENCE STORE, located at 1301 East University Drive, Suite 132 in the PCC-1, Planned Commercial Center Neighborhood District. (BA050201)
- May 17, 2017 Hearing Officer approved a Use Permit to allow an animal kennel (cats) for LA GATTARA CAT CAFÉ, located at 1301 East University Drive, Suite 136 in the PCC-1, Planned Commercial Center Neighborhood District. (PL170083)
- August 15, 2017 Hearing Officer approved a Use Permit to allow an amusement business (stress relief room) for SIMPLY SMASHING, located at 1301 East University Drive, Suite 101 in the PCC-1, Planned Commercial Center Neighborhood District. (PL170224)

ZONING AND DEVELOPMENT CODE REFERENCE:

[Section 3-202, Permitted Uses in Commercial and Mixed-Use Districts](#)

[Section 6-308, Use Permit](#)

[Section 6-313, Security Plan](#)

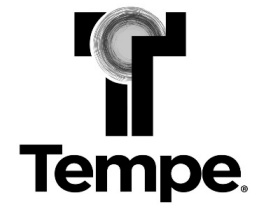

DEVELOPMENT PROJECT FILE

for

AUGUST KARAOKE BOX

(PL220007)

ATTACHMENTS:

1. Location Map
2. Aerial
- 3-4. Letter of Explanation
5. Site Plan
6. Floor Plan
- 7-26. Site Context Photos



AUGUST KARAOKE BOX

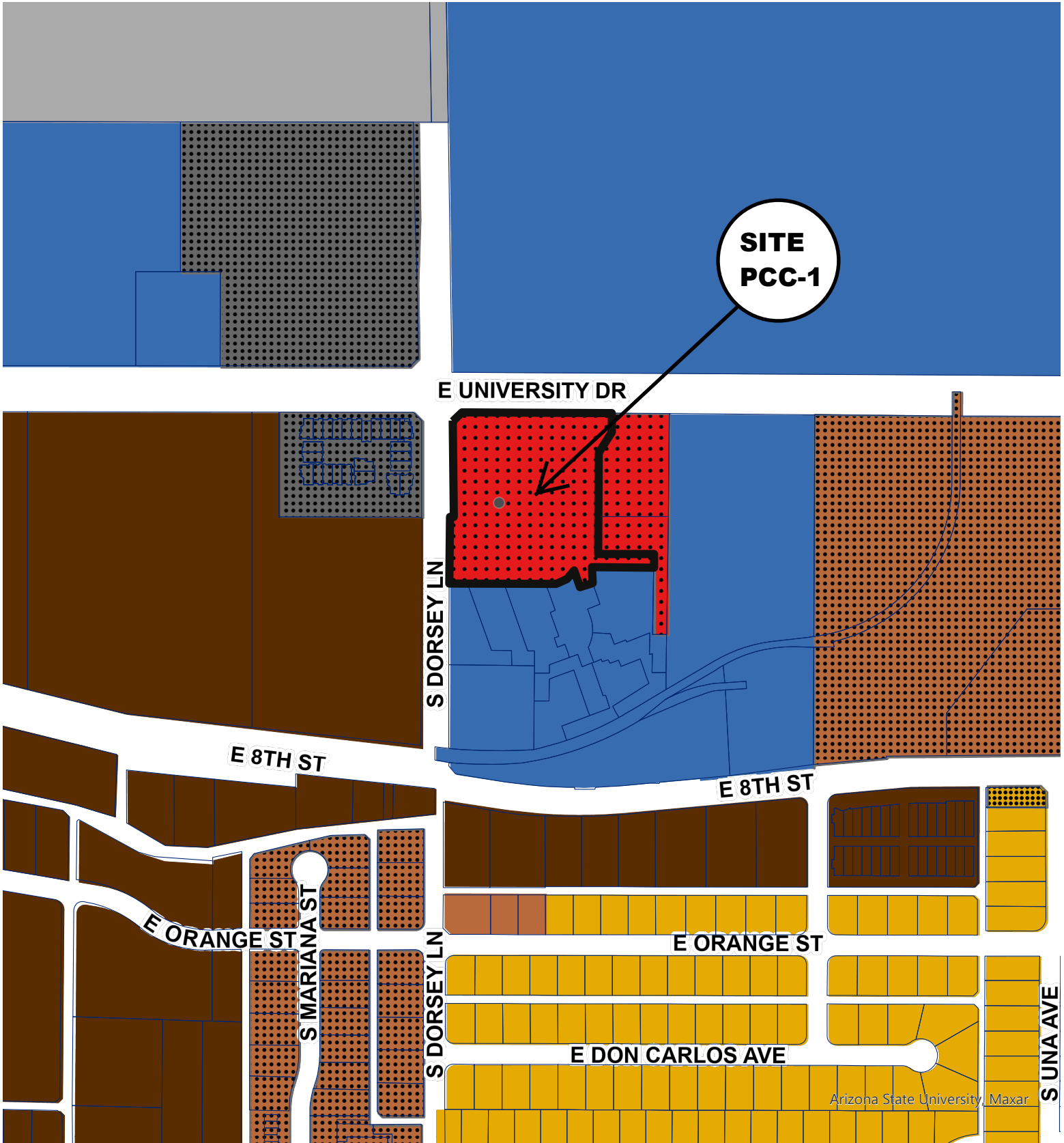

- General Industrial District (GID)
- Mixed Use High (MU-4)
- Mixed Use Educational (MU-ED)
- Planned Commercial Center Neighborhood (PCC-1)
- Single-Family Residential (R1-6)
- Single-Family Residential Planned Area Dev (R1-PAD)
- Multi-Family Residential (R-2)
- Multi-Family Residential Limited (R-3)
- Multi-Family Residential General (R-4)

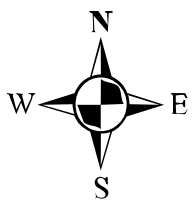



Tempe

PL220007

AUGUST KARAOKE BOX

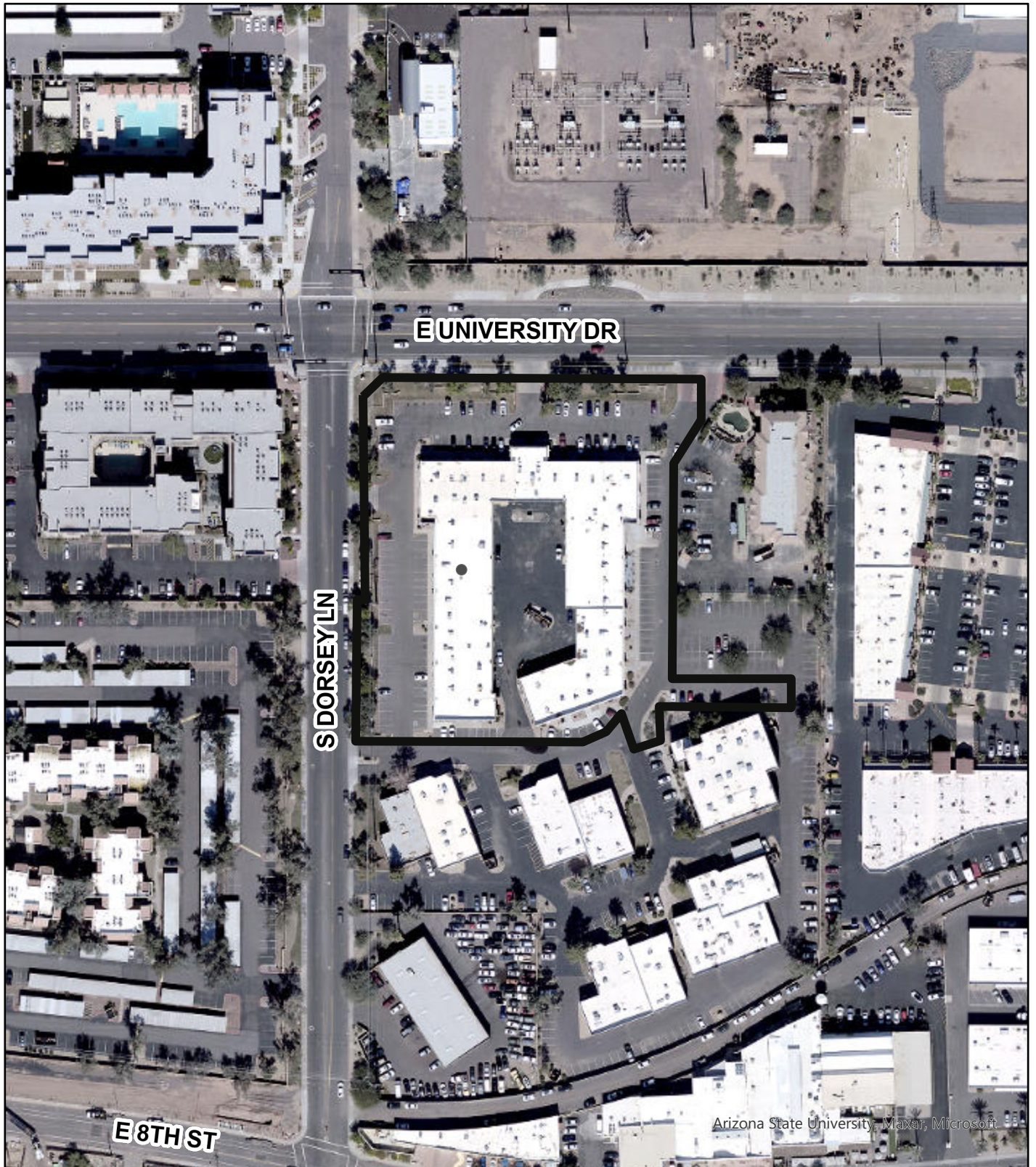

Aerial Map

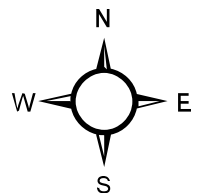



ARCHITECTURE
CONSTRUCTION
DEVELOPMENT

January 10, 2022

To: City of Tempe
Community Development Department
Planning Division

RE: Use Permit Application for:
August Karaoke Box
1301 E. University Drive, Suite 106
Tempe, Arizona 85281

To Whom it may concern,

Please accept his application for a use permit for the purpose of allowing music to be played as a part of the business purpose of this venue.

August Karaoke Box is an existing tenant within a larger commercial retail center. This retail center includes other similar business activities including a neighborhood bar (with music), dining establishments, an athletic gym and a "rage release room" (an amusement business that allows smashing items in a controlled environment).

The nature of this business is individual and group karaoke singing (entertainment), in a private environment. Individuals and small groups of people can reserve one of several rooms for their own private entertainment. It is designed for birthday parties, business team building, dates, and similar activities.

The private rooms vary in size and have different themes. The rooms come equipped with state-of-the-art audio and video equipment so parties can select from a large catalog of songs to perform karaoke and video themselves for posterity. In addition to the audio-video equipment, there are also props for use by guests to enhance their experience. These include costume accessories, dancing poles, and other similar items.

There will be no paid-for outside entertainment allowed. In other words, there will be no music bands or dancers provided for entertainment purposes - this is strictly a venue for private parties to create their own entertainment. As such, part of this use permit request is to allow the use of the fixed dancing poles as they are a prop used as part of the karaoke experience.

This venue will provide non-alcoholic beverages and pre-packaged snacks for sale. There will be two or three employees on premise during business hours to accept reservations and provide guidance and support for guests. Business hours are 12pm to 12am, 7 days a week and reservations are required.

937 W. Sherri Drive Gilbert, Arizona 85233 p. 480.235.7260
email: bryanmorris00@gmail.com



This business is very similar to the existing "Simply Smashing Rage Room", suite 101, in the same building that provides private entertainment and props for use by guests who create their entertainment.

There should be no impacts to neighboring business or properties as the entertainment is kept within the business suite and cannot be heard outside of the business. This business is compliant with the zoning district and overall building use. There will be no impacts to existing vehicular and pedestrian traffic and there is no change to the existing building or site.

In addition to this use permit application, we will be submitting plans (under separate submittal) for the purpose of obtaining a building permit and bringing the existing restrooms into compliance with accessibility standards

If you have any questions, please do not hesitate to call me at the number below.

Sincerely,

Bryan Morris, AIA
MORRIS GROUP ARCHITECTS, LLC
(480) 235-7260
email: bryanmorris00@gmail.com

2416 BORDER SHEET

D

C

B

A

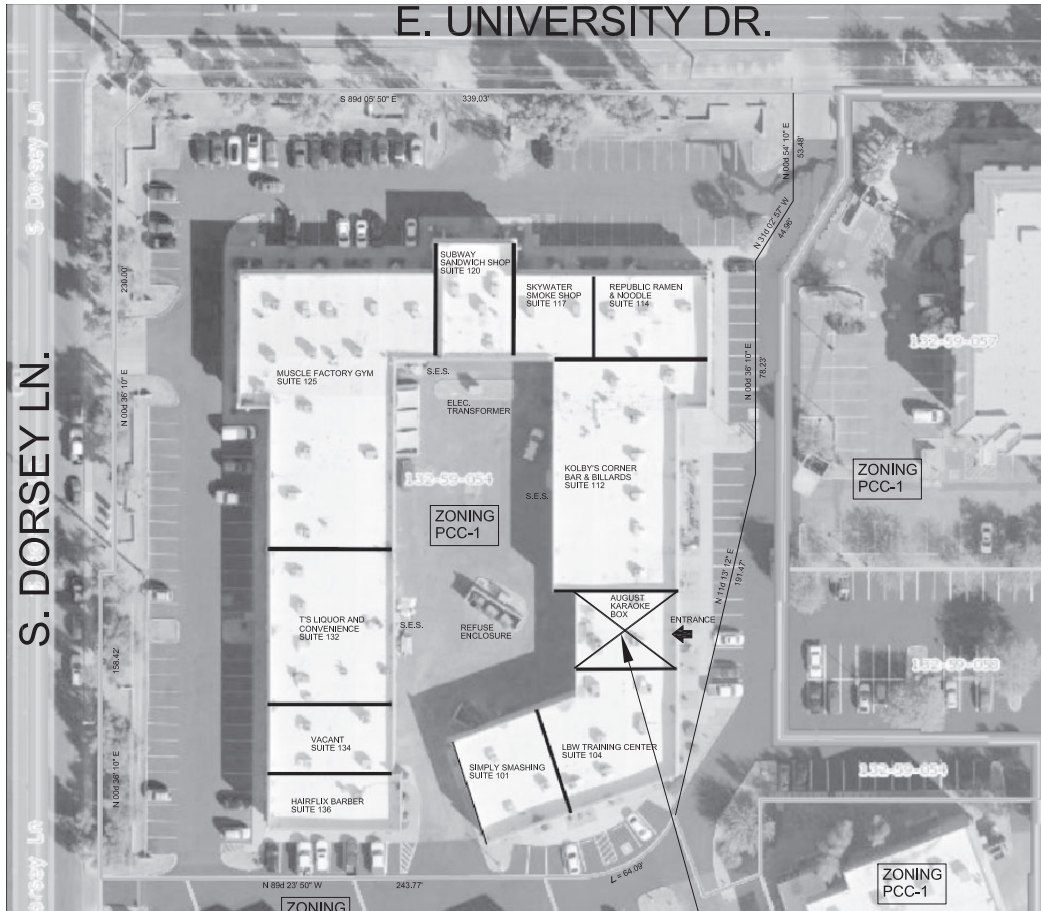

SITE PLAN

SCALE: 1" = 30'-0"

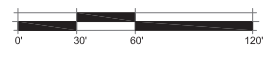

THIS PROJECT: AUGUST KARAOKE BOX
1301 E. UNIVERSITY DRIVE, SUITE 106
TEMPE, AZ 85281
'B' OCCUPANCY
1,574 S.F. (NO CHANGE TO OVERALL TENANT SPACE,
HOWEVER, RESTROOMS WILL BE REQUIRED TO
COMPLY WITH ACCESSIBILITY STANDARDS (UNDER
SEPARATE SUBMITTAL))

PROJECT DATA

PROJECT NAME: AUGUST KARAOKE BOX
PROJECT TYPE: PRIVATE KARAOKE ENTERTAINMENT VENUE
PROJECT ADDRESS: 1301 E. UNIVERSITY DRIVE, SUITE 106, TEMPE, ARIZONA 85281
TYPE OF CONSTRUCTION: TYPE V-B (EXISTING)
PROJECTED LAND USE: COMMERCIAL
PROJECTED DENSITY: MEDIUM TO HIGH DENSITY (UP TO 25 du/ac)
ZONING: PCC-1
TOTAL SITE AREA: 147,783 S.F.
TOTAL BLDG AREA: 40,530 S.F.
TOTAL LOT COVERAGE: 27%
TENANT AREA: 1,574 S.F.
OCCUPANCY TYPE: B
CONSTRUCTION TYPE: V-B
BUILDING HEIGHT: 1-STORY (APPROX. 16'-0")
EXISTING PARKING: 180 SPACES
OCCUPANT LOAD (THIS TENANT: BREAKDOWN): 75 OCCUPANTS (SEE SHEET A.1 FOR BREAKDOWN)
SPRINKLERED: EXISTING

LETTER OF EXPLANATION

THIS APPLICATION FOR A USE PERMIT IS FOR THE PURPOSE OF ALLOWING MUSIC TO BE PLAYED AS A PART OF THE BUSINESS PURPOSE OF THIS VENUE.
AUGUST KARAOKE BOX IS AN EXISTING TENANT WITHIN A LARGER COMMERCIAL RETAIL CENTER. THIS RETAIL CENTER INCLUDES OTHER SIMILAR BUSINESS ACTIVITIES INCLUDING A NEIGHBORHOOD BAR (WITH MUSIC), DINING ESTABLISHMENTS, AN ATHLETIC GYM AND A "RAGE RELEASE ROOM" (AN AMUSEMENT BUSINESS THAT ALLOWS SMASHING ITEMS IN A CONTROLLED ENVIRONMENT).
THE NATURE OF THIS BUSINESS IS INDIVIDUAL AND GROUP KARAOKE SINGING (ENTERTAINMENT), IN A PRIVATE ENVIRONMENT. INDIVIDUALS AND SMALL GROUPS OF PEOPLE CAN RESERVE ONE OF SEVERAL ROOMS FOR THEIR OWN PRIVATE ENTERTAINMENT. IT IS DESIGNED FOR BIRTHDAY PARTIES, TEAM-BUILDING, DATES, AND SIMILAR ACTIVITIES.
THE PRIVATE ROOMS VARY IN SIZE AND HAVE DIFFERENT THEMES. THE ROOMS COME EQUIPPED WITH STATE-OF-THE-ART AUDIO AND VIDEO EQUIPMENT SO PARTIES CAN SELECT FROM A LARGE CATALOG OF SONGS TO PERFORM KARAOKE AND VIDEO THEMSELVES FOR POSTERITY. IN ADDITION TO THE AUDIO-VIDEO EQUIPMENT, THERE ARE ALSO PROPS FOR USE BY GUESTS TO ENHANCE THEIR EXPERIENCE. THESE INCLUDE COSTUME ACCESSORIES, DANCING POLES, AND OTHER LIKE ITEMS.
THERE WILL BE NO PAID-FOR OUTSIDE ENTERTAINMENT ALLOWED. IN OTHER WORDS, THERE WILL BE NO MUSIC BANDS OR DANCERS PROVIDED FOR ENTERTAINMENT PURPOSES - THIS IS STRICTLY A VENUE FOR PRIVATE PARTIES TO CREATE THEIR OWN ENTERTAINMENT. AS SUCH, PART OF THIS USE PERMIT REQUEST IS TO ALLOW THE USE OF THE FIXED DANCING POLES AS THEY ARE A PROP USED AS PART OF THE KARAOKE EXPERIENCE.

TENANT LIST

* ALL TENANTS ARE LOCATED AT 1301 E. UNIVERSITY DRIVE

BUSINESS NAME	SUITE	CITY	STATE	ZIP
SIMPLY SMASHING	101	TEMPE	AZ	85281
LBW TRAINING CENTER	104	TEMPE	AZ	85281
AUGUST KARAOKE BOX	106	TEMPE	AZ	85281
KOLBY'S CORNER BAR & BILLARDS	112	TEMPE	AZ	85281
REPUBLIC RAMEN & NOODLE	114	TEMPE	AZ	85281
SKYWATER SMOKE SHOP	117	TEMPE	AZ	85281
SUBWAY SANDWICH SHOP	120	TEMPE	AZ	85281
MUSCLE FACTORY GYM	125	TEMPE	AZ	85281
TS LIQUOR AND CONVENIENCE	132	TEMPE	AZ	85281
VACANT	134	TEMPE	AZ	85281
HAIRFLIX BARBER	136	TEMPE	AZ	85281

PROJECT DIRECTORY

OWNER
AUGUST KARAOKE BOX
CONTACT: SETH WONG
1301 E. UNIVERSITY DRIVE, SUITE 106
TEMPE, ARIZONA 85281
PHONE: (323) 370-5550

ARCHITECT
BRYAN MORRIS, AIA
937 W. SHERRI DRIVE
GILBERT, ARIZONA 85233
PHONE: (480) 235-7260

APPLICABLE CODES

- 2018 INTERNATIONAL BUILDING CODE
- 2018 INTERNATIONAL MECHANICAL CODE
- 2018 INTERNATIONAL PLUMBING CODE
- 2018 INTERNATIONAL FIRE CODE
- 2017 NATIONAL ELECTRIC CODE
- 2006 INTERNATIONAL FUEL GAS CODE
- 2018 INTERNATIONAL EXITING BLDG CODE
- 2018 IECC
- 2010 ADA STANDARDS FOR ACCESSIBLE DESIGN

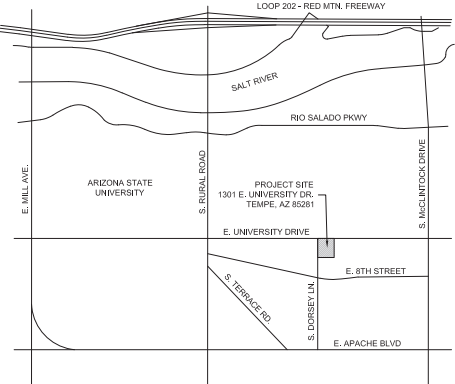

VICINITY MAP

SCALE: NO SCALE



REV. NO.	REV. DESCRIPTION	REV. DATE
1	ISSUE FOR USE PERMIT APPLICATION	01/10/2022

DRAWN BY: BDM
CHECKED BY: BDM
PROJECT NO.: 21009
INITIAL ISSUE DATE: 01/10/2022
FILE NAME:
SCALE: AS NOTED

SHEET NO.



EXPIRES 06/01/2022

C.0



MORRIS GROUP ARCHITECTS, LLC
937 W. Sherril Drive
Gilbert, Arizona 85233
(480) 235-7260
(e) bryanmorris00@gmail.com

**AUGUST KARAOKE BOX
USE PERMIT APPLICATION**
1301 E. UNIVERSITY DRIVE, SUITE 106
TEMPE, ARIZONA 85281

**COVER SHEET
PROJECT INFORMATION**
01/10/2022

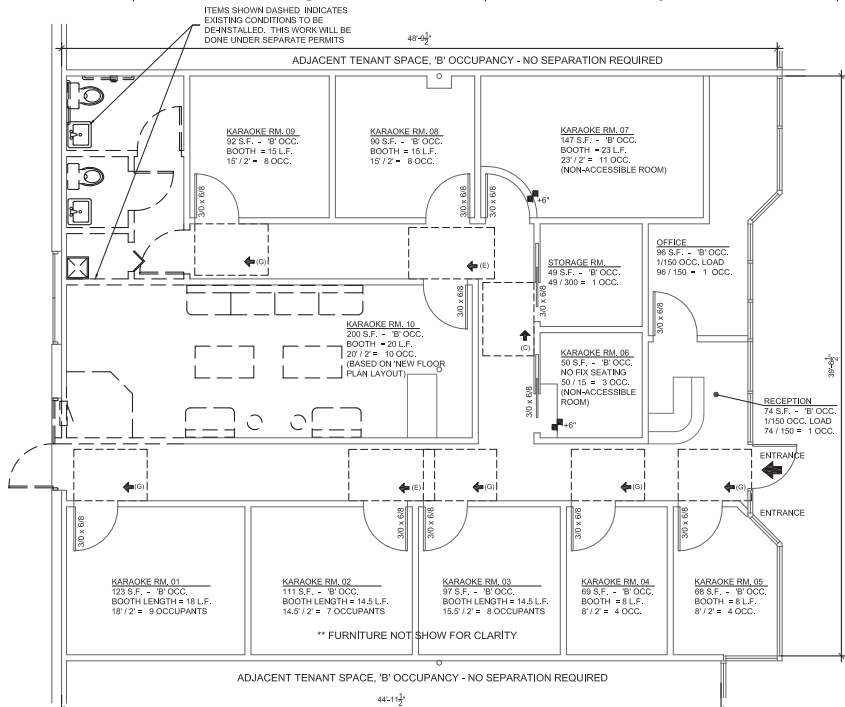

A EXISTING / DEMO FLOOR PLAN
SCALE: 1/4" = 1'-0"
NORTH

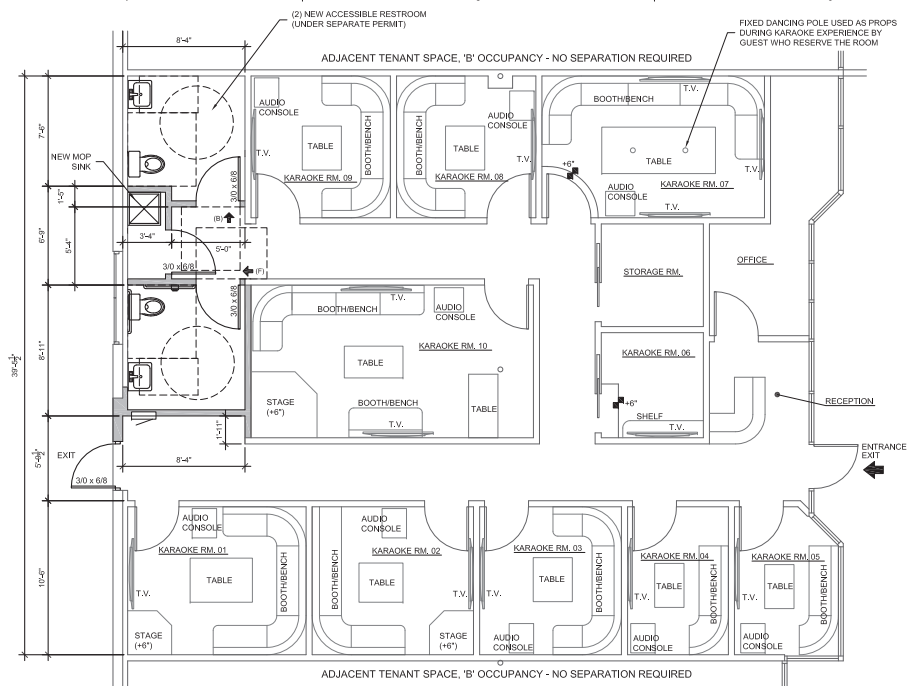

B NEW FLOOR PLAN
SCALE: 1/4" = 1'-0"
NORTH

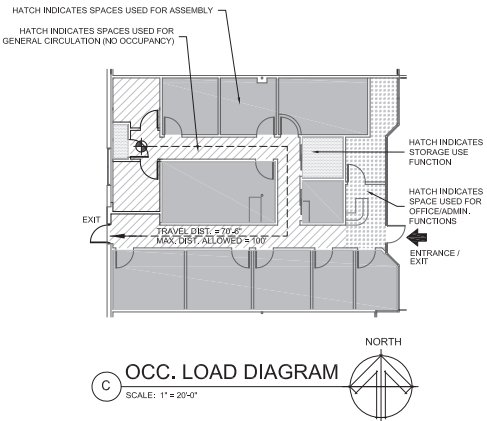

ROOM	S.F.	OCC. TOTAL
KARAOKE RM. 01	123 S.F.	9 OCC.
KARAOKE RM. 02	111 S.F.	7 OCC.
KARAOKE RM. 03	97 S.F.	8 OCC.
KARAOKE RM. 04	69 S.F.	4 OCC.
KARAOKE RM. 05	68 S.F.	4 OCC.
KARAOKE RM. 06	50 S.F.	3 OCC.
KARAOKE RM. 07	147 S.F.	11 OCC.
KARAOKE RM. 08	90 S.F.	8 OCC.
KARAOKE RM. 09	92 S.F.	8 OCC.
KARAOKE RM. 10	S.F.	10 OCC.
RECEPTION	S.F.	1 OCC.
OFFICE	S.F.	1 OCC.
STORAGE	49 S.F.	1 OCC.
TOTAL OCCUPANTS:		75 OCC.

PLUMBING FIXTURES REQUIRED [TABLE 2902.1]

ASSUMES 38 MALE AND 38 FEMALE FOR THE PURPOSE OF DETERMINING PLUMBING FIXTURES BASED ON ASSEMBLY; NIGHTCLUB, BAR...OR SIMILAR PURPOSE*

WATER CLOSET REQ'D: 1 PER 40, EA. WOMEN AND MEN LAVATORIES REQ'D: 1 PER 75 TOTAL

(1) WATER CLOSET AND (1) SINK REQUIRED AND PROVIDED FOR THIS PROJECT

GENERAL NOTES

- OCCUPANT LOAD FOR PRIVATE KARAOKE ROOMS ARE BASED ON "ASSEMBLY WITH FIXED SEATING" PER TABLE 1004.5. 1 PERSON PER 24" OF BOOTH SEATING.
 - 2016 IBC [303.1.2] SMALL ASSEMBLY SPACES: A BUILDING OR TENANT SPACE USED FOR ASSEMBLY PURPOSES WITH AN OCCUPANT LOAD OF LESS THAN 50 PERSONS SHALL BE CLASSIFIED AS A 'B' OCCUPANCY.
 - A ROOM OR SPACE USED FOR ASSEMBLY PURPOSES THAT IS LESS THAN 750 S.F. AND ACCESSORY TO ANOTHER OCCUPANCY SHALL BE CLASSIFIED AS A 'B' OCCUPANCY.
- (2) EXITS REQUIRED BASED ON AN OCCUPANT LOAD GREATER THAN 49 FOR A 'B' OCCUPANCY. (2) EXITS ARE PROVIDED. REAR EXIT DOOR WILL BE MODIFIED UNDER SEPARATE PERMIT SUBMITAL

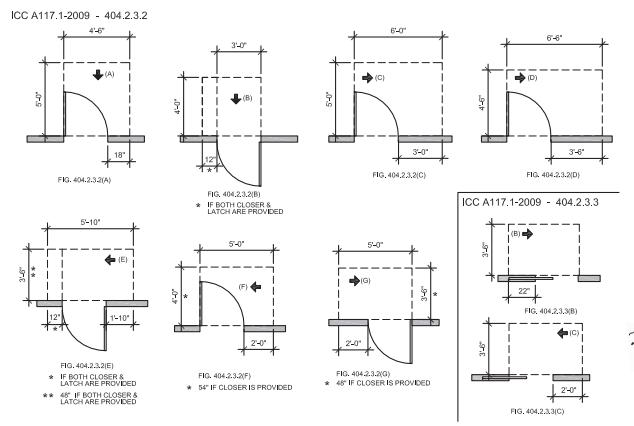

MORRIS GROUP ARCHITECTS, LLC
937 W. Sheri Drive
Gilbert, Arizona 85233
(480) 235-7230
(e) bryanmorris00@gmail.com

**AUGUST KARAOKE BOX
USE PERMIT APPLICATION**
1301 E. UNIVERSITY DRIVE, SUITE 106
TEMPE, ARIZONA 85281

**DEMITION FLOOR PLAN
NEW FLOOR PLAN**
01/10/2022

REV. NO.	REV. DESCRIPTION	REV. DATE
1	ISSUE FOR USE PERMIT APPLICATION	01/10/2022

DRAWN BY: BDM
CHECKED BY: BDM
PROJECT NO.: 21009
INITIAL ISSUE DATE: 01/10/2022
FILE NAME:
SCALE: AS NOTED

BDM SHEET NO.

A.I

RE: Use Permit Application for:
August Karaoke Box
1301 E. University Drive, Suite 106
Tempe, Arizona 85281

SITE CONTEXT PHOTO MAP

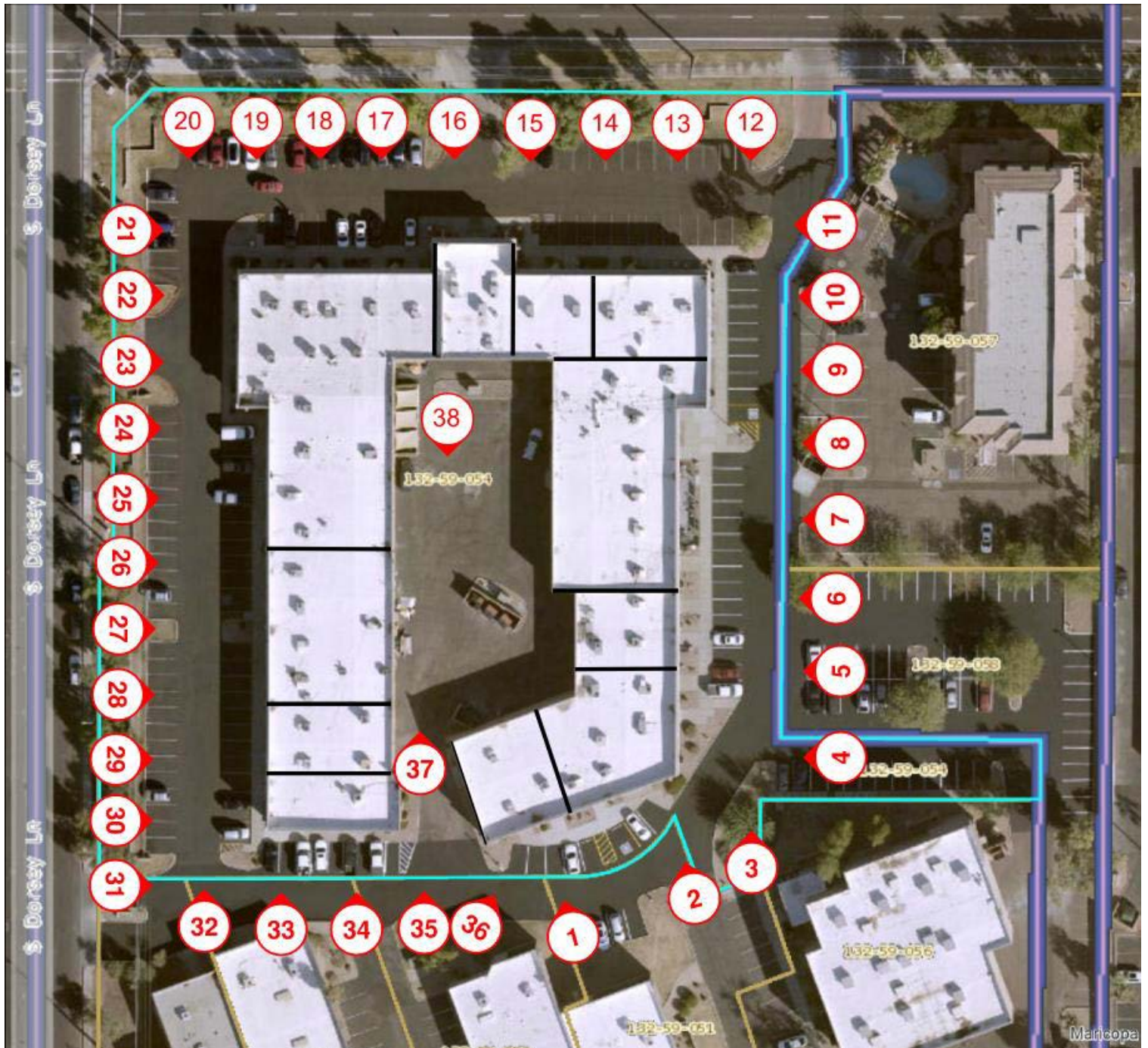

SITE CONTEXT PHOTOS



1. First photo starts at Suite 101. Subsequent photos walk around the building counterclockwise.



- 2.

937 W. Sherri Drive Gilbert, Arizona 85233 p. 480.235.7260
email: bryanmorris00@gmail.com



3.



4.

937 W. Sherri Drive Gilbert, Arizona 85233 p. 480.235.7260
email: bryanmorris00@gmail.com



5.



6.

937 W. Sherri Drive Gilbert, Arizona 85233 p. 480.235.7260
email: bryanmorris00@gmail.com



7.



8.

937 W. Sherri Drive Gilbert, Arizona 85233 p. 480.235.7260
email: bryanmorris00@gmail.com



9.



10.

937 W. Sherri Drive Gilbert, Arizona 85233 p. 480.235.7260
email: bryanmorris00@gmail.com



11.



12.

937 W. Sherri Drive Gilbert, Arizona 85233 p. 480.235.7260
email: bryanmorris00@gmail.com



13.



14.

937 W. Sherri Drive Gilbert, Arizona 85233 p. 480.235.7260
email: bryanmorris00@gmail.com



15.



16.

937 W. Sherri Drive Gilbert, Arizona 85233 p. 480.235.7260
email: bryanmorris00@gmail.com



17.



18.

937 W. Sherri Drive Gilbert, Arizona 85233 p. 480.235.7260
email: bryanmorris00@gmail.com



19.



20.

937 W. Sherri Drive Gilbert, Arizona 85233 p. 480.235.7260
email: bryanmorris00@gmail.com



21.



22.

937 W. Sherri Drive Gilbert, Arizona 85233 p. 480.235.7260
email: bryanmorris00@gmail.com



23.



24.

937 W. Sherri Drive Gilbert, Arizona 85233 p. 480.235.7260
email: bryanmorris00@gmail.com



25.



26.

937 W. Sherri Drive Gilbert, Arizona 85233 p. 480.235.7260
email: bryanmorris00@gmail.com



27.



28.

937 W. Sherri Drive Gilbert, Arizona 85233 p. 480.235.7260
email: bryanmorris00@gmail.com



29.



30.

937 W. Sherri Drive Gilbert, Arizona 85233 p. 480.235.7260
email: bryanmorris00@gmail.com



31.



32.

937 W. Sherri Drive Gilbert, Arizona 85233 p. 480.235.7260
email: bryanmorris00@gmail.com



33.



34.

937 W. Sherri Drive Gilbert, Arizona 85233 p. 480.235.7260
email: bryanmorris00@gmail.com



35.



36.

937 W. Sherri Drive Gilbert, Arizona 85233 p. 480.235.7260
email: bryanmorris00@gmail.com



37.



38.

937 W. Sherri Drive Gilbert, Arizona 85233 p. 480.235.7260
email: bryanmorris00@gmail.com