

**CITY OF TEMPE
DEVELOPMENT REVIEW COMMISSION**

**Meeting Date: 06/28/2022
Agenda Item: 8**

ACTION: Request a Use Permit for outdoor vending in the General Industrial District for DHL POPUP MOBILE SERVICEPOINT located at 1910 West Rio Salado Parkway. The applicant is DHL Express USA.

FISCAL IMPACT: There is no fiscal impact on City funds.

RECOMMENDATION: Approve, subject to conditions

BACKGROUND INFORMATION: DHL POPUP MOBILE SERVICEPOINT (PL220109) The request includes the following:

ZUP220024 Use Permit to allow outdoor vending in the General Industrial District.

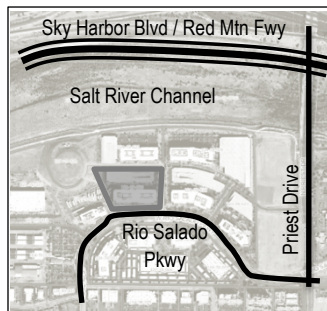

Existing Property Owner	Gail Lubin, representative of Liberty Property Limited Partners, lessee of City of Tempe property
Applicant	Essete Gebriel, DHL Express USA
Zoning District	GID
Gross / Net site area	9.5 acres
Total Building Area	158,326 s.f. (new mobile unit is 140 s.f.)
Lot Coverage	36% (NS in GID)
Building Height	44' PAD (35' maximum allowed in GID)
Building Setbacks	100' south front, 37' side, 29' rear (0, 0, 0', 10' min.)
Landscape area	46% (10% minimum required in GID)
Vehicle Parking	910 spaces (801 min. required) *mobile kiosk takes 3 parking spaces
Bicycle Parking	20 spaces (20 min. required)
Hours of Operation	10am-6pm M-F and 11am-3pm Saturday

ATTACHMENTS: Development Project File

STAFF CONTACT(S): Diana Kaminski, Senior Planner (480) 858-2391

Department Director: Jeff Tamulevich, Community Development Director
 Legal review by: N/A
 Prepared by: Diana Kaminski, Senior Planner
 Reviewed by: Steve Abrahamson, Principal Planner

COMMENTS:

This site is located on the north side of Rio Salado Parkway, west of Priest Drive, south of the Salt River Channel and east of the VORTAC airport navigation beacon. The site is designated as Industrial Use within the General Plan Projected Land Use Map. The proposed use meets the general plan objectives to encourage uses supporting businesses and residents within a 20-minute commute to reduce drive time for services. The site is located in Character Area Three, the Downtown Tempe/Rio Salado/ASU/NW Neighborhoods Character Area. The site is zoned General Industrial District (GID) and is located in the Rio Salado Overlay District. The site is part of the Second Amended Planned Area Development Overlay for Liberty Center at Rio Salado and is located on Lot 2 of the Liberty Center at Rio Salado Unit 3 Subdivision. Developed since 2015, the property is owned by the City of Tempe with a long-term lease agreement with Liberty Property Ltd. Partners who is managing the site with DHL Express USA as a tenant in the building proposing the additional mobile vending kiosk in the parking lot of their corporate headquarters. The proposed outdoor mobile vending unit complies with all requirements of the zoning code as it is not a permanent structure, it will be utilizing surplus parking on site. The increase in shipping has resulted in an increased demand for secure locations to deposit packages for delivery. The kiosk will help activate the area and provide services to residents within the larger community. Existing entitlements for this property that will remain in effect are the Planned Area Development Overlay and Development Plan Review for the site, landscape and building elevations, which are not impacted by this use permit. This request includes the following:

ZUP220024 Use Permit to allow outdoor vending in the General Industrial District.

The applicant is requesting the Development Review Commission act on the items above, there is no further processing required for this request.

SITE PLAN REVIEW

The application was reviewed and determined that it was not a Development Plan Review due to the proposed building being a mobile trailer on an axle. The use did require a use permit for outdoor vending, as the point of sale is in the kiosk, not inside the corporate headquarters. Staff requested more information on the use and dimensions of the trailer and inquired about a more permanent architectural solution inside the building. Although concern was expressed that the aesthetics of the mobile unit did not match the site and would function as advertising with signage that is not regulated by zoning code, the location was determined to not be detrimental in front of the tenant's corporate headquarters in an industrial park, with landscape at the street front.

PUBLIC INPUT

A neighborhood meeting not required.
No input received at completion of the report.

POLICE INPUT

There is no requirement for a security plan with this use. The applicant addressed questions regarding to security of the proposed use.

PROJECT ANALYSIS**USE PERMIT**

The proposed use requires a use permit, to operate an outdoor vending mobile unit within the GID zoning district. The applicant has provided a letter of explanation regarding the business operations.

Section 6-308 E Approval criteria for Use Permit (*in italics*):

1. *Any significant increase in vehicular or pedestrian traffic.* The proposed mobile package unit would remove up to three of the existing parking spaces within the parking lot, which are in excess of the required parking on site. The trailer would attract customers to the site for the purpose of package distribution, similar to a retail site. The site has approximately 100 spaces more than required by code, most of which are in a parking structure north of the office building. Aerial images of the front parking area over the past seven years indicate there are peak areas of heavy usage but do not appear to be entirely filled. According to the applicant's letter of explanation, it is anticipated there would be between 12-16 customers per day during business hours of 10am-6pm weekdays and 11am-3pm on Saturdays. The proposed use would not increase traffic beyond that anticipated by the current operations on site.

2. *Nuisance arising from the emission of odor, dust, gas, noise, vibration, smoke, heat or glare at a level exceeding that of ambient conditions.* The mobile unit is entirely self-contained with an exterior mounted HVAC unit screened from view. Lighting on the unit will comply with dark sky and crime prevention code requirements and not create glare in evening hours. The kiosk will have staff inside to interact with customers. As an industrial site, the proposed use is less intense than other allowed uses on site and will not exceed the ambient conditions of the corporate headquarters of DHL.
3. *Contribution to the deterioration of the neighborhood or to the downgrading of property values, the proposed use is not in conflict with the goals objectives or policies for rehabilitation, redevelopment or conservation as set forth in the city's adopted plans or General Plan.* The proposed kiosk will provide a safe, visible and fast location for surrounding businesses and nearby residents to process packaging for delivery within a short distance from the place of origin. The proximity to the airport and a significant employment hub makes this a compatible use for the location. The existing site infrastructure will not be changed, the nearest drop of point is more than 2 miles from this location in Phoenix; providing a location closer to Tempe residents and employees will reduce commute time and encourage reduced traffic within the city.
4. *Compatibility with existing surrounding structures and uses.* The existing corporate headquarters is proposing this mobile kiosk to serve customers. The design is a departure from the existing architecture on site but is not regulated by zoning code due to the temporary/mobile nature of the use, similar to a food truck or library kiosk.
5. *Adequate control of disruptive behavior both inside and outside the premises which may create a nuisance to the surrounding area or general public.* The kiosk is equipped with full security systems, cameras, and panic buttons. Cash is not accepted at these locations to help ensure employee safety. In addition to the kiosk security system, DHL has a 24/7 security team and security system for the whole building. The kiosk is also fully equipped with mobile IT.

The manner of conduct and the building for the proposed use will not be detrimental to persons residing or working in the vicinity, to adjacent property, to the neighborhood, or to the public welfare in general, and that the use will be in full conformity to any conditions, requirement or standards prescribed therefore by this code.

REASONS FOR APPROVAL:

1. The project meets the General Plan Projected Land Use for this site.
2. The project will meet the development standards required under the Zoning and Development Code.
3. The proposed project meets the approval criteria for a Use Permit.

Based on the information provided and the above analysis, staff recommends approval of the requested Use. This request meets the required criteria and will conform to the conditions.

USE PERMIT CONDITIONS OF APPROVAL:

EACH NUMBERED ITEM IS A CONDITION OF APPROVAL. THE DECISION-MAKING BODY MAY MODIFY, DELETE OR ADD TO THESE CONDITIONS.

1. This Use Permit for DHL POPUP MOBILE SERVICEPOINT is valid only after the required inspections have been completed and a Final Inspection has been passed.
2. The Use Permit is valid for the plans as submitted within this application. Any additions or modifications may be submitted for review during the building plan check process.
3. Hours of operation to end no later than 7 p.m. on a daily basis.
4. Except as modified by conditions, development shall be in substantial conformance with the plans submitted on June 3, 2022. Minor modifications may be reviewed through the plan check process of construction documents; major modifications will require submittal of a Development Plan Review.
5. The mobile unit shall be located in the three parking spaces designated on the site plan and shall not be moved to other parking spaces on site or placed in landscape.

6. Illuminate mobile unit building entrance with dark sky compliant fixtures from dusk to dawn to assist with visual surveillance of the area.
7. All prior conditions of approval for this site shall remain in effect.

CODE/ORDINANCE REQUIREMENTS:

THE BULLETED ITEMS REFER TO EXISTING CODE OR ORDINANCES THAT PLANNING STAFF OBSERVES ARE PERTINENT TO THIS CASE. THE BULLET ITEMS ARE INCLUDED TO ALERT THE DESIGN TEAM AND ASSIST IN OBTAINING A BUILDING PERMIT AND ARE NOT AN EXHAUSTIVE LIST.

USE PERMIT:

- The Use Permit is valid for DHL EXPRESS and may be transferable to successors in interest through an administrative review with the Community Development Director, or designee.
- The use permit approval shall be void if the use is not commenced or if an application for a building permit has not been submitted, whichever is applicable, within twelve (12) months after the use permit is granted or within the time stipulated by the decision-making body.
- The decision-making body, upon finding that the applicant has not taken corrective actions to resolve issues related to the permit/approval and that a continuation of the permit/approval is not in the interest of the public health, safety and general welfare, can revoke the permit/approval after providing written notice of its intentions to the holder of the permit.
- Any intensification or expansion of use shall require a new Use Permit.
- All required Federal, State, County, and Municipal permits, licenses, and clearances shall be obtained, or the Use Permit is void.

PARKING SPACES:

- Verify conformance of accessible vehicle parking to the Americans with Disabilities Act and the Code of Federal Regulations Implementing the Act. Refer to Building Safety ADA Accessible Parking Spaces Marking/Signage on Private Development details.
- At parking areas, provide demarcated accessible aisle for disabled parking.
- Distribute bike parking areas nearest to main entrance(s). Provide parking loop/rack per standard detail T-578. Provide 2'-0" by 6'-0" individual bicycle parking spaces. One loop may be used to separate two bike parking spaces. Provide clearance between bike spaces and adjacent walkway to allow bike maneuvering in and out of space without interfering with pedestrians, landscape materials or vehicles nearby.

ZONING AND DEVELOPMENT CODE:

- Specific requirements of the **Zoning and Development Code** (ZDC) are not listed as a condition of approval but will apply to any application. To avoid unnecessary review time and reduce the potential for multiple plan check submittals, become familiar with the ZDC. Access the ZDC through www.tempe.gov/zoning or purchase from Community Development.

LIGHTING:

- Design site security light in accordance with requirements of ZDC Part 4 Chapter 8 (Lighting) and ZDC Appendix E (Photometric Plan).
- Indicate the location of all exterior light fixtures on the site, landscape and photometric plans. Avoid conflicts between lights and trees or other site features in order to maintain illumination levels for exterior lighting.

SIGNS: Separate plan review process is required for signs in accordance with requirements of ZDC Part 4 Chapter 9 (Signs). Refer to www.tempe.gov/signs.

HISTORY & FACTS:

- February 14, 2013 City Council approved and entered into a Development Agreement with Liberty Property Limited Partnership.
- July 23, 2013 Development Review Commission approved the Development Plan Review and recommended approval of the Planned Area Development Overlay for LIBERTY CENTER AT RIO SALADO (PL130192) consisting of six (6) office buildings two-stories in height, and a future warehouse building. The request includes the following: (DPR13124) Development Plan Review for six (6) office buildings including site plan, building elevations, and landscape.
- July 30, 2013 City Council held the introduction and first public hearing for the Planned Area Development Overlay for LIBERTY CENTER AT RIO SALADO (PL130192) consisting of six (6) office buildings two-stories in height, and a future warehouse building. The request includes the following: (PAD13009) Planned Area Development Overlay for development standard modifications for maximum building heights from 35 feet up to 80 feet, and modified bicycle parking standards.
- August 22, 2013 City Council at the 2nd and final public hearing approved the Planned Area Development Overlay for LIBERTY CENTER AT RIO SALADO (PL130192) consisting of six (6) office buildings two-stories in height, and a future warehouse building. The request includes the following: (PAD13009) Planned Area Development Overlay for development standard modifications for maximum building heights from 35 feet up to 80 feet, and modified bicycle parking standards.
- October 24, 2013 City Council approved an Amended Subdivision Plat for LIBERTY CENTER AT RIO SALADO, consisting of 3 lots, located at 1850 West Rio Salado Parkway.
- The existing building was completed in 2015 and has had minor development plan review requests related to photovoltaic installation, parking structure, patio and shade amenities for employees.
- June 28, 2022 Development Review Commission is scheduled to hear the requested Use Permit for outdoor vending in the General Industrial District for DHL POPUP MOBILE SERVICEPOINT located at 1910 West Rio Salado Parkway.

ZONING AND DEVELOPMENT CODE REFERENCE:

- Section 3-302, Permitted Uses in Office/Industrial Districts
Section 6-308, Use Permit

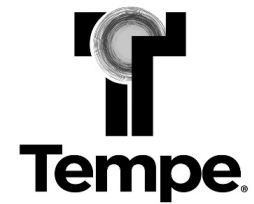

DEVELOPMENT PROJECT FILE

for
DHL MOBILE POPUP
(PL220109)

ATTACHMENTS:

1. Location Map
2. Aerial
3. Site Context Photos
4. Letter of Explanation for Use Permit
5. 2ND Amended PAD Site Plan (for reference)
- 6-7. Enlarged Site Plan and Dimensioned parking space placement plan
8. Mobile Pop Up Design Details (for reference)
9. Mobile Unit Floor Plan (for reference)
- 10-12. Elevations (for reference)
- 13-15. Mobile Unit placement in context to on site lighting (for reference)

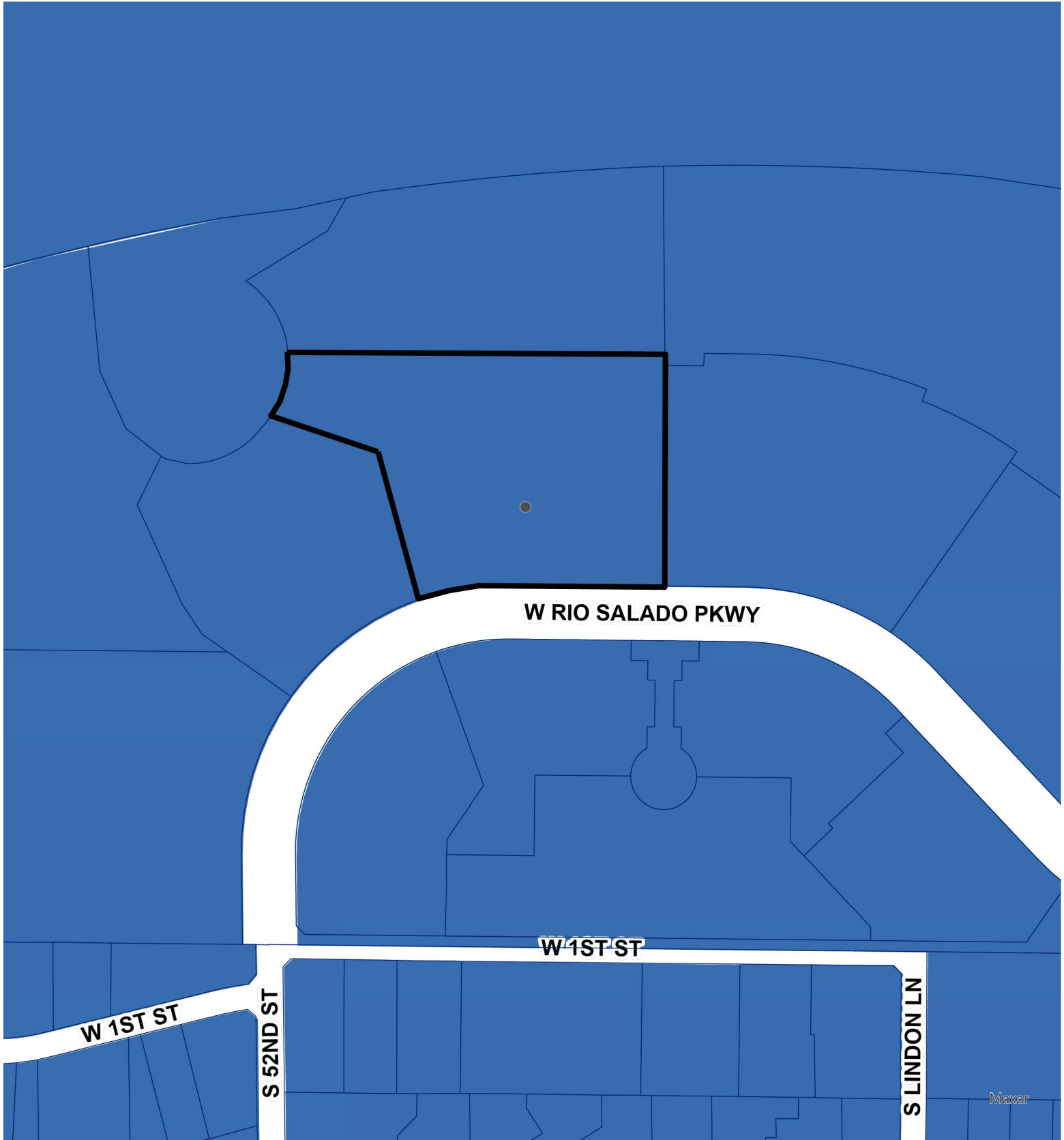

General Industrial District (GID)

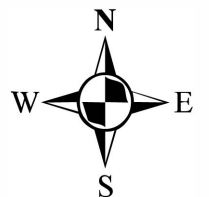



DHL Mobile Pop Up Unit



Aerial Map

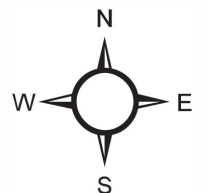



May 2nd 2022

City of Tempe

31 E 5th St.

Tempe, AZ

RE: Letter of Explanation

Dear Planning and Zoning team,

With the property owner City of Tempe Liberty Limited Partners' support, our company DHL Express US asks for your approval for Use Permit – outdoor retail vending permit to place a DHL Mobile Popup ServicePoint at DHL Express Corporate Office, on 1910 W Rio Salado Pkwy, Tempe, 85281.

We have been a proud member of the City of Tempe community for many years, and our Customer Relation Center for the US is based out of Tempe. We have always given local customers the option to ship at a designated counter at our stations and service points. The demand for our service increased by 50% during the pandemic. By placing our Mobile Popup ServicePoint within the designated parking spots at our corporate office, we can continue to support the residents, ASU students, and small businesses in the City of Tempe.

The Mobile Popup ServicePoint is a full-service shipping store built on a hydraulic lift platform and solar-powered to accommodate all essential amenities, such as HVAC, security, and computer systems – including a fast, efficient Point-of-Sale system that can process shipments for destinations around the US & the world. Hours of operations are from 10am – 6pm from Monday to Saturday.

We support the City's Sustainability Efforts and the City Character Areas Plan vision by providing an innovative, safe, unique, and sustainably powered retail store.

We have 14 of these popup stores operating across the US today in California, Texas, Virginia, Maryland, Ohio, and Florida. We have found these popup stores to positively impact surrounding businesses and properties and align with the city area policy plans. Therefore, we kindly ask for your approval to place the popup.

Enclosed in our request are the following documents:

1. ServicePoint Overview
2. Stamped architectural drawings of the structure

Thank you for your support and look forward to continuing to grow and evolve with the City of Tempe.

Sincerely,



Essete Gebriel Abebe
Sr. Retail Expansion Manager
DHL Express



West Side 4

North Side 3

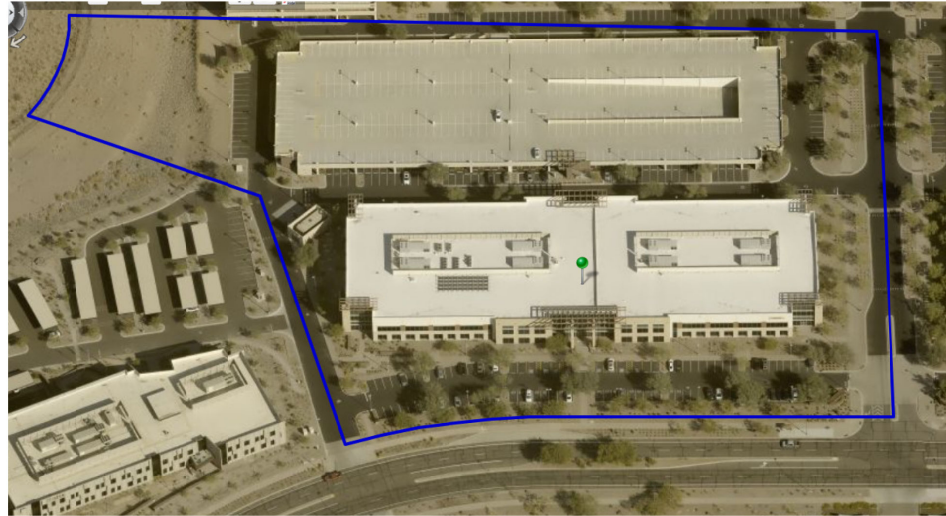

East Side 1

South Side 2



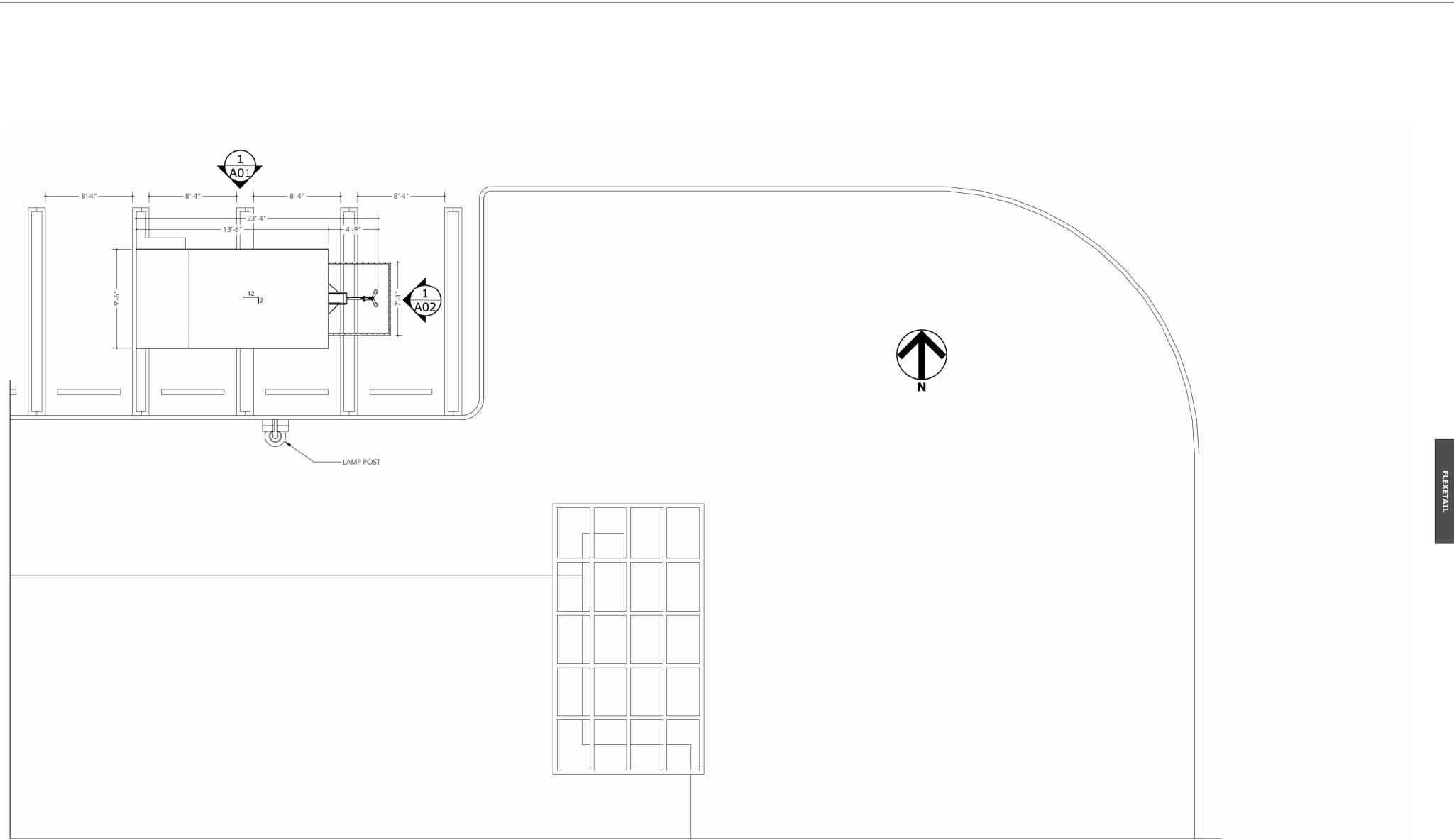

FLEXITAIL

1 PLAN
MS
Scale: 1/8" = 1'

Overview

**Location:**

Pop ups are positioned in well-lit shopping centers, in non-congested areas

**Structure:**

Steel-framed structure built on a hydraulic steel commercial trailer with ability to lower almost flush to the ground, 1” duo tempered glass with aluminum framing; stamped drawings provided

**Floor Plan:**

Floor plan of the trailers is approximately 140 square feet and has an interior usable space of 97 square feet

**Power:**

Off grid model uses solar/rechargeable batteries to power electronic equipment for business use and energy efficient mini-split HVAC.

**Accessibility:**

Wheel chair ramp available and personal concierge service provided as requested. *For Plantation, lobby service will also be available to accommodate customers as required

**Security:**

Includes fish eye camera, panic button, No cash. Security cabinet for all packages.



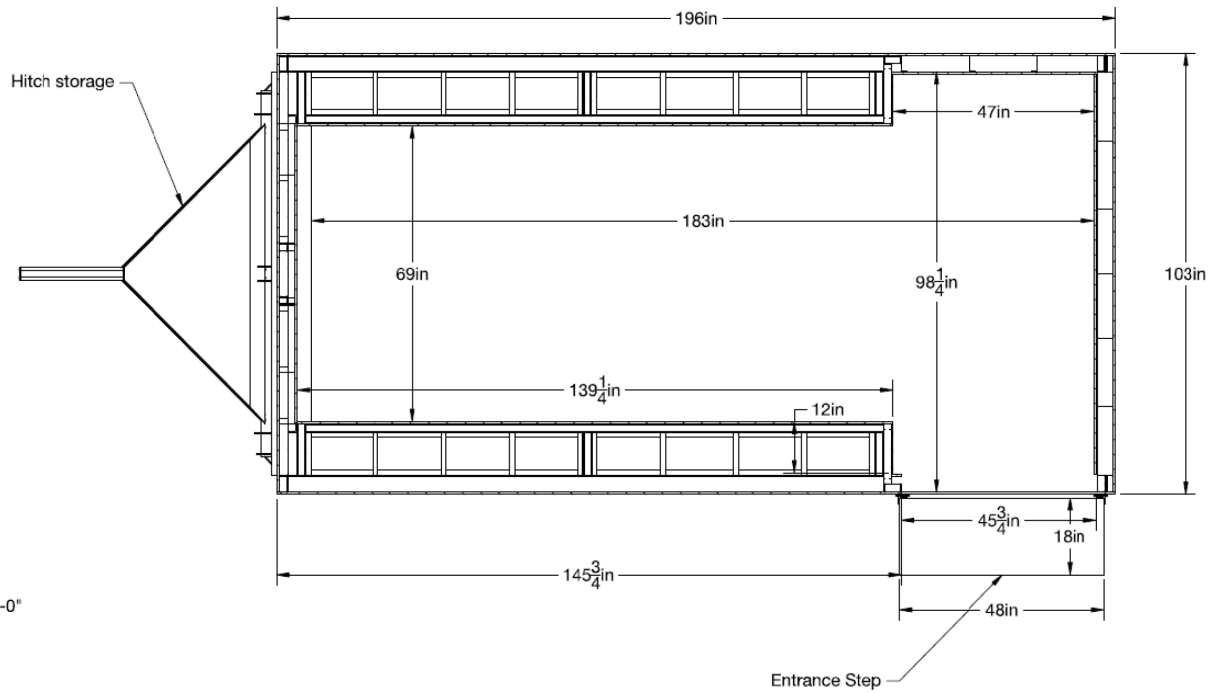
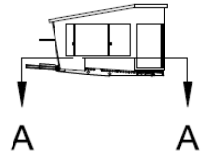

PLAN
 Scale: $\frac{1}{2}$ " = 1'-0"



DHL Mobile

Notes:

Scale 1/16" = 1'-0"

Structural Design

S101

Drawn By Aldar Syms
 No. © 2020 flexetail LLC

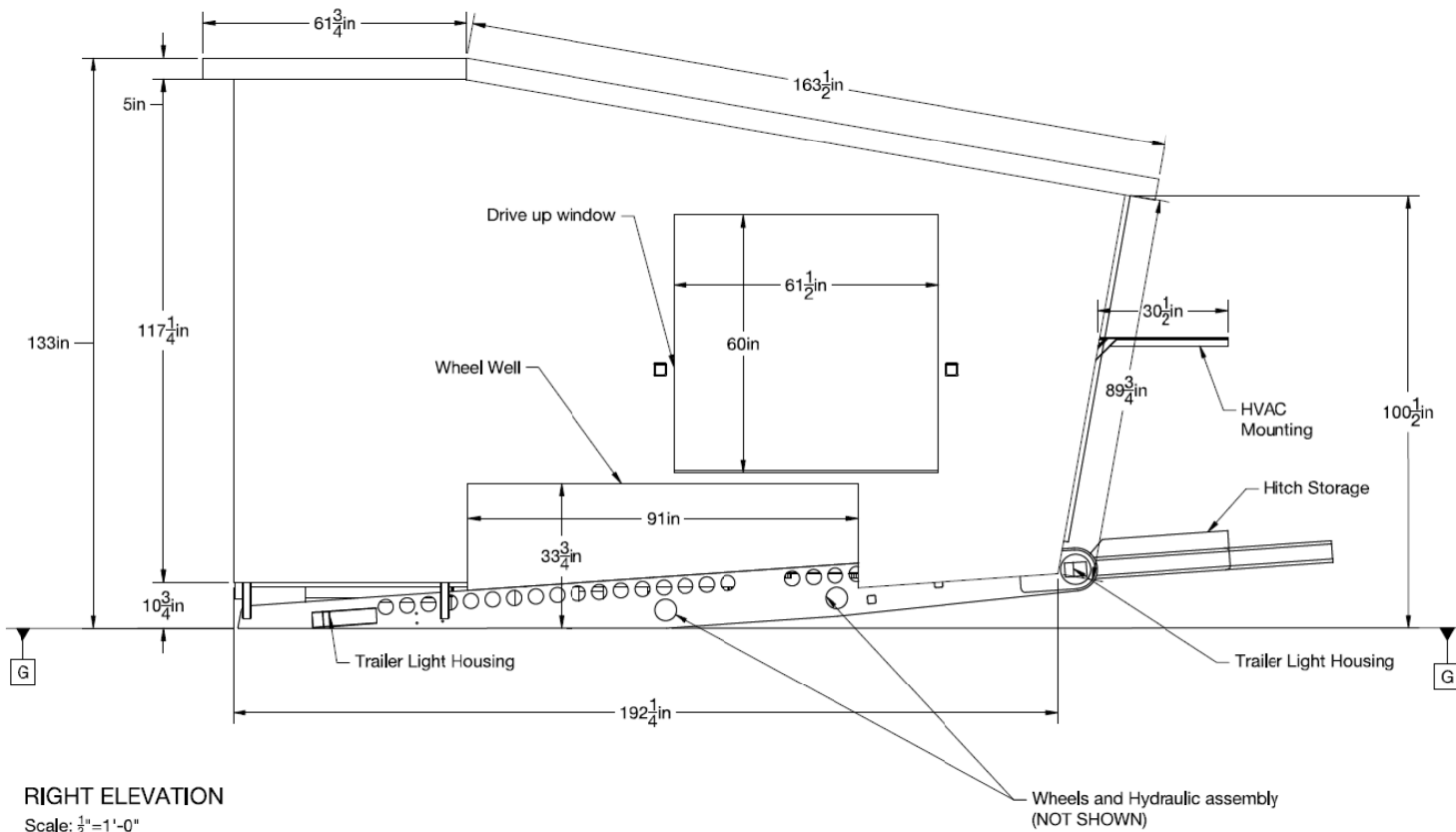

RIGHT ELEVATION
Scale: $\frac{1}{2}" = 1'-0"$



DHL Mobile

Notes:

Scale 1/2" = 1'-0"

Structural Design

S201

Drawn By Aican Syms
© 2020 flexetail LLC

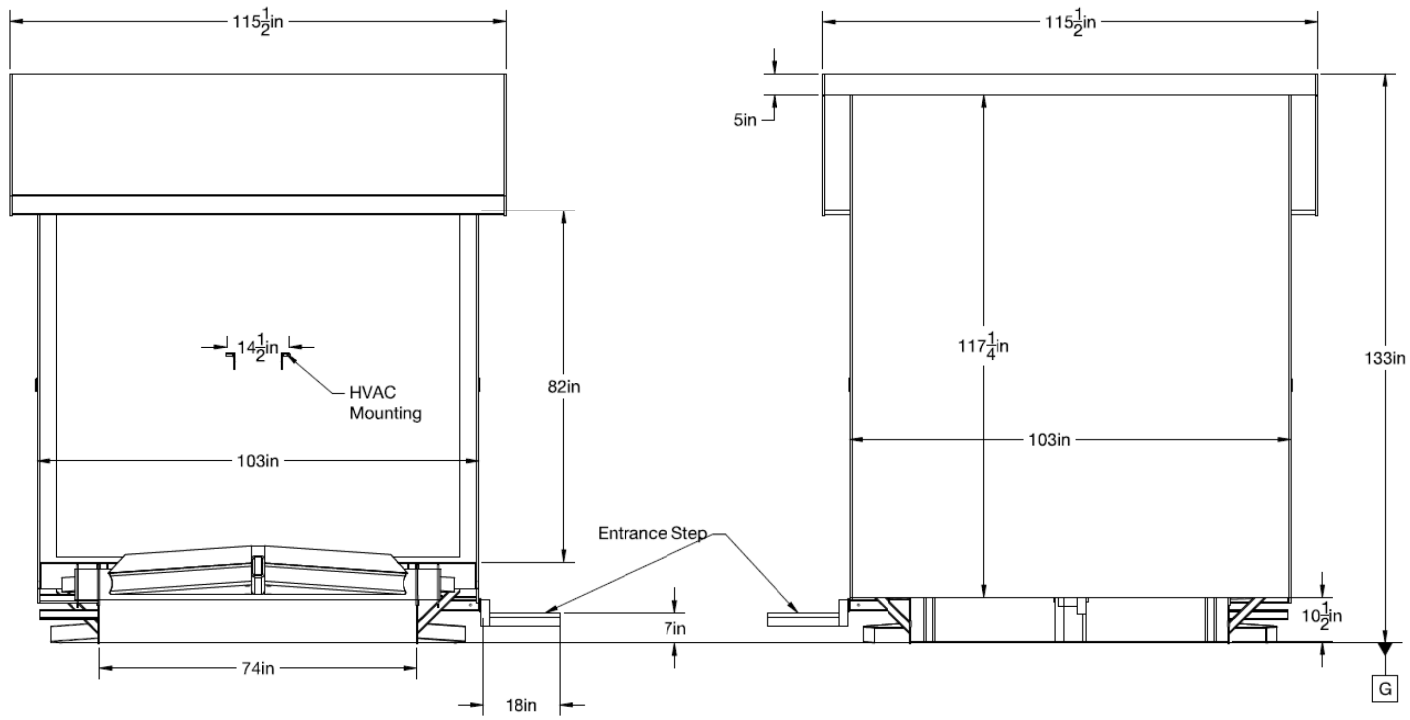

FRONT ELEVATION
Scale: 1/2" = 1'-0"

REAR ELEVATION
Scale: 1/2" = 1'-0"



DHL Mobile

Notes:

Scale 1/2" = 1'-0"
Structural Design

S203

Drawn By Aldar Syms
© 2020 flexetail LLC

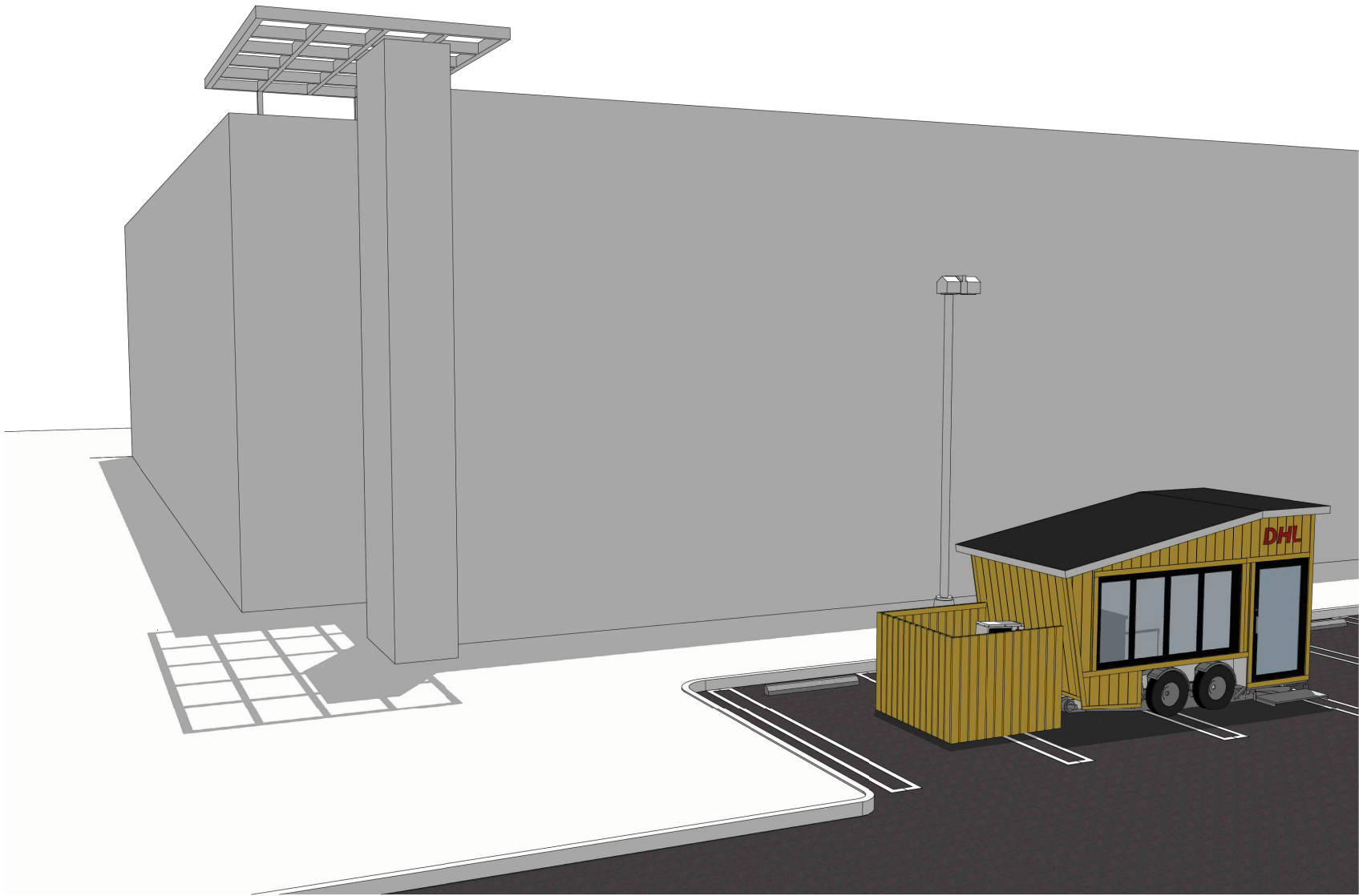

flexetail
YOUR SPACE ANYWHERE, ANYTIME

FLEXETAIL
40 Murphy Drive, Bay 7
Avon, MA 02322
617.905.2824
info@flexetail.com

DHL



